

Project _____

Item Number _____

Quantity _____

1000S



1000S Premium Slicer

Model:

➤ 1000S: 1/2hp Semi-Automatic Slicer



*NEW Low Friction Blade comes standard with slicer!

CERTIFIED BY NSF INTERNATIONAL TO MEET AND EXCEED THE NSF/ANSI 2012 STANDARDS

Premium Series Slicer

Features:

- Supermarket quality slicer
- Simple automatic control: 3 speed, 3 stroke length, and slice counter
- Unique drip tray fence redirects liquids away from controls and operator towards distinctive concave base casting for easy cleaning
- Ergonomic comfort design operation
- Powerful 1/2 hp motor standard
- Adjustable slice thickness from 0 to 7/8"
- Easily tilting carriage and removable sharpener for easy cleaning
- Quick and simple disassembly of carriage and feed grip for easy and thorough cleaning
- Sanitary polished and anodized aluminum construction
- Permanently mounted protective edge guard for operator safety
- Heavy duty 3-1/2 lb gravity fed grip
- Built in lift lever for under slicer cleaning
- Stationary knife guard and carriage

13" Precision slicing German hollow ground blade
Ultra Safe zero blade edge exposure while cleaning
Unique smooth curve transitions to redirect liquids away from controls and operator
Easily detachable carriage for easy cleaning

Univex Corporation

Optional Accessories:

- Stainless steel blade
- Stainless steel serrated blade
- Heavy duty clear plastic cover
- Stainless steel vegetable chute
- Sturdy stainless steel stand
- Security reinforced prison package

Warranty:

- One year, on-site parts and labor



WE RAISE THE BAR. WE SET THE STANDARD.

Premium Series Slicer

1000S

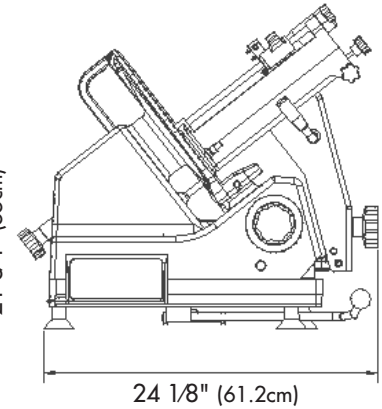
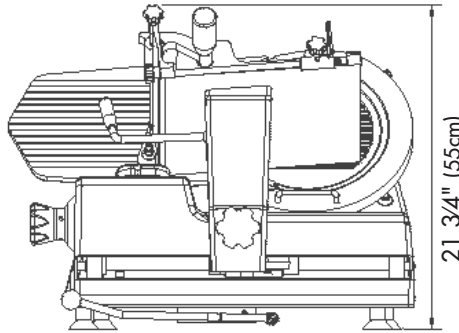
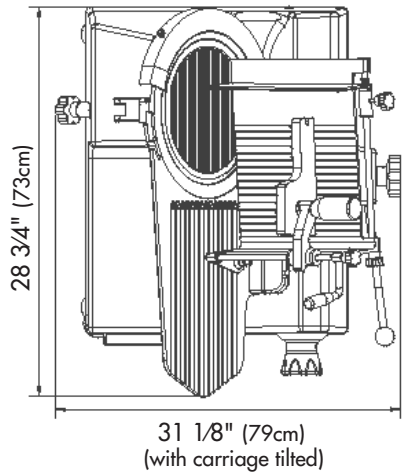

Controls: Manual slice thickness knob, digital membrane control for speed, stroke, and counter, removable blade sharpener

Drive Assembly: Belt driven

Blade diameter: 13" (33cm) razor sharp blade

Blade RPM: 337 RPM

Maximum slice thickness: .875" (2.2cm)

Maximum product size: Rectangular: 10.25" x 6" (26cm x 15.2cm)
Square: 6" x 6" (15.2cm x 15.2cm)
Round: 8" (20.3cm)

Construction: Anodized, cast aluminum body for durability and stunning looks

Nema #: 5-15-P

| Electrical Information (60Hz) | | | | | |
|-------------------------------|---------|-------|------|------|-----------|
| | Voltage | Phase | Amps | RPM | hp(kW) |
| Standard Voltage | 115 | 1 | 4.0 | 1680 | 1/2 (.37) |
| Optional Voltage | 208-240 | 1 | 2.5 | 1680 | 1/2 (.37) |

| Carriage Strokes | | | | |
|------------------|-----------------|--------------------|--------|------|
| | | Strokes per minute | | |
| | | Slow | Medium | Fast |
| Manual | 11.75" (29.8cm) | | | |
| Small | 4.25" (10.8cm) | 51 | 39 | 35 |
| Medium | 7.5" (19cm) | 59 | 44 | 42 |
| Large | 11" (28cm) | 64 | 50 | 52 |

| Shipping Information | | |
|----------------------|------------------|--|
| Net Weight | Shipping Weight | Overall Shipping Dimensions |
| 153lbs. (69.4Kg) | 163lbs. (73.9Kg) | 29" (73.9cm) H x 25" (64.5cm) W x 30" (74.9cm) D |



Univex Corporation
www.Univexcorp.com

3 Old Rockingham Rd
Salem, NH 03079
United States of America

TEL: (800)258-6358
INTL TEL: (603)893-6191
FAX: (800)356-5614
INTL FAX: (603)893-1249