



Manufacturer and Supplier of
Restaurant Equipment
 and **Display Cases**
 for the Food Service Industry



MODEL: SC-72-DRT

PRODUCT FEATURES

DOUGH RETARDER

- Super structure to hold (4) 1/6 pans
- Stainless Steel front
- 2 1/2 pull out Stainless Steel doors
- Self-contained
- 32" marble top
- Holds 33°-41°F temperatures
- Compressor can be serviced easily
- Environmentally friendly 134A refrigerant
- Full size doors designed to store dough pans
- Tray slides (optional)

- | | |
|-------------------|-------------------------|
| Casters | 5" Casters Optional |
| Warranty | 1 yr Parts & Compressor |
| Front Door | Stainless Steel |
| Front Motor Cover | Anodized Aluminum |
| Interior Walls | Stainless Steel |
| Outside Back | Galvanized |

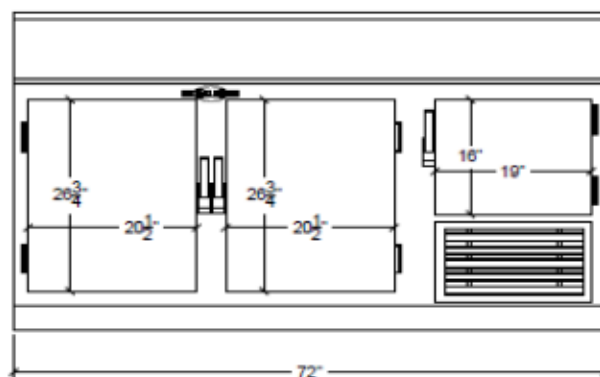
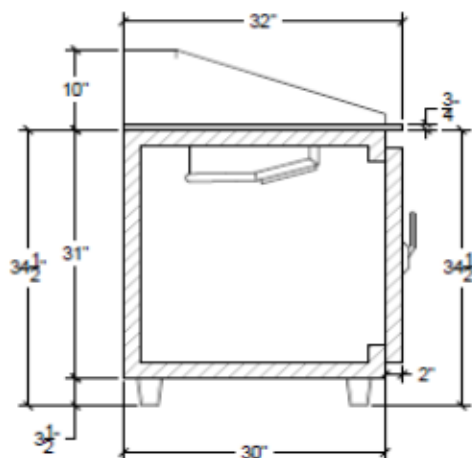

Product Specifications

Dimensions	Doors	Pans	Cooling Cycle	Refrigerant	HP	Power	Ampr.	BTU	Freon (oz)
72" x 32" x 46"	2 1/2	4	33-41	134a	1/3	115/60/1	12.5	1400	11.5

Additional Models

Model #	Doors	Pans	Cooling Cycle	Refrigerant	HP	Power	Ampr.	BTU	Freon (oz)
SC-48-DRT	1 1/2	4	33-41	134a	1/3	115/60/1	9.8	1100	10
SC-96-DRT	3 1/2	12	33-41	134a	1/2	115/60/1	14	1850	15

* Model number designates product length. Due to product improvement, we reserve the right to change specifications without notice.