



Manufacturer and Supplier of
Restaurant Equipment
 and **Display Cases**
 for the Food Service Industry



MODEL: SC-48-BM

PRODUCT FEATURES

- Mega Top Sandwich Prep station
- 8" plastic cutting board
- Stainless Steel front
- 1 1/2 pull out Stainless Steel doors
- Self-contained
- Fits (3) standard hotel size pans
- Interior lighting
- Holds 33°-41°F temperatures
- Compressor can be serviced easily
- Environmentally friendly 134A refrigerant
- 1/4 HP, 115V, 7.5 Amps

CUSTOM SIZES AVAILABLE

- | | |
|-------------------|-------------------------|
| Casters | 5" Casters Optional |
| Warranty | 1 yr Parts & Compressor |
| Front Door | Stainless Steel |
| Front Motor Cover | Anodized Aluminum |
| Interior Walls | Stainless Steel |
| Outside Back | Galvanized |

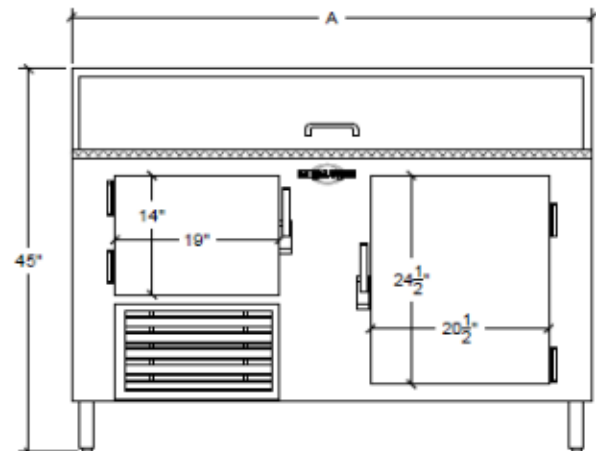
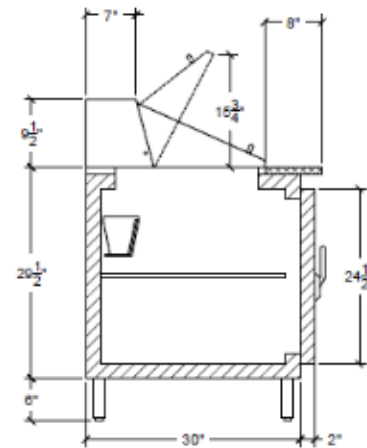

Product Specifications

Dimensions	Doors	Shelves	Pans	Refrigerant	HP	Power	Ampr.	BTU	Freon (oz)
48" x 32" x 45"	1 1/2	1	18	134a	1/3	115/60/1	7.5	900	11.5

Additional Models

Model #	Doors	Shelves	Pans	Refrigerant	HP	Power	Ampr.	BTU	Freon (oz)
SC-27-BM	1	1	12	134a	1/4	115/60/1	8	850	10
SC-60-BM	1 1/2	1	24	134a	1/3	115/60/1	8.5	900	11.5
SC-72-BM	2 1/2	2	30	134a	1/3	115/60/1	9	1150	11.5

* Model number designates product length. Due to product improvement, we reserve the right to change specifications without notice.