

USER MANUAL

COUNTERTOP DISPLAY REFRIGERATED MERCHANTISER



MODEL: U-CF2



USR Brands, Inc.

Phone: 800-764-1172 | www.usrestaurant.com | sales@usrestaurant.com

1. Structural diagram

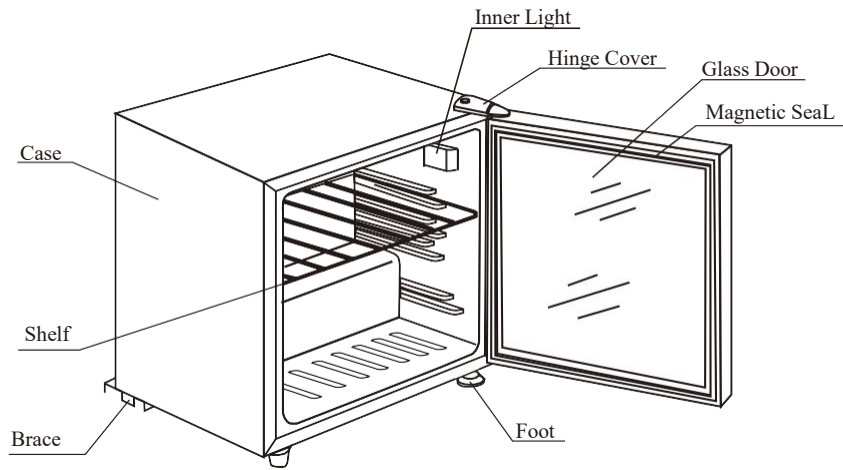

Problems	Possible cause	Ways to solve problems
Too high noise	The unit is not level	Adjust the adjustable legs
	The fastener of the unit is loose	Fasten the loose fastener
	Pipes are touching the compressor	Careful separate the touched pipes
Light is not on	The light is burned out	Replace the light

Caution: Dismantling the unit by non-professional staff is prohibited, it will cause hazard.

2. Specifications

Model	U-CF2
Climatic class	N
Storage Temperature (°F)	-13 ~ 5
Anti-shock protection class	I
Net Volume	2 cu. ft
Rated Voltage (V)	115V
Rated Frequency (Hz)	60Hz
LAMP max power(W)	10
Refrigerant/Charging (g)	R290

The above specifications are subject to improvements.

Problems	Possible cause	Ways to solve problems
Abnormal operation of the compressor or has buzz sound	The power voltage is out of the rated range.	Disconnect the power supply immediately and reconnect with it after normal voltage. It is necessary to have a voltage stabilizer in case of poor power supply.
Compressor operates too long time and no frost on the surface of inner cabinet	Refrigeration system is at fault (leakage or blocked)	Send the unit to service department for repair
There is frost or ice on the walls of the inner cabinet and too low internal temperature, the compressor operates never stop	Thermostat does not work	Ask service department for repair
The internal temperature is too high and the compressor operates never stop	Bad heat dissipation and ventilation of casing, the ambient temperature is too high	Improve ventilation and lower the ambient temperature.
	Too much warm food was put in at one time	Take out some food
	Door open frequently and long time door opening	Decrease number and time of door opening.

3. Safety Cautions

- 1) This unit uses AC115V/60Hz power, there should be a 500va stabilizer if the voltage fluctuation exceed AC99V~132V
- 2) The user should hold the plug when the power is on/off, dragging or pulling the power cord is prohibited.
- 3) Do not remove the power cord or plug
- 4) Must use dependent socket and reliable ground wire. Ground wire must not connect with the null line of the gas pipe, warm gas pipe, water pipe and must be single power
- 5) Never splash water on the unit directly.
- 6) Keep away from explosive, hazardous goods such as ether, gas, alcohol, bonding agents, gunpowder etc.
- 7) Keep away from spray of inflammables such as paints, coating materials etc.
- 8) After the unit is switched off, it should not be restarted within 5 minutes.
- 9) Do not leave the power cord under any heavy objects including the unit itself.
- 10) Do not drill holes or install other objects on the casing.
- 11) This cooler is not suitable for storage pharmaceutical products.

4. Portage and storage

- 1) Keep the unit vertical when carrying the unit, the angle to the horizontal line should not be over 50°, otherwise it will damage the compressor and affect normal operation of the unit.
- 2) The unit should be placed on a solid and firm ground, take away the bottom pack to lower the shock and noise.
- 3) Leave at least 20 cm of distance between the back of the unit and the wall for ventilation and leave a space with an open angle of 160° for the door.
- 4) Keep the unit away from heat sources and avoiding direct sunlight.
- 5) Never place the unit on a location where water can reach or with high moisture. Splashed water and dirt should be wiped off in time by using a soft cloth.
- 6) Do not place the unit in the environment cold enough to be iced.

5. Preparation

- 1) Remove the carton and packing foam (including the bottom foam) before using.
- 2) Clean the unit before using.
- 3) Adjust the foot to make the unit steady according to the ground condition to lower the shock and noise.

- 4) After moving the unit, place the unit for 30 minutes before switching it on. Running: close the door and connect the power, turn on the lamp switch on the control panel, the lamp is on. Half an hour later, the temperature inside the case lower apparently, it indicates the unit on be normally used
- 5) After connecting the power, the unit should be kept empty for one hour.

6. Setting and adjustment of temperature

- 1) Adjust the storage temperature through the temperature controller located on the back of the case(see the picture), adjust the temperature according to the ambient temperature and the foodstuff.
- 2) Using the CNC thermostat to adjust the temperature. ↑ Up arrow adjusts the temperature rising inside the cooler. ↓ Down arrow adjusts the temperature dropping inside the cooler. Digital display shows current temperature inside the cooler! Press shutdown key for 6 seconds to turn off the system.
- 3) Please refer to the CNC thermostat instructions in detail.

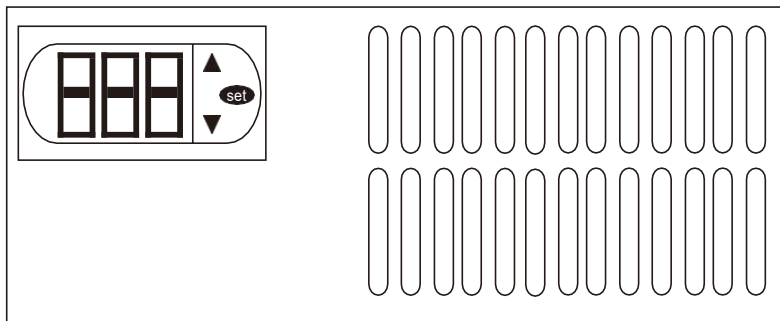

7. Storage of articles

- 1) Do not put large amount of articles into the unit at one time, you should leave some space around the foodstuff to let cold air inside the cabinet counter to flow. Keep bottled articles away from the walls of interior cabinet so as not to freeze it until broken.
- 2) Do not put warm food into the unit directly until they are cooled under normal temperature, it will facilitate to lower its energy consumption and prolong service life of the compressor.

8. Maintenance

Disconnect the power supply before maintenance for the machine!

- 6) Keep the door gasket clean, remove it from the door and wash it. Dry and seal it as before. Putting some talcum powder on the magnetic surface would prolong its service life.
- 7) Bulb replacement: remove the lamp shade, take out the bulb, replace with a new bulb, then mount it again.
- 8) If there is heavy frost on the evaporator after long usage, take out the stuff inside the case, disconnect the power, the frost will melt automatically, clean up the water and connect the power again.
- 9) Use a soft cloth and dip some water or soap (Non-caustic, neutral detergent is also available) to clean the unit. Dry the unit after cleaning to avoid rust.
- 10) Do not use organic liquid, boiled water, washing powder or acid stuff to clean the unit. Rinsing the case by water is not allowed, don't use hard brush, steel brush to clean the case.
- 11) If the unit will not be used for a long time, disconnect the power, clean it by following the above steps, wipe off the water inside the case with a soft cloth.

9. Caution

- 1) The unit is not suitable for storage of blood, pharmaceutical products and biological products
- 2) Do not place heavy articles on the top of the unit.
- 3) In case of trouble, please ask professional person for service, do not dismantle the unit without prior authority to avoid hazard.

10. Normal Phenomena

- 1) Sometime hear light sound of water flowing in the unit, this is the sound of refrigerant flowing inside the pipe.
- 2) the top ,and the two sides of the casing will be warm, even too hot.
- 3) In a humidity place, there is dew on the casing or the door, it can dry by dry cloth.

11. Troubleshooting guide

Problems	Possible cause	Ways to solve problems
The units does not work	Bad connection of plug	re-connect the plug to power supply