

REFRIGERATOR MANUFACTURER
Turbo air
 more durable, efficient, beautiful

4184 E. Conant St.
 Long Beach, CA 90808
 Tel. 310-900-1000
 Fax. 310-900-1077
www.turboairinc.com

Project:	
Model #:	
Item #:	
Available W/H:	Qty:
Approval:	
AIA #:	SIS #:
CSI Section 11400	

Horizontal Open Display Cases

Low Profile
 Solid Side Panel

Patented Self-Cleaning Condenser



This product is equipped with a fine mesh filter to the front of the condenser to catch dust, and a rotating brush that moves up and down daily to remove excess buildup outward and away.

Model : TOM-30LB-SP(-A)-N



TOMD-LB

Top display dry case available (optional)



TOM-30LB-SP-N



TOM-30LB-SP-A-N

FEATURES & BENEFITS

Self-Cleaning Condenser

The accumulation of dust in the condenser can cause the failure or breakdown of refrigerators. Refrigerators run normally until they reach a certain level of accumulation. At some point, when they are over the limit, their performance drops quickly resulting in damage to, or disposal of the stored products inside. The Self-Cleaning Condenser device keeps the condenser clean and prevents system failure by automatically brushing daily.

Hydrocarbon refrigerants (R-290)

With innovative and eco-friendly technology, Turbo Air brings you hydrocarbon refrigerators designed to meet DOE's Energy Conservation Standards in 2017 and to use EPA's SNAP Program approved HC refrigerants. Hydrocarbon refrigerants do not deplete the ozone layer and have very low contribution to global warming (ODP-0, GWP-3).

Modern design

By integrating great contours with durable structures, our modern style product designs are user-friendly while maintaining the highest product visibility and aesthetics. Safety reinforced tempered glass front shield optimizes the merchandiser's display effects of fresh salads, sandwiches, desserts and beverages. Its elegant contemporary euro design will enhance any store application. Ideal for eye-catching displays and convenient access with fast service in high traffic areas.

LED interior lighting under each shelf

Interior materials available in two standards

SP: stainless steel interior for sanitary purposes
 SP-A: black coated interior with mirrored sides for maximized display effects.

Solid side panels used to ensure durability

Standard back-guard improves airflow

Perforated interior back wall & top for improved air flow

Foamed with polyurethane, high-density cell insulation (CFC free)

Front air intake and rear air discharge



Model	CU./FT.	# of Shelves	HP	AMPS	Crated Weight (lbs.)	L x D x H† (inches)
TOM-30LB-SP(-A)-N	5.1	1	1/3	6.7	340	28 x 33 1/2 x 45 7/8

Horizontal Open Display Cases

Low Profile
Solid Side Panel

Model : TOM-30LB-SP(A)-N

ELECTRICAL DATA	
Voltage	115/60/1
Plug Type	 NEMA 5-15P
Full Load Amperes	6.7
Compressor HP	1/3
Cord Length (ft.)	47/8
Refrigerant	R-290
DIMENSIONAL DATA	
Net Capacity (cu. ft.)	5.1
Ext. Dimension (L x D [†] x H [†]) (in.)	28 x 33 1/2 x 45 7/8
Int. Dimension (L x D x H) (in.)	25 5/8 x 24 x 17 1/2
# of Shelves	1
Shelf Size (L x D) (in.)	25 1/2 x 10 3/4
Net Weight (lbs.)	257
Gross Weight (lbs.)	340

Design and specifications subject to change without notice.
Actual shipping weight may differ due to extra packing materials for product protection.
* Depth does not include 1-1/4" for rear spacers.
† Height does not include 5/8" for bolt height.

■ WARRANTY : 2 Year Parts and Labor Warranty Additional 3 Year Warranty on Compressor

■ STANDARD FEATURES

- Simple plug-in installation
- Patented self-contained system, no plumbing required
- Solar powered digital thermometer
- Digital electronic thermostat with defrost control
- Bolt height adjustable up to 2-3/4"
- Standard color comes in black only

**Lead time applies. Please contact your sales representative for more details to order.

■ Recommended operating conditions

TOM models are designed to operate in an environment where temperature & humidity do not exceed 80°F and 55% respectively. Units should not be installed near HVAC vents, fans or doorways that will disrupt the air curtain and compromise the function of the cabinet. Air curtain models will run most efficiently when completely loaded with product. When used as a built-in, required clearance for the rear is 4" and the top is 5".

■ OPTIONAL ACCESSORIES

- 1.6" caster: CAS16WBT00 (non-brake)
- 4" caster, 1/2" diameter & 13 TPI: G8F6500101 (non-brake), G8F6500201 (w/ brake)
- 6" leveling seismic leg (1/2", 13 TPI): 30221M0700
- Top display dry cases: TOMD-30LW(B) (Low), TOMD-30HW(B) (High)
- Night cover: NCT-30-W (White), NCT-30-B (Black)
* Night cover can not be used in conjunction with a TOMD dry case.
- Security cover: SCW-30LB
- Price tag channel: P3000000ZK (25 1/2"L)

Ver.20210804

PLAN VIEW

(unit : inch)

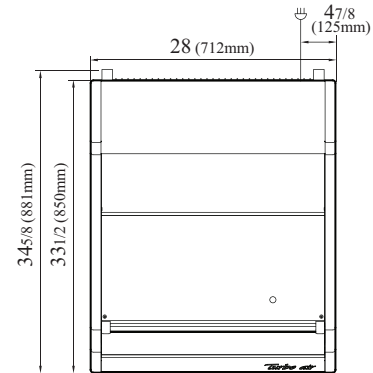

TOP VIEW

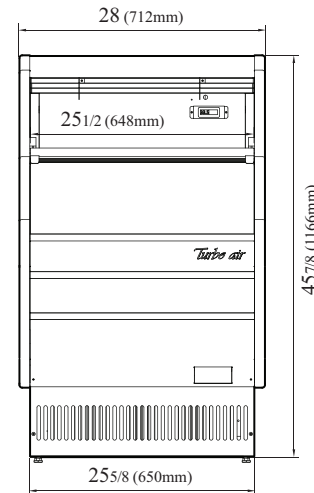

FRONT VIEW

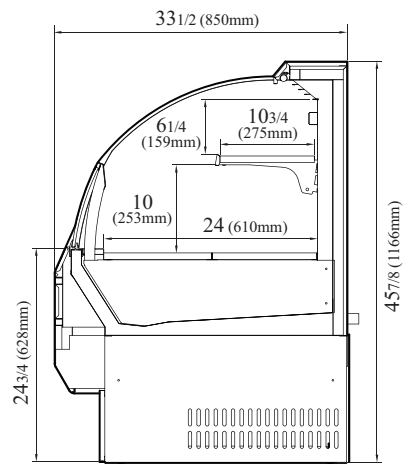

SIDE VIEW



- Turbo Air : 800-627-0032
- GK : 800-500-3519
- Warranty : 800-381-7770
- AC : 888-900-1002

REFRIGERATOR MANUFACTURER
Turbo air

GERMAN
KNIFE

RADIANCE

REFRIGERATION SYSTEM
Turbo air

Texaking

Continued product development may necessitate specification changes without notice.