



PROJECT NAME		LOCATION		AIA #
ITEM #	QTY	MODEL #		SIS #

SPEC SERIES®

REACH-IN SOLID SWING DOOR FREEZERS

models	STR3F-3S	STA3F-3S	STG3F-3S
--------	----------	----------	----------



STR3F-3S	
Exterior	Stainless steel door, front & sides.
Interior	Stainless steel side walls, back, floor, door liner, & ceiling.
Shelving	(1) Interior kit option included per full section.

STA3F-3S	
Exterior	Stainless steel door, front & sides.
Interior	Aluminum side walls & back. Stainless steel floor & ceiling.
Shelving	(3) Heavy duty, chrome plated, wire shelves per section.

STG3F-3S	
Exterior	Stainless steel door, with matching aluminum sides.
Interior	Aluminum side walls & back. Stainless steel floor & ceiling.
Shelving	(3) Heavy duty, PVC coated, wire shelves per section.

plan view

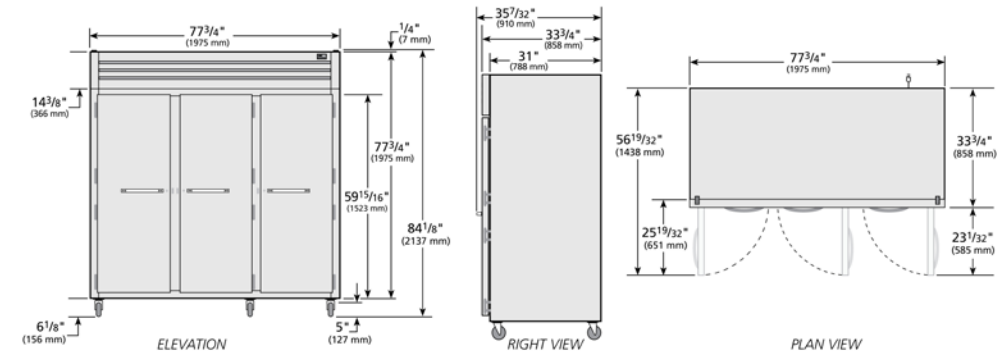

SPECIFICATIONS

Dimensions	in.	mm.
Length	77 3/4	1975
Depth	33 3/4	858
Height	77 3/4	1975
Electrical	U.S.	International
Horsepower	2 3/4	N/A
Amps	8.3	N/A
Voltage	208/230/60	
NEMA	6-15P	
Cord Length	9 ft.	2.74 M.

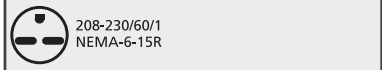

* Height does not include 6 1/8" (156 mm) for castors or 6" (153 mm) for optional legs.
 † Depth does not include 1 1/2" for door handle.

Specifications subject to change without notice.
 Chart dimensions are rounded up to the nearest 1/8" (millimeters rounded up to the next whole number).

	APPROVALS	AVAILABLE AT
4/15	Printed in U.S.A.	



PROJECT NAME	LOCATION	AIA #
ITEM #	QTY	MODEL #
		SIS #

SPEC SERIES®

REACH-IN SOLID SWING DOOR FREEZERS

models	STR3F-3S	STA3F-3S	STG3F-3S
--------	----------	----------	----------



standard features

REFRIGERATION SYSTEM

- Factory engineered, self-contained, capillary tube system using environmentally friendly (CFC free) R404A refrigerant.
- High capacity, factory balanced refrigeration system that maintains -10°F (-23.3°C) temperatures. Ideal for both frozen foods and ice cream.
- State of the art, electronically commutated evaporator and condenser fan motors. ECM motors operate at higher peak efficiencies and move a more consistent volume of air which produces less heat, reduces energy consumption and provides greater motor reliability.
- Top mounted refrigeration system with evaporator positioned out of food zone.
- Automatic defrost system time-initiated, temperature-terminated. Saves energy consumption and provides shortest possible defrost cycle.
- Automatic evaporator fan motor delay during defrost cycle.

CABINET CONSTRUCTION

- Insulation - entire cabinet structure and solid door are foamed-in-place using Ecomate. A high density, polyurethane insulation that has zero ozone depletion potential (ODP) and zero global warming potential (GWP).
- 5" (127 mm) diameter plate castors - locks provided on front set.

DOORS

- Lifetime guaranteed bolt style door locks.
- Lifetime guaranteed heavy duty all metal working door handles.
- Positive seal self-closing doors with 120° stay open feature. Lifetime guaranteed external cam lift door hinges, four (4) per door section.
- Magnetic door gaskets of one piece construction, removable without tools for ease of cleaning.

LIGHTING

- LED interior lighting, safety shielded.

MODEL FEATURES

- Exterior digital temperature display, available with either °F or °C.
- Evaporator epoxy coated to eliminate the potential of corrosion.
- Curb mounting ready.
- NSF-7 compliant for open food product.

ELECTRICAL

- Unit completely pre-wired at factory and ready for final connection to a 208-230V / 60 Hz single phase, 15 amp dedicated outlet. Cord and plug set included.

OPTIONAL FEATURES/ ACCESSORIES

(upcharge & lead times may apply)

- 6" (153 mm) standard legs.
- 6" (153 mm) seismic/flanged legs.
- 6" (153 mm) stainless steel legs.
- Field reversible hinge.
- Additional shelves.
- Stainless back. (STR, STA, STG)

SHELVING KIT OPTIONS

- STR series kits factory installed at no charge. STA & STG series kits field installed, upcharge applies, lead times may apply.
- Kit #1: Nine (9) sets of #1 type tray slides and pilasters (field installed), bottom support of one (1) 18"L x 26"D (458 mm x 661 mm) pan or two (2) 14"L x 18"D (356 mm x 458 mm) pans.
- Kit #2: One (1) set half-section #2 steel rod tray slides and pilasters (field installed), rim support of one (1) 18"L x 26"D (458 mm x 661 mm) pan.
- Kit #3: Six (6) sets of universal type tray slides and pilasters (field installed), bottom support of one (1) 18"L x 26"D (458 mm x 661 mm) pan, two (2) 14"L x 18"D (356 mm x 458 mm) pans or two (2) 12"L x 20"D (305 mm x 508 mm) pans.
- Kit #4: Three (3) chrome shelves 25"L x 27 3/4"D (635 mm x 705 mm). Optional wall mounted shelf support pilasters (field installed) with four (4) shelf clips per shelf available; adjustable on 1/2" (13 mm) increments (must order at time of cabinet order).
- Additional kit option components available individually.

WARRANTY*

Three year warranty on all parts and labor and an additional 2 year warranty on compressor. (U.S.A. only)

METRIC DIMENSIONS ROUNDED UP TO THE NEAREST WHOLE MILLIMETER

SPECIFICATIONS SUBJECT TO CHANGE WITHOUT NOTICE



Model	Elevation	Right	Plan	3D	Back
ST()3F-3S					

*RESIDENTIAL APPLICATIONS: TRUE assumes no liability for parts or labor coverage for component failure or other damages resulting from installation in non-commercial or residential applications.