

| | |
|----------|-----------|
| Project: | Quantity: |
| Model #: | Approval: |

For Commercial Use Only

SR-SM36 36" Gas Salamander Infra-Red Broiler - 35,000 BTU



FEATURES

- Stainless Steel front and Sides
- 35,000 BTU Infra-red burner
- Standing pilot igniton system
- Full width broiler pan
- 3/4" rear gas connection with regulator
- 3 Position Adjustable spring balancedrack
- Ball grip handle on adjustable rack forease and comfort
- LP gas conversion kit included
- Ready to mount over any Standard Range 36-60" range
- 4" adjustable height, non-skid SS Legs included for countertop operation

- CSA
- cCSAus
- CSA Sanitation



USR Brands Group is a US supplier of premium quality commercial cooking, refrigeration and food preparation equipment. Our aim is simple. Produce industry-leading commercial restaurant equipment at reasonable prices, and back it all up with an easy to understand, no nonsense warranty that people can count on.

| | |
|----------|-----------|
| Project: | Quantity: |
| Model #: | Approval: |

For Commercial Use Only

TECHNICAL DATA

DIMENSIONS

| | |
|-------------------------|----------------------|
| Exterior Dimensions | 36"L x 24.7"D x 18"H |
| Packaging Dimensions | 39"L x 27"D x 24"H |
| Cooking Area Dimensions | 27.5"L x 12.6"D |
| Unit Weight | 128 lb. |
| Shipping Weight | 186 lb. |

COOKING

| | |
|----------------------|-------------|
| Numbers of Oven Rack | 1 |
| Total BTU | 35,000 |
| Control Type | Maunal |
| Gas Inlet Size | 3/4" |
| Power Type | Natural Gas |

CONSTRUCTION

| | |
|-------------------|-----------------|
| Exterior Material | Stainless Steel |
| Frame Structure | Welded |
| Number of Legs | 4 |

TECHNICAL DRAWING

MODEL: SR-SM36

MFR MODEL:



Front View

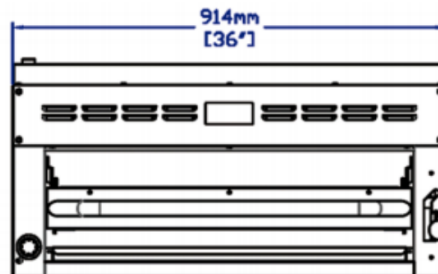

Side View

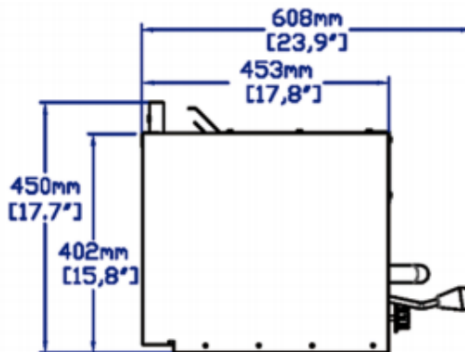

Top View

