

SPACEMAN^{USA}

COMMERCIAL ICE CREAM & FROZEN BEVERAGE EQUIPMENT

PARTS LIST



MODEL SM-6378H

SOFT SERVE - FLOOR STANDING - DOUBLE FLAVOR

Customer Service

Sunday – Saturday
8 AM – 5 PM Mountain

Toll-Free: +1 (888) 610-5520
Local: +1 (720) 328-1020

service@spacemanusa.com

Spaceman USA, LLC

226 Commerce Street
Suite B
Broomfield, CO 80020

Sales and Product Information

Monday – Friday
8 AM – 5 PM Mountain

Toll-Free: +1 (888) 610-5520
Local: +1 (720) 328-1020

sales@spacemanusa.com
info@spacemanusa.com

TROUBLESHOOTING

PROBLEM: STOP 1 - LOW TEMP PROTECT

Probable Cause

1. Inadequate mix in hopper
2. Improper mixing of product
3. Air Tube is not installed correctly
4. Viscosity adjustment is set incorrectly
5. Product being drawn too quickly

Remedy

1. Ensure hopper is at least half full
2. Follow manufacturer instructions for mixing product; ensure correct mix ratios
3. Clean Air Tube, ensure proper orientation
4. Lower viscosity setting as required (Page 17)
5. Ensure Air Tube not clogged, allow machine 2-3 seconds in between servings.

PROBLEM: STOP 2 - MOTOR OVERLOAD

Probable Cause

1. Viscosity adjustment is set incorrectly
2. Inadequate mix in hopper
3. Improper mixing of product
4. Air Tube is not installed correctly
5. Product being drawn too quickly

Remedy

1. Lower viscosity setting as required (Page 17)
2. Ensure hopper is at least half full
3. Follow manufacturer instructions for mixing product; ensure correct mix ratios
4. Clean Air Tube, ensure proper orientation
5. Ensure Air Tube not clogged, allow machine 2-3 seconds in between servings to recover.

PROBLEM: PRODUCT TOO SOFT

Probable Cause

1. Machine not cleaned/lubricated adequately
2. Inadequate mix in hopper
3. Improper mixing of product
4. Machine does not have adequate ventilation
5. Viscosity adjustment is set incorrectly

Remedy

1. Clean and properly lubricate machine daily
2. Ensure hopper is at least half full
3. Follow manufacturer instructions for mixing product; ensure correct mix ratios
4. Ensure at least 6" of clearance on all sides
5. Raise viscosity setting as required (Page 17)

PROBLEM: HOPPER NOT COLD ENOUGH

Probable Cause

1. Warm Product Recently Added
2. Hopper Temperature Setting too High
3. Temperature Offsets need adjustment

Remedy

1. Allow at least 1 hour after adding new mix for hopper temperatures to stabilize
2. Adjust Hopper Temperature down.
3. Call Spaceman Technical Support

PROBLEM: HOPPER FREEZING

Probable Cause

1. Inadequate Mix in Hopper
2. Hopper Temperature Setting too Low

Remedy

1. Ensure hopper is at least half full
2. Adjust Hopper Temperature Up

PROBLEM: MACHINE MAKING NOISE

Probable Cause

1. Improper Assembly
2. Wearable Parts Need Replacement
3. Internal Cleaning / Maintenance Required
4. Damaged Internal Parts

Remedy

1. Stop machine use, drain product with machine powered OFF. Clean and Inspect Parts.
2. Replace wearable parts with new Tune-Up Kit and Scraper Blades at least once every 3 months
3. Contact Spaceman USA Technical Support
4. Inspect parts carefully for damage, ensure proper assembly. Replace as required.

PROBLEM: STOP 4 - TEMPERATURE

Probable Cause

1. Malfunctioning Temperature Probe

Remedy

1. Replace Temperature Probe

PROBLEM: STOP 6 - MOTOR AMP

Probable Cause

1. Malfunctioning Power Board

Remedy

1. Replace Power Board

PROBLEM: PRODUCT LEAKS EXCESSIVELY INTO INTERNAL DRIP TRAY

Probable Cause

1. Improper or inadequate lubrication of drive shaft gasket
2. Damaged, missing, or improperly installed drive shaft gasket

Remedy

1. Use sufficient food-grade lubricant, and add sufficient lubricant inside drive shaft gasket during assembly (Page 11)
2. Replace drive shaft gasket every 1 to 3 months; replace torque assembly guide every 1 to 3 months

PROBLEM: PRODUCT LEAKS EXCESSIVELY FROM DISPENSING DOOR SPOUT

Probable Cause

1. Improper or inadequate lubrication of draw valve and draw valve O-rings.
2. Cracked, broken, or worn draw valve O-rings

Remedy

1. Use sufficient food-grade lubricant when assembling draw valve (Page 12)
2. Replace O-rings every 1 to 3 months

PROBLEM: MACHINE SHUTS DOWN AUTOMATICALLY

Probable Cause

1. Cylinders are experiencing freeze-up (usually due to viscosity being set too high for selected product)

Remedy

1. Reset machine (Page 16), and lower viscosity as required (Page 17)

MACHINE SPECIFICATIONS

SM-6378H

SOFT SERVE FREEZER

PRODUCT INFORMATION

Type	Floor Standing
Flavors	2 + Twist
Cooling	Air Cooled
Freezing Cylinders	2x 3.2 L / 3.4 qt
Product Mix Hoppers	2x 15.0 L / 15.9 qt
Output (4oz Servings)	80.0 qt / hr 642 servings / hr
Motor	2x 1.00 HP, 750W
Compressor (Main)	2x 6500 BTU, R404A
Compressor (Auxilliary)	1x 480 BTU, R134A

FEATURES

Machine Controls	Dual, Digital
Refrigerated Hopper	Yes, Digital Control
Hopper Agitator	Yes
Temperature Display	Yes
Standby Mode	Yes
Low Mix Indicator Light	Yes
Low Mix Indicator Alarm	No
Low Temperature Protection	Yes
Motor Amperage Protection	Yes, Mechanical
High Pressure Protection	Yes
Thermal Overload Protection	Yes



DESCRIPTION

A high capacity, twin-twist, gravity feed, floor standing soft serve freezer. Capable of producing a variety of products including: Soft Serve, Frozen Yogurt, Ice Cream, Custards, and Sorbets.

Independent digital control systems automatically regulate and maintain consistent product quality on each side. Refrigerated hoppers and Standby Mode keeps product fresh, even overnight.

CUSTOM OPTIONS

Air Pump, Water Cooled, Air Chute, Spinner (1 or 2), 3-Phase Power, Dual Plug

ELECTRICAL SPECIFICATIONS

	Maximum Fuse Size	Min. Circuit Ampacity	Poles (P) Wires (W)
208-230/60/1	1 x 30A	1 x 24A	2P / 3W
208-230/60/3	1 x 30A	1 x 20A	3P / 4W

Electrical Plug: 1x NEMA L6-30 (2P) or 1x NEMA L15-30 (3P)

SIZE SPECIFICATIONS

	Machine		Shipping	
Weight	225 kg	496 lbs	245 kg	540 lbs
Depth (mm / in)	702*	27.7*	895	35.3
Width (mm / in)	532*	21.0*	715	28.2
Height (mm / in)	1562	61.5	1740	68.5

Shipping Volume: 1.15 CBM / 39.4 CBF

* Machine Requires Minimum 6" Clearance on all sides

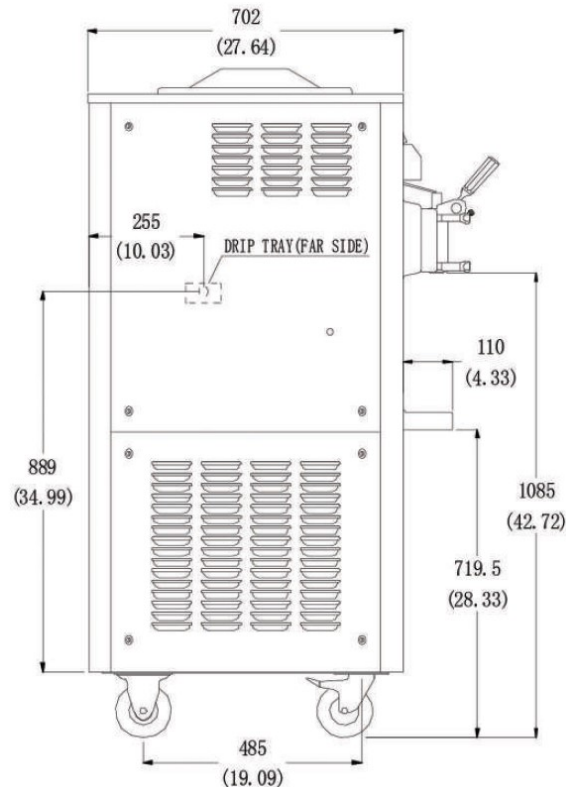
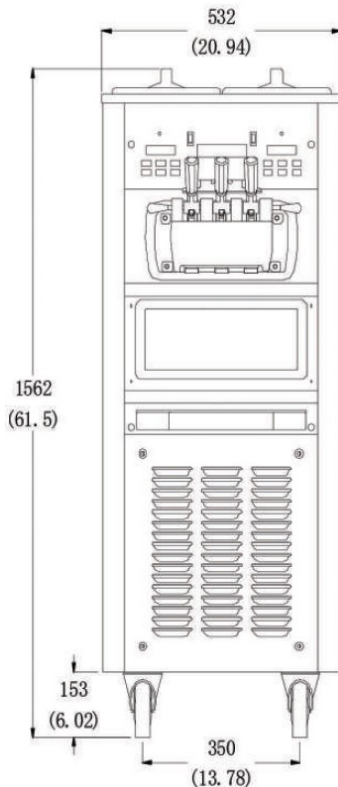

SPECS—EXTERNAL PARTS

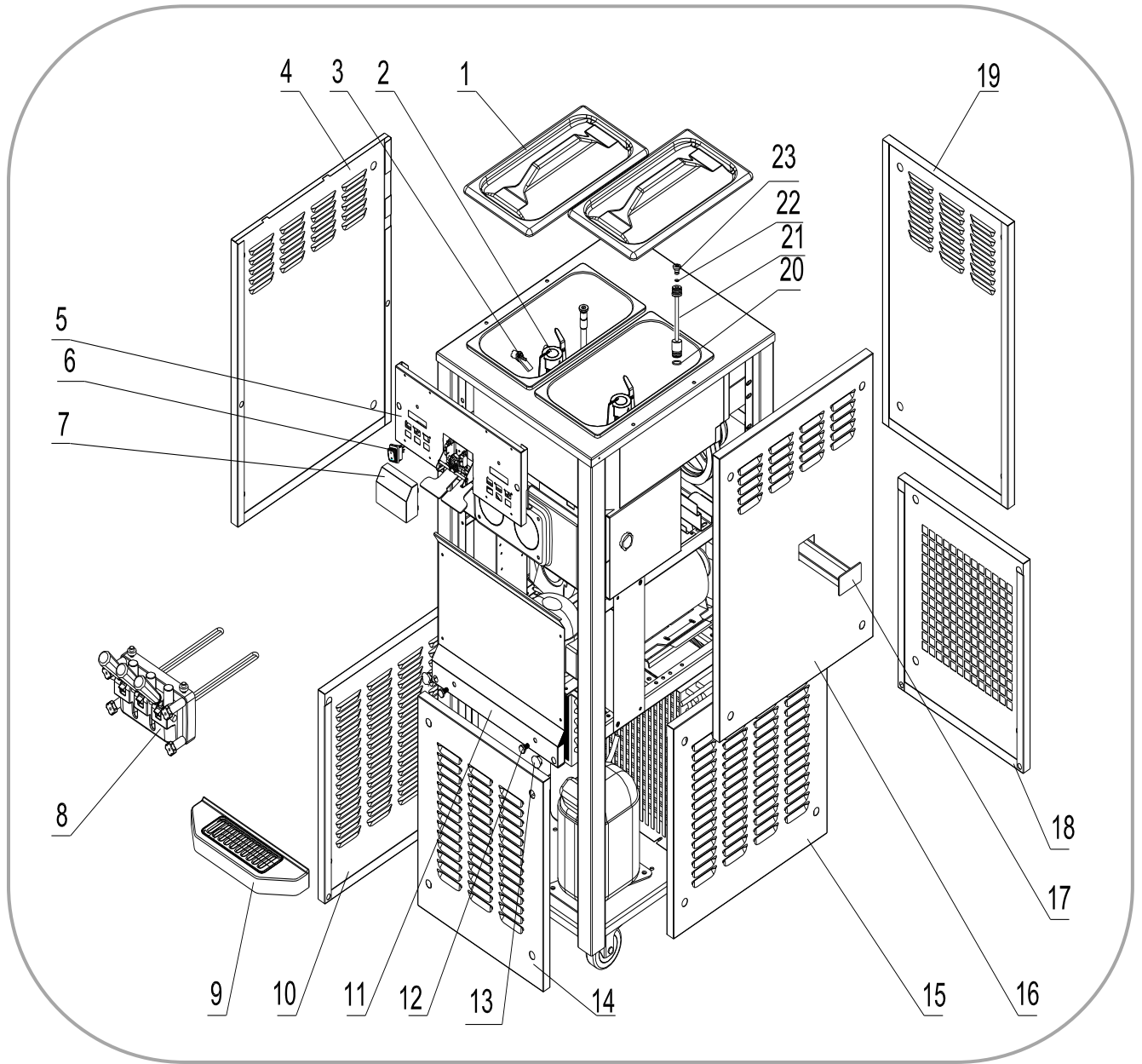

Item	Part #	Description	Item	Part #	Description	Item	Part #	Description
1	3.4.03.01.004	Hopper Lid	9	3.4.04.01.003	Drip Tray	17	3.4.04.02.001	Internal Drip Tray
2	2.1.1.23.0001	Agitator Blade	10	2.3.4.22.003	Panel - Left - L	18	2.3.4.15.003	Panel - Rear - L
3	3.1.03.04.009	Low Mix Sensor	11	2.3.4.16.004	Panel - Front - M	19	2.3.4.14.003	Panel - Rear - U
4	2.3.4.19.003	Panel - Left - U	12	3.6.39.004	Drip Tray Mount	20	3.4.08.01.002	O-Ring - Air Tube
5	2.3.4.07.008	Panel - Front - U	13	3.4.07.01.001	Bolt Cover	21	2.1.1.22.0003	Air Tube
6	3.1.03.03.004	Power Switch	14	2.3.4.17.010	Panel - Front - L	22	3.4.08.01.028	O-Ring - Cap
7	3.4.07.07.004	Switch Cover	15	2.3.4.22.003	Panel - Right - L	23	2.1.3.23.0001	Air Tube Cap
8	2.1.1.15.0005	Dispensing Door	16	2.3.4.21.003	Panel - Right - U			

SPECS—OPERATING PARTS

Dispensing Door and Beater

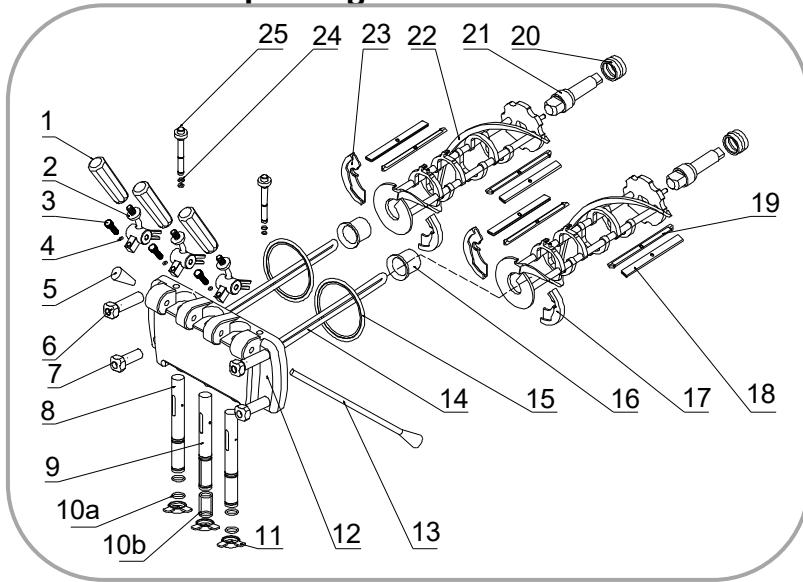

Item	Part #	Description	Item	Part #	Description
1	3.4.05.01.001	Dispensing Handle	13	2.1.3.27.0003	Retention Pin
2	2.1.3.26.0002	Handle Seat	14	2.1.1.11.0002	Beater Rod
3	3.6.39.008	Adjustment Screw	15	3.4.08.02.003	Door Gasket
4	3.4.08.01.012	O-Ring - Screw	16	3.4.01.03.002	Beater Guide
5	2.1.3.27.0025	Nut - Retention Pin	17	3.4.01.02.001	Beater Shoe - R
6	3.4.05.02.004	Hand Screw - Long	18	3.4.02.01.001	Scraper Blade
7	3.4.05.02.003	Hand Screw - Short	19	2.3.4.04.002	Scraper Blade Clip
8	2.1.3.01.0005	Draw Valve - Side	20	3.4.07.05.002	Drive Shaft Gasket
9	2.1.3.02.0002	Draw Valve - Mid	21	2.1.3.25.0002	Drive Shaft
10a	3.4.08.01.006	O-Ring - Valve - S	22	2.1.1.10.0001	Beater
10b	3.4.08.01.015	H-Ring - Valve	23	3.4.01.01.001	Beater Shoe - L
11	3.4.05.03.004	Star Cap - Small	24	3.4.08.01.013	O-Ring - Prime
12	2.1.3.14.0005	Dispensing Door	25	2.1.3.02.0015	Prime Plug

Hopper Agitator

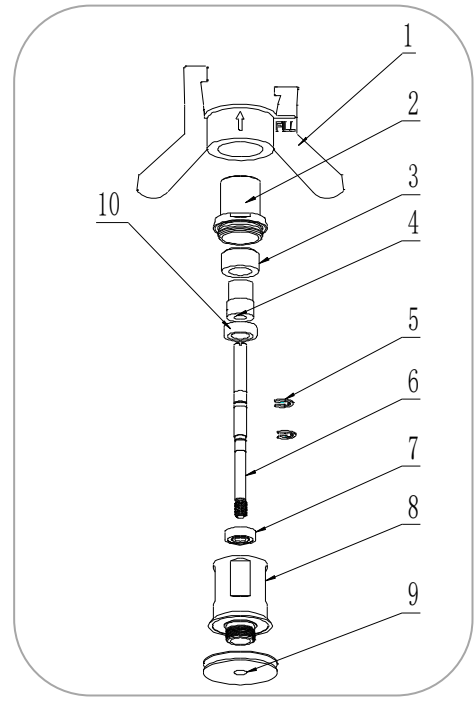

Item	Part #	Description
1	2.1.1.23.0001	Agitator Blade
2	2.1.4.02.005	HA Housing Cap
3	2.1.4.02.002	HA Main Magnet
4	2.1.4.02.003	HA Shaft Magnet
5	3.6.34.003	C-Clip
6	2.1.3.42.0001	Drive Shaft
7	3.3.02.07.004	HA Bearing - Lower
8	2.1.4.02.001	HA Housing
9	2.1.4.02.015	Pulley - HA
10	3.3.02.07.003	HA Bearing - Upper
11	2.1.4.02.016	Pulley - Double

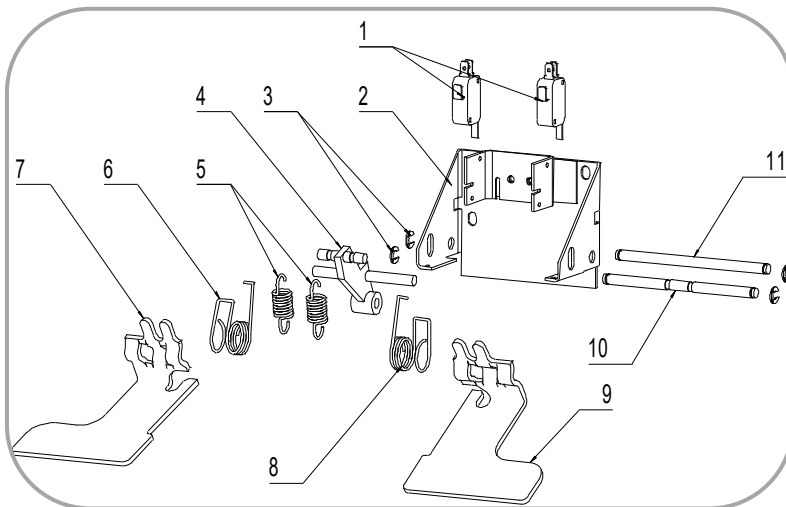

Item	Part #	Description
1	3.1.03.01.004	Switch - Draw
2	2.1.1.19.0010	Switch Mount
3	3.6.34.002	C-Clip - #6
4	2.1.1.19.0006	Draw Switch Lever
5	3.6.02.002	Spring - Draw
6	3.6.01.001	Spring - Return - L
7	2.1.4.05.011	Draw Arm - L
8	3.6.01.011	Spring - Return - R
9	2.1.4.05.012	Draw Arm - R
10	2.1.4.05.001	Retention Pin - F
11	2.1.4.05.002	Retention Pin - R

SPECS—INTERNAL PARTS

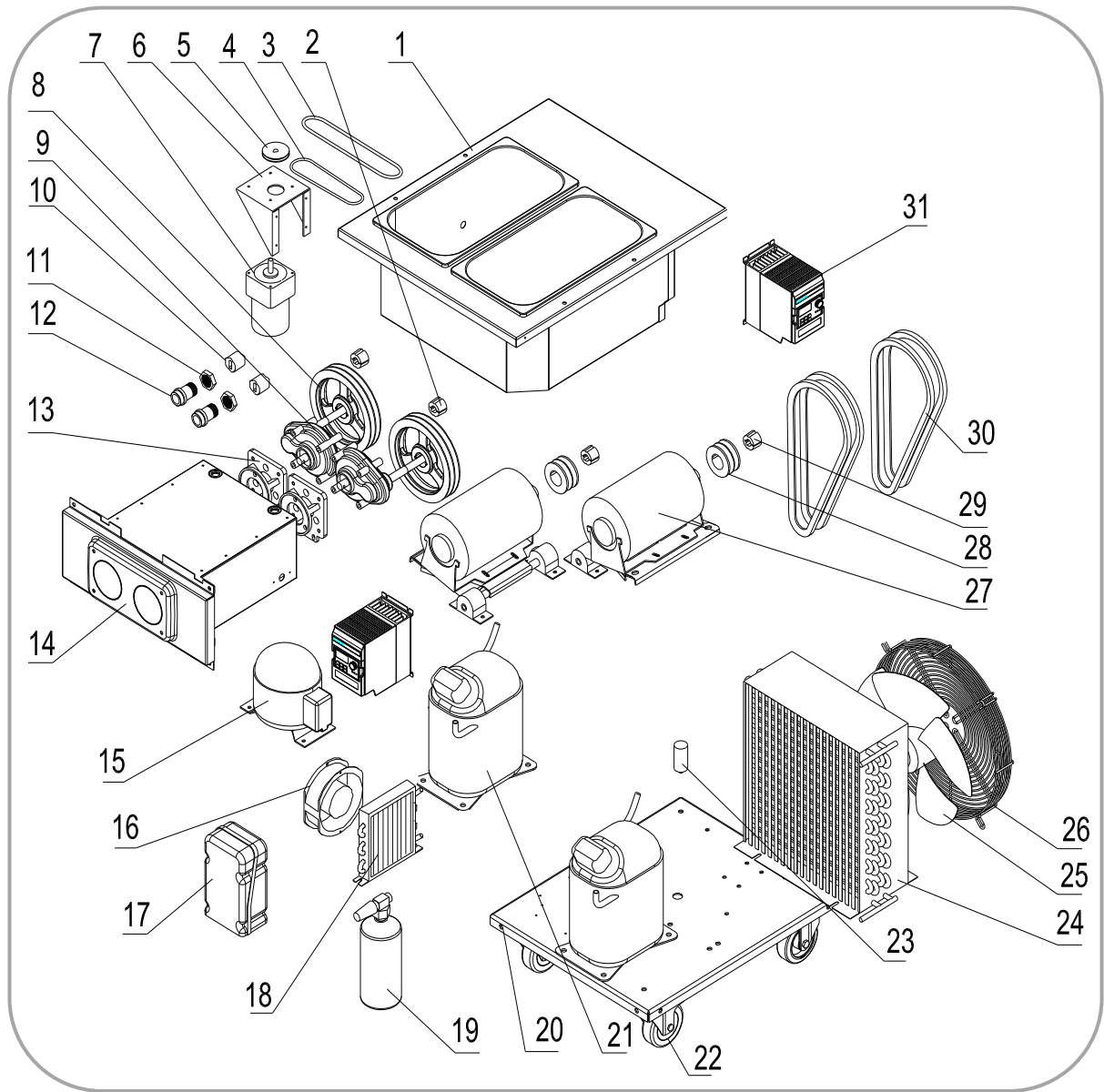

Item	Part #	Description	Item	Part #	Description	Item	Part #	Description
1	2.1.1.05.0031	Hopper Assembly	13	2.1.3.15.0003	Gear Box Mount	25	3.2.03.04.001	Fan Motor - Main
2	3.3.04.01.005	Bushing - 1008-16	14	2.1.1.06.0045	Cylinder Assembly	26	3.2.03.04.001-1	Fan Cover
3	2.1.4.08.021	Belt - HA - 630mm	15	3.2.01.01.002	Compressor - Aux	27	3.3.01.04.005	Motor - 750W
4	2.1.4.08.002	Belt - HA - 360mm	16	3.2.03.01.001	Fan Motor - Aux	28	3.3.04.02.001	Pulley - 63x2-1008
5	3.3.04.04.008	Pulley - HA - 34mm	17	3.2.01.04.004	Start Component	29	3.3.04.01.005	Bushing - 1008
6	2.3.4.45.007	HA Motor Mount	18	3.2.02.01.001	Condenser - Aux	30	3.3.03.01.003	Belt - XPA1030
7	3.3.01.01.001	HA Motor	19	3.2.04.08.001	Liquid Receiver	31	3.1.01.08.006	Inverter - 0.5KW
8	3.3.04.02.007	Pulley - 182x2-1008	20	2.2.4.01.0011	Chassis			
9	3.3.02.01.002	Gear Box	21	3.2.01.02.005	Compressor - Main			
10	3.3.02.04.002	Drive Coupling	22	3.3.05.02.002	Caster - Swivel			
11	3.3.02.02.010	Nut - RS Bearing	23	3.2.03.04.001-2	Capacitor - Fan			
12	3.3.02.02.002	Rear Shell Bearing	24	3.2.02.01.009	Condenser - Main			

SPECS—AIR PUMP PARTS

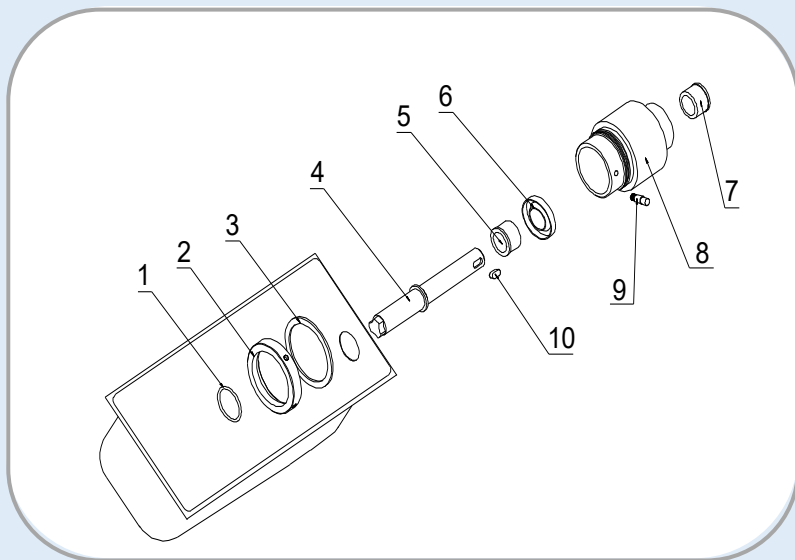

Item	Part #	Description
1	3.4.08.03.010	Nylon Ring - Shaft
2	2.1.4.01.016	Nut - Pump Seat
3	3.4.08.03.012	Nylon - Pump Seat
4	2.1.4.01.018	Drive Shaft - Pump
5	3.3.02.06.001	Bearing - Front
6	3.3.02.09.002	Bearing Gasket
7	3.3.02.06.001	Bearing - Rear
8	2.1.4.01.017	Air Pump Seat
9	3.6.39.010	Lock Pin
10	3.6.33.002	Drive Shaft Key

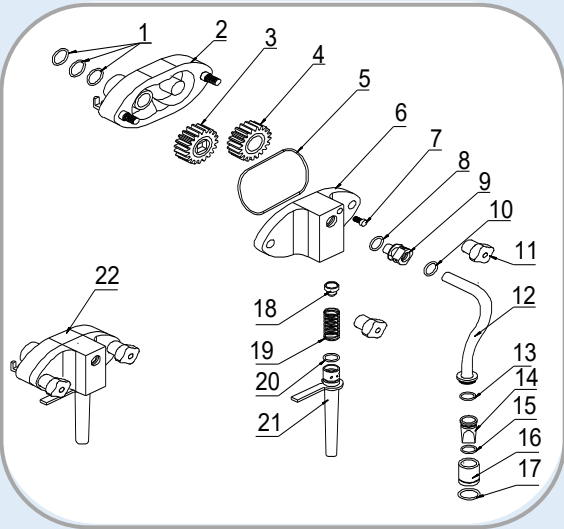

Item	Part #	Description	Item	Part #	Description
1	3.4.08.01.025	O-Ring	12a	2.1.4.01.044	Air Tube - Right
2	2.1.4.01.004	Air Pump Shell	12b	2.1.4.01.043	Air Tube - Left
3	2.1.4.01.013	Driving Gear	13	3.4.08.01.003	O-Ring - Tube
4	2.1.4.01.012	Driven Gear	14	2.1.4.01.035	Check Valve
5	3.4.08.01.004	Air Pump Gasket	15	3.4.08.01.023	O-Ring - Valve
6	2.1.4.01.003	Air Pump Cover	16	2.1.4.01.039	Connector - Hopper
7	2.1.4.01.029	Lock Nut	17	3.4.08.01.037	O-Ring - Connector
8	3.4.08.01.003	O-Ring - Connector	18	3.4.07.06.003	Plug
9	2.1.4.01.023	Connector—Pump	19	3.6.03.003	Spring
10	3.4.08.01.008	O-Ring - Connector	20	3.4.08.01.003	O-Ring - Suction
11	2.1.4.01.002	Hand Screws	21	2.1.4.01.049	Suction Tube - 200
			22	2.1.1.13.0001	AP Assembly

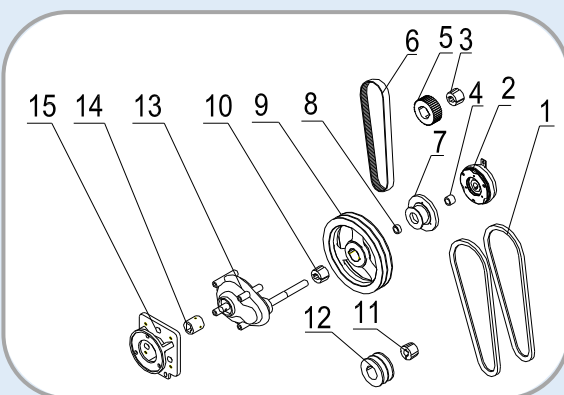

Item	Part #	Description	Item	Part #	Description
1	3.3.03.01.014	Belt - XPA1080	9	3.3.04.02.008	Pulley - 212x2-1210
2	3.1.01.06.001	Micro Clutch	10	3.3.04.01.007	Bushing - 1210
3	3.3.04.01.005	Bushing - 1008	11	3.3.04.01.005	Bushing-1008
4	3.3.04.06.001	Bushing - Clutch	12	3.3.04.02.001	Pulley - 63x2-1008
5	3.3.04.03.001	Pulley - 63-5-1008	13	3.3.02.01.007	Gear Box - Long
6	3.3.03.02.005	Belt - 5M780	14	3.3.02.04.002	Drive Coupling
7	3.3.04.03.002	Pulley - 50-5M	15	2.1.3.15.0003	Gear Box Mount
8	3.3.04.06.002	Bushing - Clutch			

SPECS—WIRING - LEFT

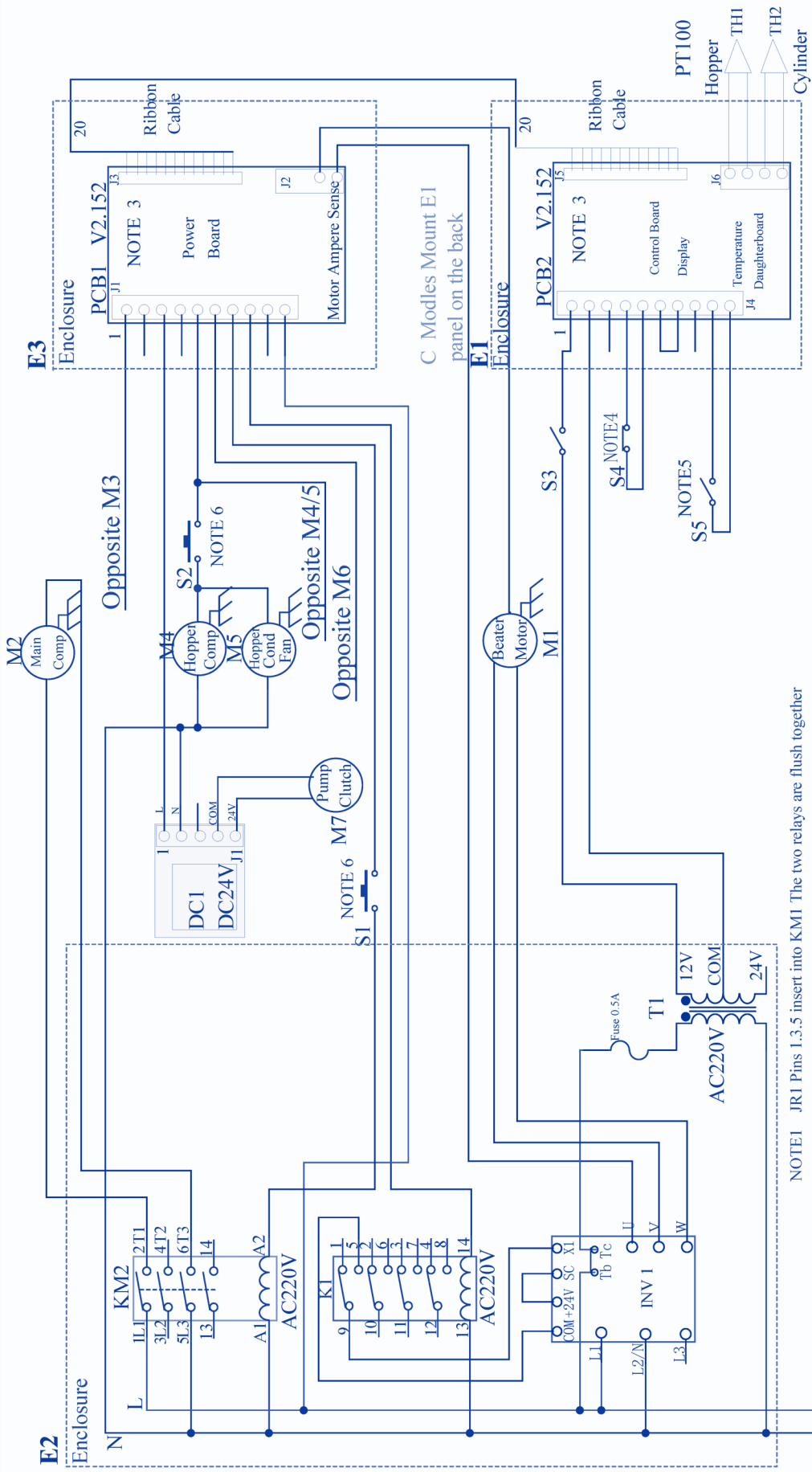

Wiring Diagram - SM-6378H - Left

- NOTE1 JRI Pins 1,3,5 insert into KM1 The two relays are flush together
- NOTE2 Motor Start and Run capacitors included in Motor Assembly C1 and C2 Values are on the face plate of the Motor
- NOTE3 No Pin Markings on the Connector Pins 1 is left when facing edge of PC component side up.
- NOTE4 Front Panel Dispenser Levers which mechanically actuates S4
- NOTE5: Switches inside hoppers which activate "Mix Low" indicator
- NOTE6: Compressor Inline Over Pressure Switch

- Enclosure Locations**
- E1 Front Panel
 - E2 Upper Left
 - E3 Middle Left

Item	Part #	Description	Item	Part #	Description	Item	Part #	Description
M1	3.3.01.04.005	Motor - 750W	M6	3.3.01.01.001	Agitator Motor	TH	3.1.02.13.020	Thermostat
M2	3.2.01.02.005	Compressor	M7	3.1.01.06.001	Micro Clutch	PC1	2.2.1.01.0007	Power Board
M3	3.2.03.04.001	Fan Motor - Main	INV	3.1.01.08.006	Inverter	PC2	2.2.1.01.0004	Control Board
M4	3.2.01.01.002	Compressor - Aux	KM	3.1.01.01.010	Contactors	S1/2	3.2.04.06.004	Pressure Switch
M5	3.2.03.01.001	Fan Motor - Aux	T	3.1.01.04.007	Transformer	S3	3.1.03.03.004	Power Switch
						S4	3.1.03.01.004	Draw Switch
						S5	3.1.03.04.009	Low Mix Sensor
						F	3.1.02.08.002	Fuse - 0.5A
						DC	3.1.01.05.004	Transformer

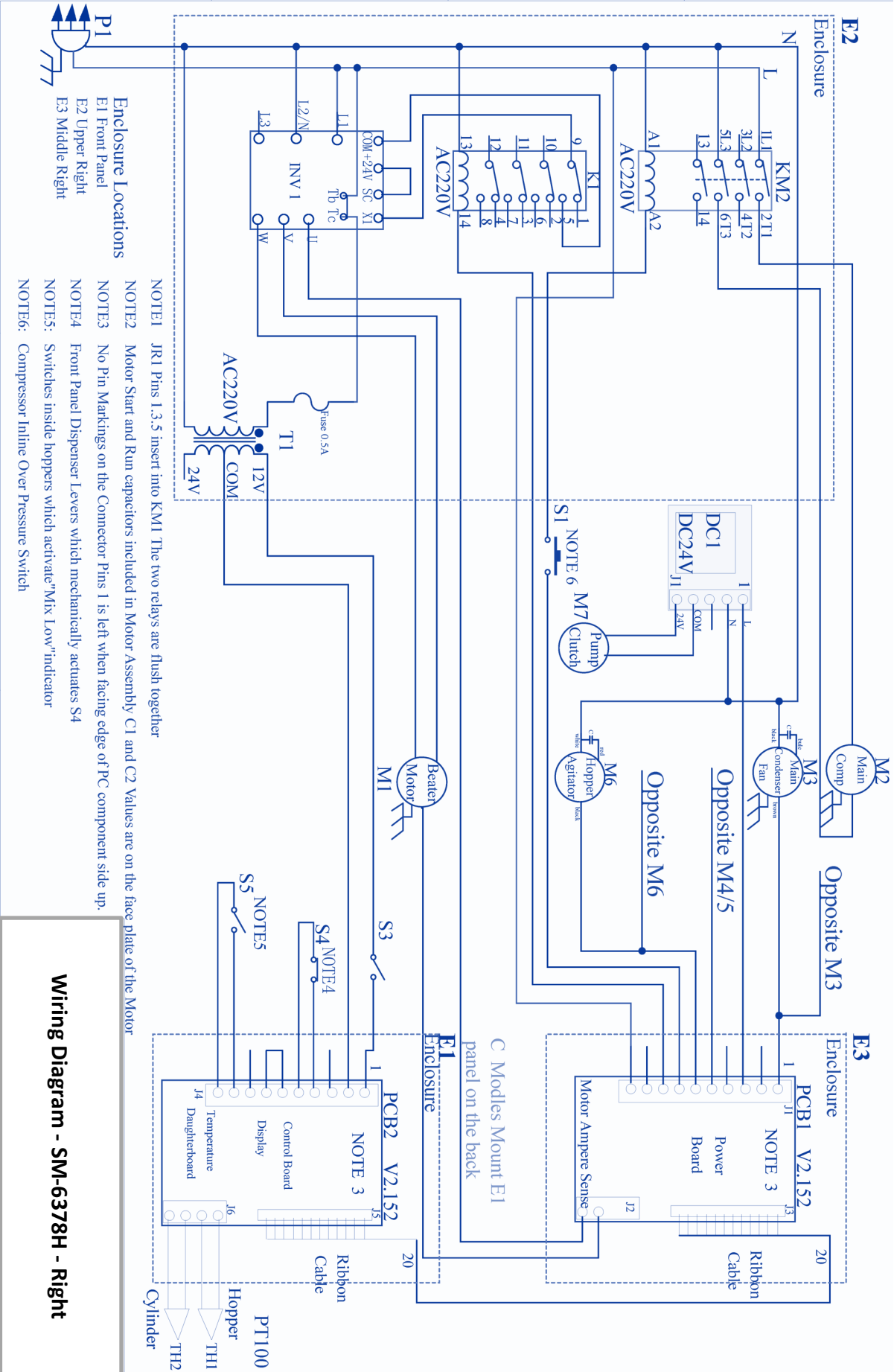

Item	Part #	Description	Item	Part #	Description	Item	Part #	Description
M1	3.3.01.04.005	Motor - 750W	M6	3.3.01.01.001	Agitator Motor	TH	3.1.02.13.020	Thermostat
M2	3.2.01.02.005	Compressor	M7	3.1.01.06.001	Micro Clutch	PC1	2.2.1.01.0007	Power Board
M3	3.2.03.04.001	Fan Motor - Main	INV	3.1.01.08.006	Inverter	PC2	2.2.1.01.0004	Control Board
M4	3.2.01.01.002	Compressor - Aux	KM	3.1.01.01.010	Contactors	S1/2	3.2.04.06.004	Pressure Switch
M5	3.2.03.01.001	Fan Motor - Aux	T	3.1.01.04.007	Transformer	S3	3.1.03.03.004	Power Switch

