

SOMERSET

Tel: 978.667.3355

800.772.4404

Fax: 978.671.9466

Email: somerset@smrset.com

www.smrset.com



CDR-1550

DOUGH ROLLER

IDEAL FOR PIZZA AS WELL AS:

- Flour Tortillas
- Sheeting
- Cinnamon Rolls
- Pita Bread
- Pie Crusts
- Cookies
- Calzones
- Sweet Doughs
- Pierogi
- Rolled In Dough

HIGHLIGHTS:

- Sheets 500-600pcs per hour up to 15" (38cm)
- Ships standard with synthetic, non-stick rollers
- Ergonomic design makes it easy and simple to operate
- Sheets dough to a uniform thickness in seconds
- All stainless steel construction offers safety, sanitation, speed, simplicity, durability, and low cost



SOMERSET INDUSTRIES, INC. • 1 ESQUIRE ROAD • NORTH BILLERICA, MA 01862 • U.S.A.

SOMERSET

DOUGH ROLLER

CDR-1550

CDR-1550 SYNTHETIC ROLLERS

CDR-1550M METALLIC ROLLERS

FEATURES

- Simple handle adjustments for exact uniform dough thickness
- Spring loaded scrapers readily removable for easy cleaning
- Safety sensors for automatic shutoff
- Compact design, ideal for use in limited space
- Ergonomic design for easy operation
- Convenient front operation
- Large hopper accepts large pieces of dough
- Maintenance free drive mechanism
- Drive mechanism isolated from roller area
- Sanitary, heavy duty, all stainless steel welded construction
- Safe, simple, easy to operate, easy to clean



INDUSTRY USES

- Pizzerias
- Restaurants
- Institutions
- Schools
- Mexican establishments
- Other ethnic food production
- Cafes
- Bakeries

SPECIFICATIONS

(Specifications subject to change without notice)

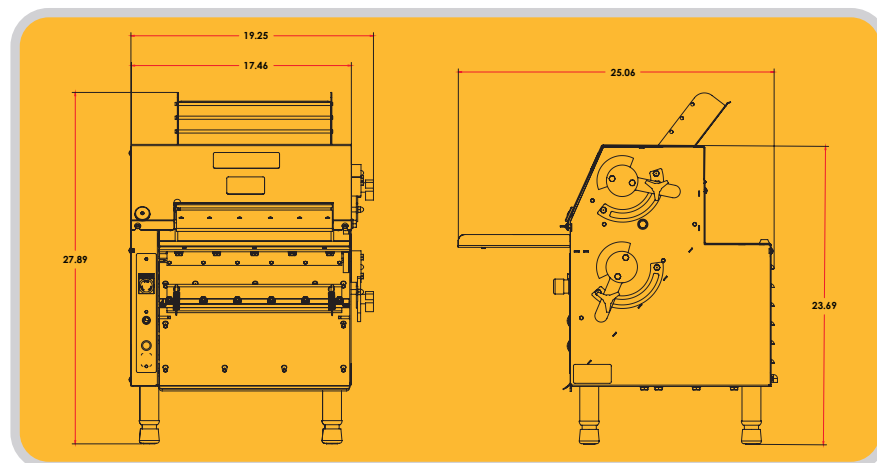

Rollers: 3.5" dia. by 15" length
(8.89 cm dia. by 38.10 cm length)

Scrapers: Synthetic, Spring Loaded, Removable

Bearings: Sealed Ball Bearings, Permanently Lubricated

Gear Motor: Heavy Duty 1/2 HP, Maintenance Free, Single Phase, 115v/60Hz or 220v/50Hz

Finishing: All Stainless Steel

Legs: 4" Adjustable, Stainless Steel

Shipping Weight: 170 lbs (77kgs)



MADE IN THE U.S.A. 05.10.12