



PROJECT NAME: _____

LOCATION: _____

ITEM: _____ QTY: _____

MODEL: _____

SRCO-E SRCO-2E

ELECTRIC CONVECTION OVENS

The SRCO features a modern look and design, form and function for the most demanding kitchens at an affordable price.

The SRCO-E Single Oven comes with the SRCO-LK leg kit, including 4 legs with locking casters

The SRCO-2E Double Stacked Ovens come with the SRCO-SK stacking kit, including heavy duty casters (locking in front), separator tray, exhaust flue extension and mounting hardware.



SRCO-E with 118-SRCOLK



SRCO-2E with 118-SRCOSK

STANDARD FEATURES

- 🔥 Power 10kW, 208-240V/60Hz/1/3 phase(cordset not included, must be hardwired.
- 🔥 26" legs on single stack unit for easy access.
- 🔥 Electronic ignition
- 🔥 Dial type easy to use thermostat
- 🔥 Temperature range 150-500°F(65-260°C)
- 🔥 Electronic one hour timer with alarm buzzer to alert employees and prevent overcooking
- 🔥 Two Halogen interior lights
- 🔥 Independent doors with full view windows
- 🔥 2-speed, 1/2 hp fan motor (1724, 1140 rpm) for even heat distribution Forced "cool down" fan mode
- 🔥 Exterior stainless front, top and sides
- 🔥 Porcelain enamel interior for easy cleaning
- 🔥 5 Nickel plated Heavy Duty Racks with eleven position interior rack guide
- 🔥 Single or three phase connection Insulated
- 🔥 Cooking chamber reduces heat loss and saves energy
- 🔥 ETL Safety and Sanitation Certified.



Tel.: 786.600.4687 / Toll Free: 844.218.8477
Fax: 786.661.4100



Tel.: 514.737.9701 / Toll Free: 888.275.4538
Fax: 514.342.3854 / Toll Free: 877.453.8832
sales@mvpgroupcorp.com



www.mvpgroupcorp.com

TECHNICAL DRAWINGS

SPECIFICATIONS

MODEL NUMBER	SRCO-E	SRCO-2E
EXTERNAL DIMENSIONS (WxDxH)	38.12" X 44.37" X 60"	38.12" X 44.37" X 65.62"
INTERNAL DIMENSIONS (WxDxH)	29" X 22.5" X 19.75"	29" X 22.5" X 19.75"
RACK CLEARANCE	28" WIDTH, 21" DEPTH	28" WIDTH, 21" DEPTH
SHIPPING WEIGHT	510 LBS	1240 LBS
<u>LEG OR STACKING KITS</u>		
SINGLE OVEN - 118-SRCOLK	29.9" X 18.1" X 8.7" H, 2.7 cu ft. 41 lbs.	
DUAL OVEN - 118-SRCOSK	38.2" X 11.8" X 6.7" H, 1.7 cu ft. 35 lbs.	

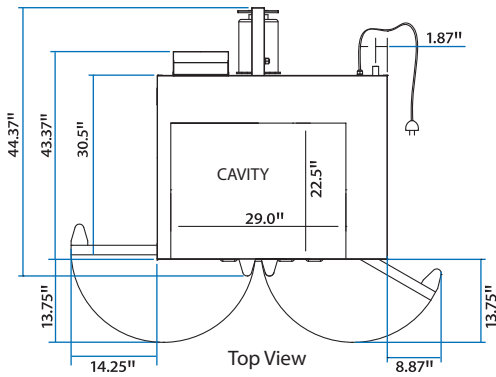

Single Oven with Leg Kit

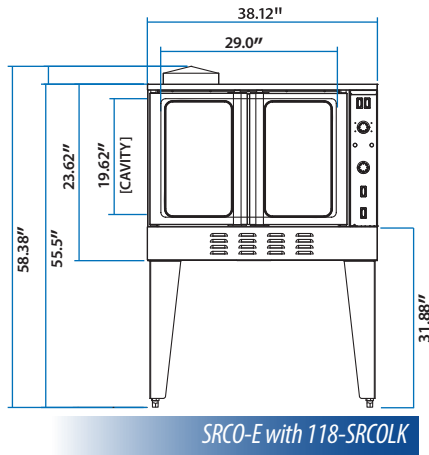

SRCO-E with 118-SRCOLK

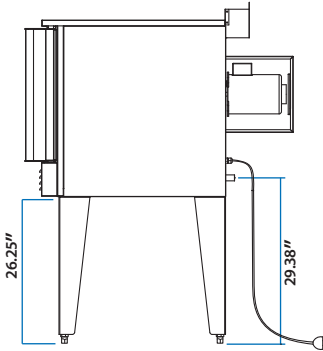

Dual Oven Configuration with Stacking Kit

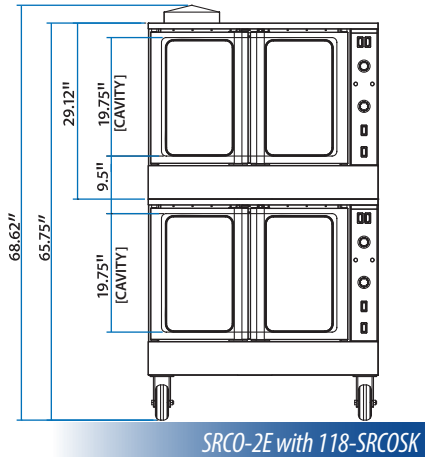

SRCO-2E with 118-SRCOSK

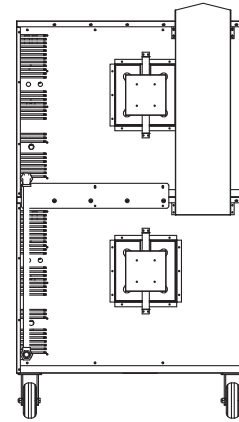
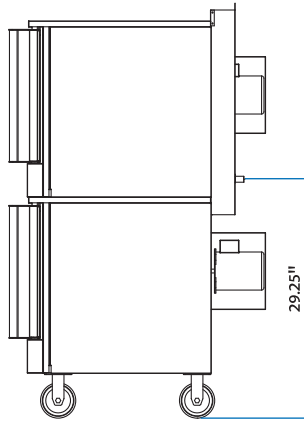

Intertek



Intertek

Warranty: 12 months parts & labor.

Electrical Specifications:

Voltage: 240V, Power: 10KW, Amps Single Phase: 46A, Amps Three Phase: 27A
Voltage: 208V, Power: 10KW, Amps Single Phase: 53A, Amps Three Phase: 31A

SIERRA RANGE is a registered trademark of **MVP Group**.

Due to continuing product development, to ensure best possible performance, the specifications are subject to change without prior notice.



Tel.: 786.600.4687 / Toll Free: 844.218.8477
Fax: 786.661.4100



Tel.: 514.737.9701 / Toll Free: 888.275.4538
Fax: 514.342.3854 / Toll Free: 877.453.8832
sales@mvpgroupcorp.com