

Project:	Quantity:
Model #:	Approval:

For Commercial Use Only

Prepline ENR6B36L 36" 6 Burner Commercial Gas Range with Oven - Liquid Propane



FEATURES

- 30,000 BTU per top burner
- 12" x 12" cast iron grates
- Standing pilot light for easy start
- 30,000 BTU static oven
- Oven thermostat adjusts from 250°F - 550°F
- Welded frame structure for best stability
- Stainless steel front, back riser, and lift off shelf
- Legs standard
- "Cool-to-the-touch" front s/s deck
- Stainless steel handle for bottom oven
- Easy to remove full width crumb tray
- LP conversion kit included

• cCSAus

• CSA Sanitation



USR Brands is a US supplier of premium quality commercial cooking, refrigeration and food preparation equipment. Our aim is simple. Produce industry-leading commercial restaurant equipment at reasonable prices, and back it all up with an easy to understand, no nonsense warranty that people can count on.

Project:	Quantity:
Model #:	Approval:

For Commercial Use Only

TECHNICAL DATA

DIMENSIONS

Exterior Dimensions	36"L x 32.73"D x 60.36"H
Packaging Dimensions	40.6"L x 40.6"D x 37.3"H
Oven Dimensions	26.8"L x 25.7"D x 13"H
Unit Weight	364 lb.
Shipping Weight	448 lb.

COOKING

Numbers of Burners	6
Burner BTU	30,000
Numbers of Ovens	1
Numbers of Oven Racks	2
Oven BTU	30,000
Oven Style	Standard Oven
Max. Oven Temperature	550°F
Total BTU	210,000
Control Type	Maunal
Gas Inlet Size	3/4"
Power Type	Liquid Propane

Liquid Propane conversion kit included. Range must be converted from NG to LP on premise by a professional.

CONSTRUCTION

Exterior Material	Stainless Steel
Frame Structure	Welded
Pull Out Tray	"Yes"

DIAGRAM

MODEL: ENR6B36L

MFR MODEL: ENR6B36L

Front View

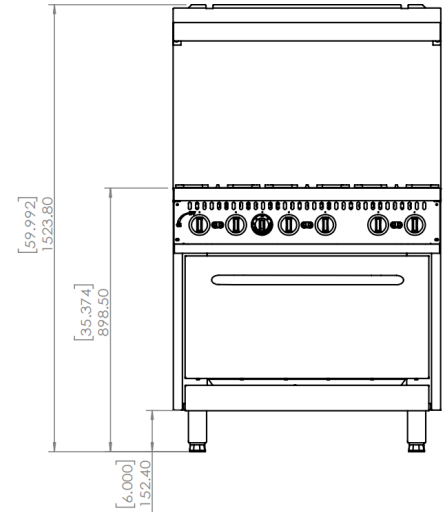

Side View

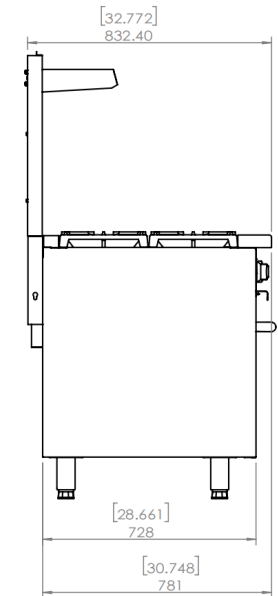

Top View

