

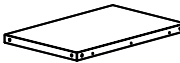

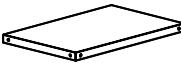







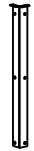

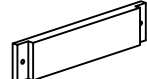

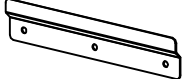
# Assembly Procedure

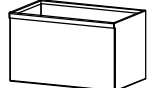
## Parts List

(1) 1pc 	(2) 1pc 	(3) 1pc 	(4) 4pcs 	(5) 1pc 	(6) 2pc 	(7) 1pc 	(8) 1pc 	(9) 1pc 	(10) 1pc 
(11) 1pc 	(12) 1pc 	(13) 2pcs 	(14) 2pcs 	(15) 19pcs 	(16) 10pcs 	(17) 16pcs 	(18) 13pcs 	(19) 8pcs 	

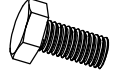
Step1

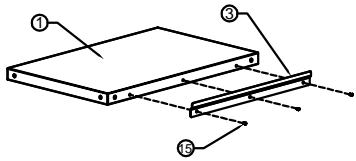

Step2

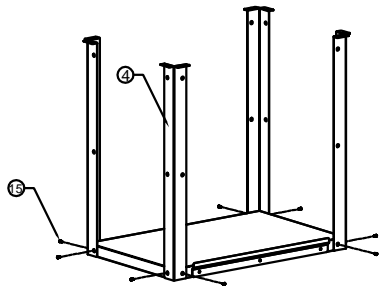

Step3

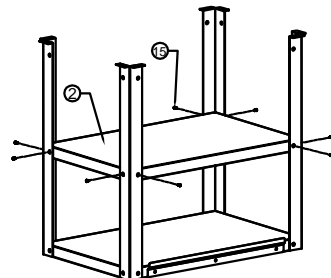

Step4

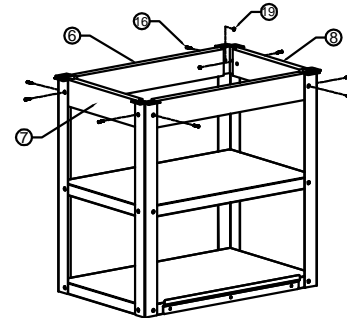

Step5

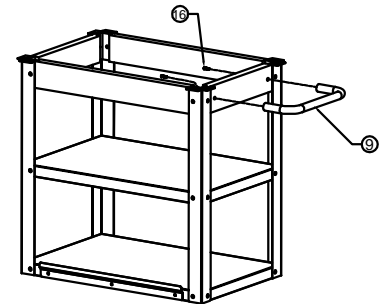

Step6

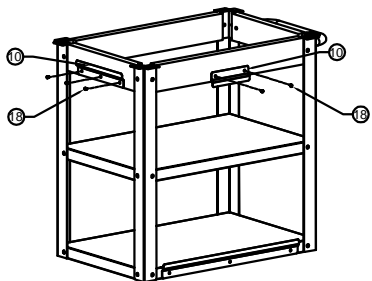

Step7

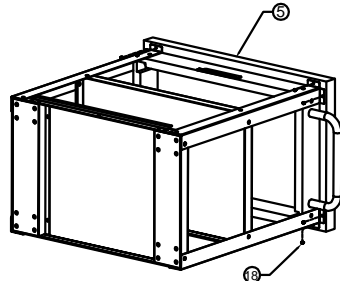

Step8

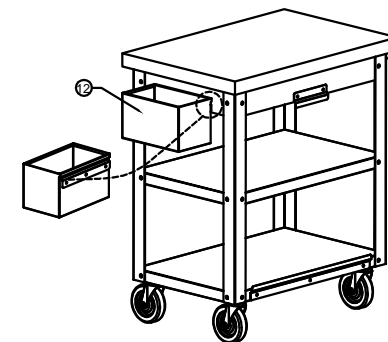
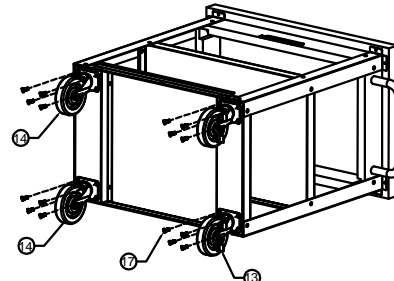

Final Assembly