

**Prepline PMT-2424 24" Stainless Steel Mixer Stand with Marine Edge**



**STANDARD FEATURES**

- High grade Stainless steel body
- Top shelf with 3/8" marine edge at four sides
- Top reinforced with hat channel frame
- Anti-corrosion and water-proof
- Knock-down design easy to assemble
- All edges finished to provide safety
- NSF

This mixer stand provides a stable platform for your mixer while ensuring a clean work environment. Its sturdy construction ensures long-lasting performance, making it ideal for professional use.



**TECHNICAL DATA**

Model	L/D/H	Working Height	Net Weight	Packing Size	Packing Weight	Top Shelf Capacity	Undershelf Capacity	Raised Edge
PMT-2424	24" x 24" x 24"	24"	29 lb.	30.3" x 24.8" x 3.35"	30.5 lb.	700 lb.	540 lb.	3/8"

SKU: PMT-2424  
MFR ITEM #: PMTG-2424-418

**TOP**

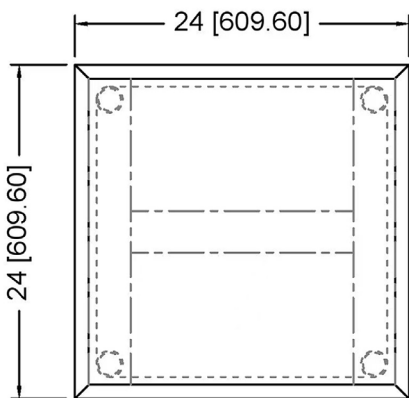

**FRONT**

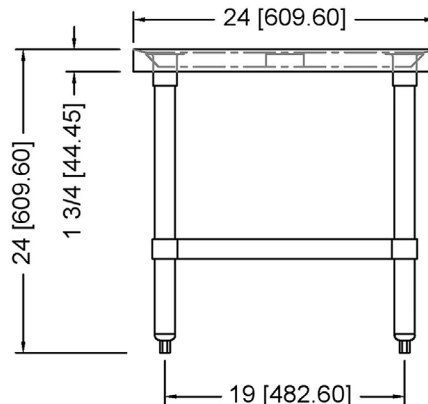

**DETAILS**

