

## PDM2 Double Spindle Commercial Drink Mixer, Milkshake Machine - 120V



### STANDARD FEATURES

- High-performance motor: 400W
- Speed: 10,000&15,000RPM
- Non-skid feet
- Three button: low speed , on/off, high speed
- Durable stainless steel body to keep the machine steady
- 32 oz. stainless steel malt cup included
- Heavy-duty, powder-coated die-cast steel housing

Prepline PDM2 Heavy-Duty Double Spindle Drink Mixer, Milkshake Machine. Make classic milkshakes and malts your customers will love. Power through the coldest, hardest ice cream with ease, thanks to high performance motor.

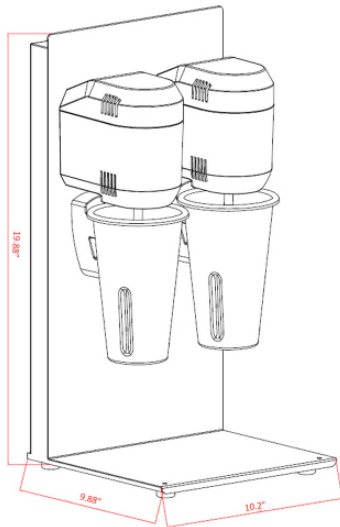

### TECHNICAL DATA

Model	PDM2
Exterior Dimension	10.2" x 9.88" x 19.88"
Net Weight	26 lb.
Voltage/Hertz/Phase	120V/60Hz/1PH
Wattage/Amps	800W/3.636A
Plug Type	5-15P
Cord Length	6"
RPM	10,000 - 15,000RPM
Speed	2
Body Material	Stainless Steel

**U**SR Brands is a US supplier of premium quality commercial cooking, refrigeration and food preparation equipment. Our aim is simple. Produce industry-leading commercial restaurant equipment at reasonable prices, and back it all up with an easy to understand, no nonsense warranty that people can count on.