

Project:	Quantity:
Model #:	Approval:

*For Commercial Use Only*

## MPN1812 Undercounter Half Size Non-Insulated Heater Proofer with Clear Door



### FEATURES

- Digital temperature display
- Manual temperature control
- Manual humidity control
- Corner Bumpers
- Ventilated heating system
- Field-reversible door
- Clear door with aluminum framing
- Humidity from 30%-95%
- Maximum temperature up to 185°F
- Fits 12 Full-Size (18" x 26")
- 4 Casters, 2 with brakes
- Removable control drawer

This Prepline heat display warmer has a manual temperature and humidity control with a digital temperature display. Perfect addition to your business to hold foods at warming temperatures ready to serve.



NSF



UL

**U**SR Brands is a US supplier of premium quality commercial cooking, refrigeration and food preparation equipment. Our aim is simple. Produce industry-leading commercial restaurant equipment at reasonable prices, and back it all up with an easy to understand, no nonsense warranty that people can count on.

For Commercial Use Only

**TECHNICAL DATA**

**DIMENSIONS**

Exterior Dimensions	23"L x 33.15"D x 30.5"H
Interior Dimensions	21"L x 29.3"D x 18.4"H
Packaging Dimensions	24.02"L x 34.25"D x 31.89"H
Unit Weight	90.4 lb.
Shipping Weight	95 lb.

**ELECTRICAL**

Voltage	120
Hertz	60
Phase	1
Wattage	1500
Amps	14
Plug Type	NEMA 5-15P

**Warming**

Control Type	Manual
Temperature Range	Up to 185°F
Humidity Level	30-95%
Insulated	No

**CONSTRUCTION**

Exterior Material	Aluminum
Interior Material	Aluminum
Door Type	Clear
Slide Load	Lip-load
Sheet Pan Capacity	12 Full-Size (18" x 26")
Mobility Wheels/Casters	(4) Qty: 2 with brakes, 2 without

**DIAGRAM**

MODEL: MPN1812

MFR ITEM #: HC1812HP



Front View

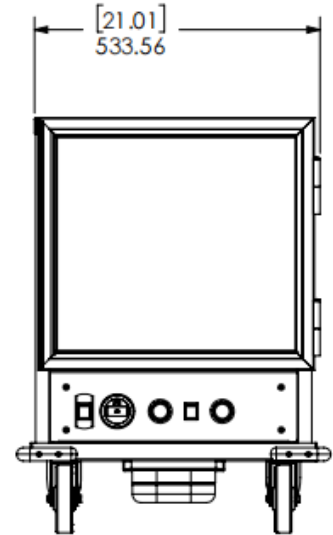

Side View

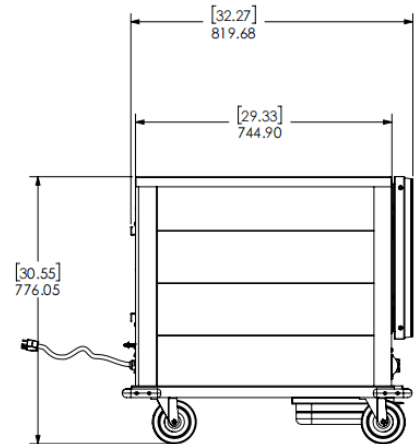

Top View

