

Project:	Quantity:
Model #:	Approval:

For Commercial Use Only

32" Two Well Gas Hot Food Steam Table with Enclosed Base

FEATURES

- Removable 1/2" thick poly cutting board
- Stainless steel cabinet body
- 2 Powerful Jet burners
- Sliding doors with handle
- Legs included, casters optional
- Fiberglass insulation between wells
- Gas regulator included
- Independent heat controls
- Built-in water drain
- Sealed well design for water heat



Optional Lighted Sneeze Guard

- 32" Lighted Heated Sneeze Guard
- Four side tempered glass
- Includes three heat lamp bulbs
- Prevents contamination

This 32" food service glass sneeze guard display features stainless steel frame with four sides tempered glass, allowing customers excellent views of your food from all angles. The standard 120V makes set up easy.



USR Brands is a US supplier of premium quality commercial cooking, refrigeration and food preparation equipment. Our aim is simple. Produce industry-leading commercial restaurant equipment at reasonable prices, and back it all up with an easy to understand, no nonsense warranty that people can count on.

For Commercial Use Only

TECHNICAL DATA

MODEL	Exterior Dimension	Number of Well(s)	Number of Burner(s)	BTU per Burner	Total BTU	Well Type	Body Type
GSTC30-2S	31.8" x 30.6" x 34.4"	2	2	3,500BTU	7,000BTU	Sealed Well	Cabinet

TECHNICAL DRAWING

SKU: **GSTC30-2S**
MFR ITEM #: GST-2SW-CBSD

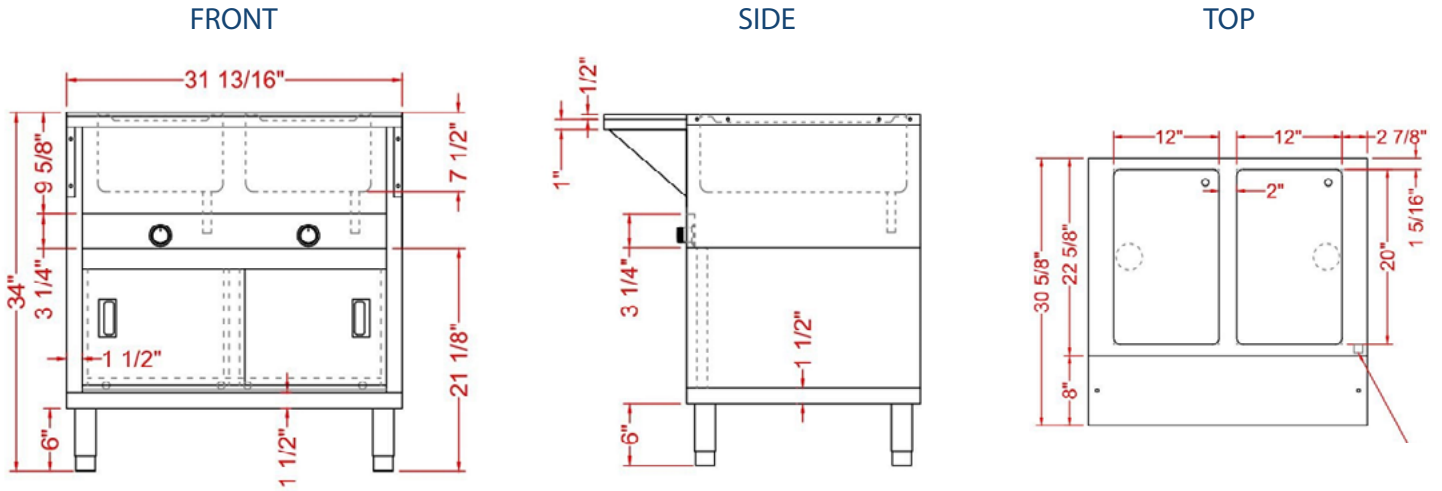

Optional Sneeze Guard

