

Project:	Quantity:
Model #:	Approval:

*For Commercial Use Only*

## Prepline 60" Four Well Electric Hot Food Steam Table with Undershef - 110V, 2000W



### FEATURES

- Removable 1/2" thick poly cutting board
- Stainless steel construction
- Stainless steel heating element
- Undershef included
- 110V, NEMA 5-30P plug type
- Fiberglass insulation between wells
- Adjustable stainless steel feet
- Independent heat controls
- No plumbing or drain needed
- Open well design for water (spillage pans sold separately) or dry heat

- Cabinet assembly required

• cETLus  
• ETL-Sanitation  
Certified to NSF Standard



## Angled Sneeze Guard



- Sneeze guard installation required

- 60" Angled Sneeze Guard
- Heavy Duty Stainless Steel Frame
- Acrylic Shield
- Prevents Contamination

Protect your food while still allowing your customers to see your product! Stainless steel frame and acrylic shield will protect your merchandise on 3 sides.

**U**SR Brands is a US supplier of premium quality commercial cooking, refrigeration and food preparation equipment. Our aim is simple. Produce industry-leading commercial restaurant equipment at reasonable prices, and back it all up with an easy to understand, no nonsense warranty that people can count on.

**TECHNICAL DATA**

MODEL	Exterior Dimension	Number of Well(s)	Electrical	Plug Type	Power	Well Type	Body Type
EST60-4O-110	60" x 30.6" x 34.4"	4	110v/60hz/1ph	NEMA 5-30P	2000w	Open Well	Undershef

**TECHNICAL DRAWING**

SKU: EST60-4O-110  
MFR ITEM #:



FRONT

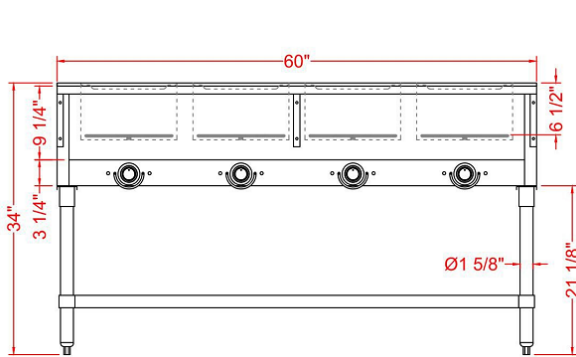

SIDE

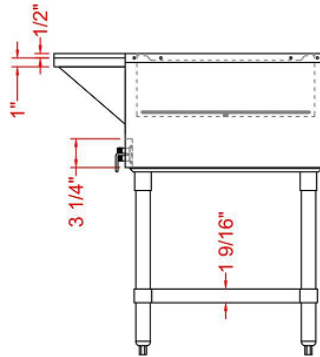

TOP

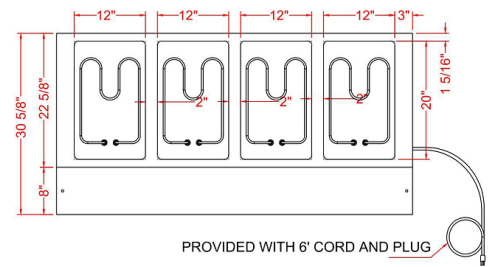

**Angled Sneeze Guard**

FRONT

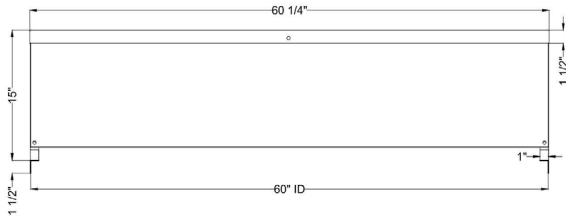

SIDE

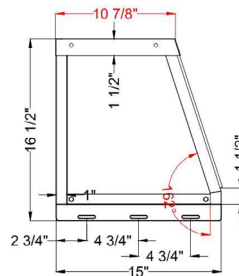

TOP

