



ITEM NO. _____
 PROJECT _____
 LOCATION _____
 DATE _____ QTY. _____

ADVANTEDGE™ NLSMP SERIES

Mega Top Sandwich/Salad Prep Tables

MODELS

- NLSMP27-12 NLSMP60-24
 NLSMP36-15 NLSMP72-30
 NLSMP48-18



NLSMP48-18



FEATURES

CONSTRUCTION

- Stainless steel interior and exterior
- Foamed-in-place with low ODP polyurethane insulation
- Standard 9-1/2" deep reversible cutting board
- Insulated top lid
- Wall thickness: 2"
- 6" overall height casters
- Adjustable heavy-duty shelves
- Field reversible door on NLSMP27-12
- 1/6 size pans included
- Pan adapter bars run front-to-back and side-to-side allowing mixed pan sizes to fit menu requirements
- Pan adapter bars lock together to hold pans in place

DOORS

- Self-closing
- Standard door swing configuration:
 - 1-door models: hinged right
 - 2-door models: left hinged left, right hinged right
 - 3-door models: left hinged left, middle hinged left, right hinged right
- Door width:
 - NLSMP27-12: 27-3/8"
 - NLSMP36-15: 18"
 - NLSMP48-18: 24"
 - NLSMP60-24: 30"
 - NLSMP72-30: 24"

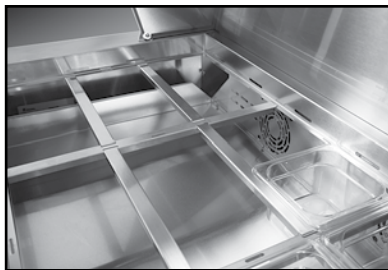

Standard drop-in section:

- Fans force cold air into this enclosed area keeping stored food items consistently cold
- A stainless steel divider prevents food spillage into the storage area beneath
- Accommodates 6" deep pans (4" standard)

OPTIONS

- 6" legs in lieu of casters (legs shipped loose)
 4" casters in lieu of 6" casters (casters shipped loose)
 Additional shelves
 Single or double overshelf



REFRIGERATION

- Self-contained refrigeration system
- Forced air system
- Coated evaporator coil
- Condensate is collected and automatically evaporated from an energy efficient vaporizer
- Refrigerant: R290
- Temperature range: 34° to 38°F (1° to 3°C) for storage area; 33° to 41°F (1° to 5°C) for refrigerated pan well

WARRANTY

- Standard limited three year parts and labor
- Additional two year coverage on compressor part



ADVANTEDGE™ NLSMP SERIES
MEGA TOP SANDWICH/SALAD PREP TABLES

TECHNICAL SPECIFICATIONS

Models	NLSMP27-12	NLSMP36-15	NLSMP48-18	NLSMP60-24	NLSMP72-30
Crated Weight (lbs) (kg)	176 (80)	216 (98)	265 (120)	300 (136)	353 (160)
Crated Height (in) (mm)	45-7/8 (1165)	45-7/8 (1165)	45-7/8 (1165)	45-7/8 (1165)	45-7/8 (1165)
Crated Width (in) (mm)	30-1/8 (765)	38 (965)	51-1/4 (1302)	63 (1600)	74-3/8 (1889)
Crated Depth (in) (mm)	35-7/8 (911)	35-7/8 (911)	35-7/8 (911)	35-7/8 (911)	35-7/8 (911)
Interior Height (in) (mm)	20 (508)	20 (508)	20 (508)	20 (508)	20 (508)
Interior Width (in) (mm)	23-5/8 (600)	32-1/2 (826)	44-5/8 (1133)	56-5/8 (1438)	68-5/8 (1743)
Interior Depth (in) (mm)	22 (559)	22 (559)	22 (559)	22 (559)	22 (559)
Overall Height (in) (mm)	44-1/8 (1121)	44-1/8 (1121)	44-1/8 (1121)	44-1/8 (1121)	44-1/8 (1121)
Overall Width (in) (mm)	27-1/2 (699)	36-3/8 (924)	48-1/4 (1226)	60-3/8 (1534)	72-3/8 (1838)
Overall Depth (in) (mm)*	33-1/8 (841)	33-1/8 (841)	33-1/8 (841)	33-1/8 (841)	33-1/8 (841)
Gross Cubage (CuFt) (L)	6.7 (190)	9.1 (258)	12.5 (354)	15.9 (450)	19.2 (544)
Number of 1/6 Pans	12	15	18	24	30
Number of Shelves	1	2	2	2	3
Shelf Area (SqFt) (Sqm)	3.6 (0.33)	5 (0.46)	6.8 (0.63)	8.6 (0.80)	10.5 (0.93)
Number of Casters	4	4	4	4	4
Condensing Unit Size	1/5 HP	1/5 HP	1/5 HP	1/5 HP	1/5 HP
Refrigerant	R290	R290	R290	R290	R290
Electrical Characteristics	115/60/1	115/60/1	115/60/1	115/60/1	115/60/1
NEMA Plug Configuration	5-15P	5-15P	5-15P	5-15P	5-15P
Total Amp Draw	3.5	3.5	3.5	3.5	3.5

*Overall depth not including removable cutting board

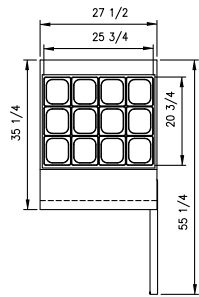

NLSMP27-12 PLAN VIEW

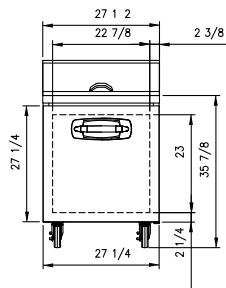

NLSMP27-12 ELEVATION VIEW

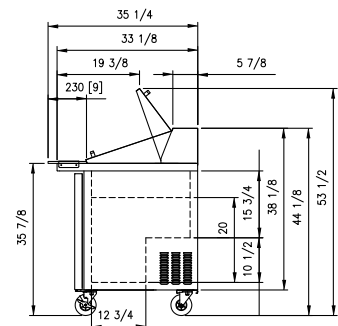

ALL MODELS SIDE VIEW

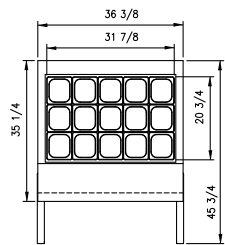

NLSMP36-15 PLAN VIEW

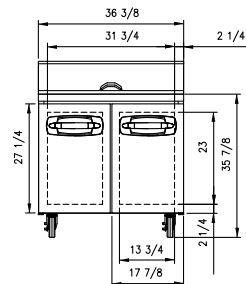

NLSMP36-15 ELEVATION VIEW

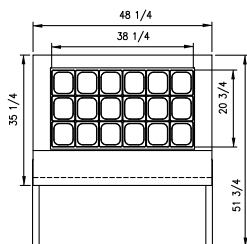

NLSMP48-18 PLAN VIEW

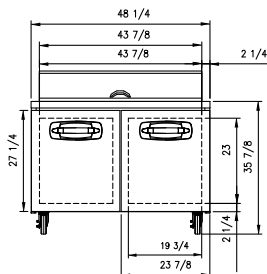

NLSMP48-18 ELEVATION VIEW



ADVANTEDGE™ NLSMP SERIES
MEGA TOP SANDWICH/SALAD PREP TABLES

TECHNICAL SPECIFICATIONS

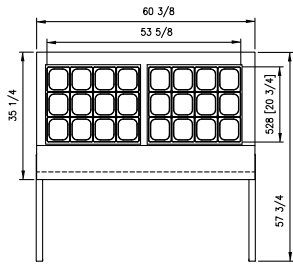

NLSMP60-24 PLAN VIEW

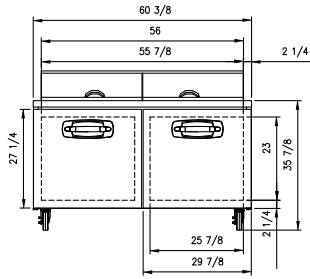

NLSMP60-24 ELEVATION VIEW

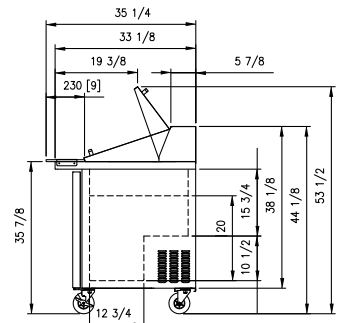

**ALL MODELS
SIDE VIEW**

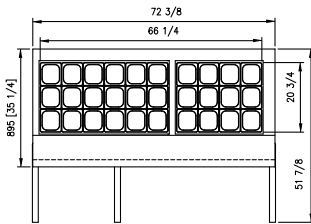

NLSMP72-30 PLAN VIEW

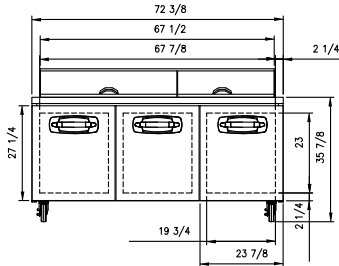

NLSMP72-30 ELEVATION VIEW

OPTIONAL OVERSHELF SPECIFICATIONS

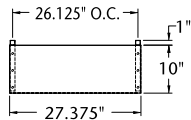

**PLAN VIEW
NLSMP27-8, NLSMP27-12**

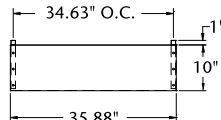

**PLAN VIEW
NLSMP36-10, NLSMP36-15**

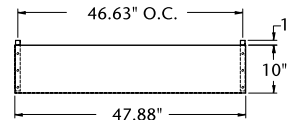

**PLAN VIEW
NLSMP48-12, NLSMP48-18**

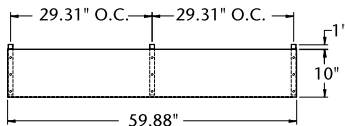

**PLAN VIEW
NLSMP60-16, NLSMP60-24**

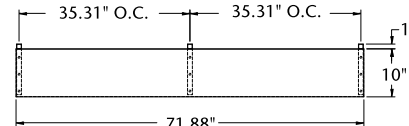

**PLAN VIEW
NLSMP72-18, NLSMP72-30**

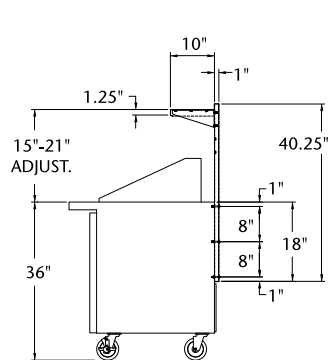

**SINGLE SHELF
SIDE VIEW**

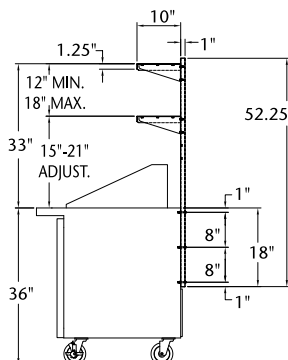

**DOUBLE SHELF
SIDE VIEW**



ADVANTEDGE™ NLSMP SERIES
MEGA TOP SANDWICH/SALAD PREP TABLES

LISTINGS



HOOKUP

All models via plug in, 9 foot long flexible three wire 14/3 cord with molded plug.



BID SPECIFICATIONS

Item no. NLSMP _____.

Provide _____ Mega Top Sandwich/Salad Prep Table(s), Norlake model no. NLSMP _____.

Prep table will feature stainless steel construction on interior and exterior and will be equipped with locking pan adapter bars allowing mixed sized pans.

Prep table will also feature an

enclosed drop-in section to keep food items consistently cold. This section will contain a stainless steel divider to prevent food spillage into the storage area beneath. Section will accommodate up to 6" deep pans (4" standard).

The refrigeration system will be bottom mounted and self-contained. Refrigerant will be R290. The

temperature range will be 34° to 38°F (1° to 3°C) for storage area; 33° to 41°F (1° to 5°C) for refrigerated pan well.

Prep unit to have standard limited three year parts and labor with additional two year coverage on compressor part.

Prep unit will be UL & C-UL listed and ETL Sanitation classified.

NOTE: Cabinet designed for optimum performance in air-conditioned area at 75°F ambient and 55% relative humidity. All specifications within this publication subject to change without notice.

