

Project:	Quantity:
Model #:	Approval:

*For Commercial Use Only*

### Marchia USTAR60G 60" Black Low Profile Open Air Cooler Grab and Go

#### FEATURES

- Brilliant internal LED illumination on sides
- Digital temperature controller and display
- (4) casters with (2) brakes
- 60" black horizontal air curtain merchandiser
- Foamed with CFC-free polyurethane insulation
- Includes energy-saving night cover
- Stainless steel interior standard
- Eco-Friendly R290 refrigerant
- Two-step stainless steel shelf included
- Automatic defrost

The Marchia self service display case is a valuable addition to your deli shop, sandwich shop, bakery, cafe, or other foodservice establishment. Our refrigerated bakery display case is a reliable and durable solution for displaying your hot selling treats to increase impulse sales in your business.



- cETLus Listed
  - ETL Sanitation listed
- Conforms to NSF/CSA Standard



**U**SR Brands is a US supplier of premium quality commercial cooking, refrigeration and food preparation equipment. Our aim is simple. Produce industry-leading commercial restaurant equipment at reasonable prices, and back it all up with an easy to understand, no nonsense warranty that people can count on.

Project:	Quantity:
Model #:	Approval:

For Commercial Use Only

### TECHNICAL DATA

#### DIMENSIONS

Exterior Dimensions	59"L x 33.2"D x 46"H
Interior Dimensions	55.91"L x 23.3"D x 17.9"H
Packaging Dimensions	50.2"L x 36.2"D x 50.9"H
Net Volume	13.3 cu. ft.
Unit Weight	368 lb.
Shipping Weight	505 lb.

#### ELECTRICAL

Voltage	110
Hertz	60
Phase	1
Amps	12.9
Watts	1300
Plug Type	NEMA 5-20P
Power Cord Length	92"

#### COOLING

Temperature Range	35.6°F to 50°F
Refrigerant	R290
Defrosting	Automatic
Temperature Controller	Digital
Horsepower	3/4

#### CONSTRUCTION

Interior Material	Stainless Steel
Shelf Quantity	1 (two-step stainless steel)
Adjustable Shelf	Yes
Features	L.E.D Lighting Night Curtain
Mobility Wheels/Casters	(4) Qty: 2 with brakes, 2 without

### DIAGRAM

MODEL: USTAR60G

MFR MODEL:

FRONT VIEW

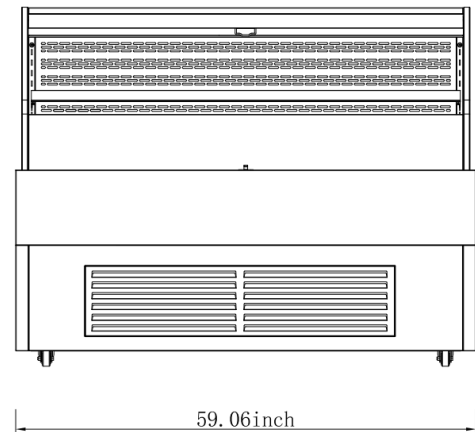

SIDE VIEW

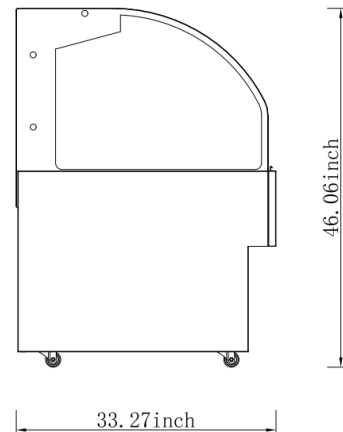

BACK VIEW

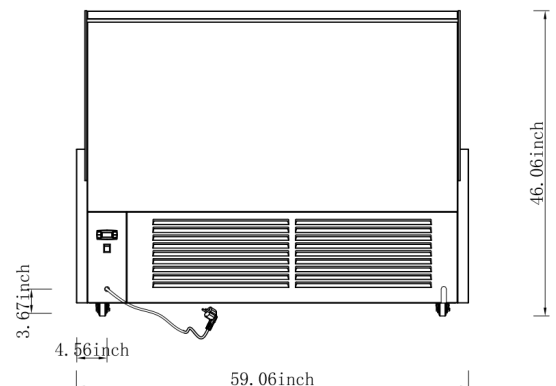

- Designed to operate in locations not exceeding 75°F and 55% relative humidity.