

Project:	Quantity:
Model #:	Approval:

For Commercial Use Only

Marchia MHW65 24" Full-Service Slanted Countertop Heated Display Merchandiser - 2 Shelf



FEATURES

- 24" black countertop heated display merchandiser
- Slanted 2-shelf full-service design
- Tempered glass sides
- Independent heat and light controls for each shelf
- Adjustable thermostat
- 86-194 degrees Fahrenheit temperature range
- Adjustable divider rods
- Fixed rubber feet
- Front and rear openings

- ETL Listed
 - ETL Sanitation Listed
- Conforms to UL & NSF Standard



USR Brands is a US supplier of premium quality commercial cooking, refrigeration and food preparation equipment. Our aim is simple. Produce industry-leading commercial restaurant equipment at reasonable prices, and back it all up with an easy to understand, no nonsense warranty that people can count on.

Project:	Quantity:
Model #:	Approval:

For Commercial Use Only

TECHNICAL DATA

DIMENSIONS

Exterior Dimensions	23.62"L x 27.68"D x 27.72"H
Packaging Dimensions	26.2"L x 30.2"D x 28.9"H
Unit Weight	91 lb.
Shipping Weight	97 lb.

ELECTRICAL

Voltage	110
Hertz	60
Phase	1
Amps	7.8
Wattage	1100
Plug Type	NEMA 5-15P
Power Cord Length	92"

HEATING

Temperature Range	86°F to 194°F
Temperature Controller	Analog / Thermostatic

CONSTRUCTION

Exterior Material	Glass and Stainless Steel
Shelf Quantity	2
Shelf Material	Stainless Steel
Shelf Size	22.05"L x 22.05"D
Interior Light	Yes
Access Type	Front and Rear

TECHNICAL DRAWING

MODEL: **MHW65**

MFR ITEM #: HW-65



NEMA 5-15P

FRONT VIEW

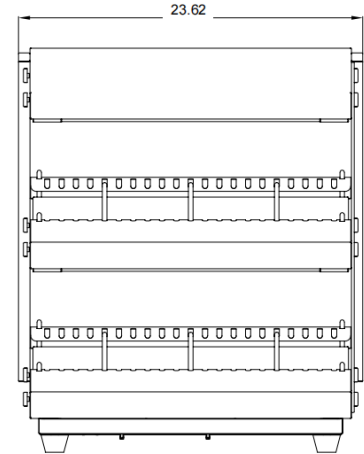

SIDE VIEW

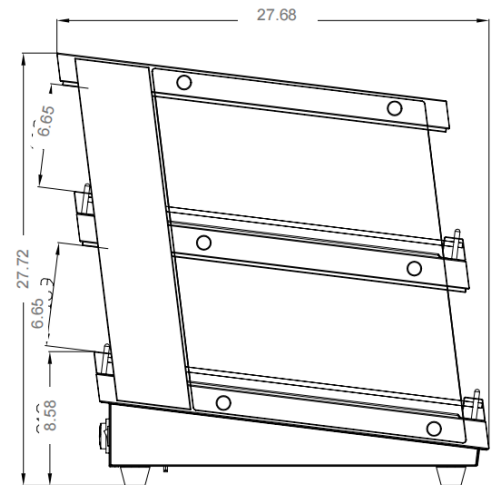

BACK VIEW

