

Project:	Quantity:
Model #:	Approval:

*For Commercial Use Only*

### Marchia MHW102 38" Full-Service Slanted Countertop Heated Display Merchandiser - 2 Shelf



## FEATURES

- 38" black countertop heated display merchandiser
- Slanted 2-shelf full-service design
- Tempered glass sides
- Independent heat and light controls for each shelf
- Adjustable thermostat
- 86-194 degrees Fahrenheit temperature range
- Adjustable divider rods
- Fixed rubber feet
- Front and rear openings

- ETL Listed
  - ETL Sanitation Listed
- Conforms to UL & NSF Standard



**U**SR Brands is a US supplier of premium quality commercial cooking, refrigeration and food preparation equipment. Our aim is simple. Produce industry-leading commercial restaurant equipment at reasonable prices, and back it all up with an easy to understand, no nonsense warranty that people can count on.

Project:	Quantity:
Model #:	Approval:

For Commercial Use Only

## TECHNICAL DATA

### DIMENSIONS

Exterior Dimensions	37.52"L x 27.68"D x 27.72"H
Packaging Dimensions	40.1"L x 30.2"D x 28.9"H
Unit Weight	108 lb.
Shipping Weight	115 lb.

### ELECTRICAL

Voltage	110
Hertz	60
Phase	1
Amps	9.6
Wattage	1100
Plug Type	NEMA 5-15P
Power Cord Length	92"

### HEATING

Temperature Range	86°F to 194°F
Temperature Controller	Analog / Thermostatic

### CONSTRUCTION

Exterior Material	Glass and Stainless Steel
Shelf Quantity	2
Shelf Material	Stainless Steel
Shelf Size	36"L x 22.05"D
Interior Light	Yes
Access Type	Front and Rear

## TECHNICAL DRAWING

MODEL: **MHW102**

MFR ITEM #: HW-102



NEMA 5-15P

FRONT VIEW

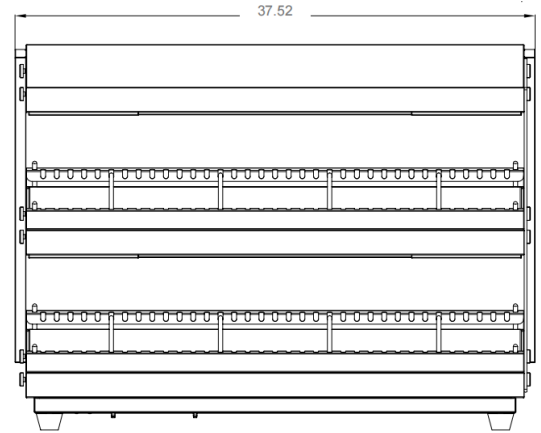

SIDE VIEW

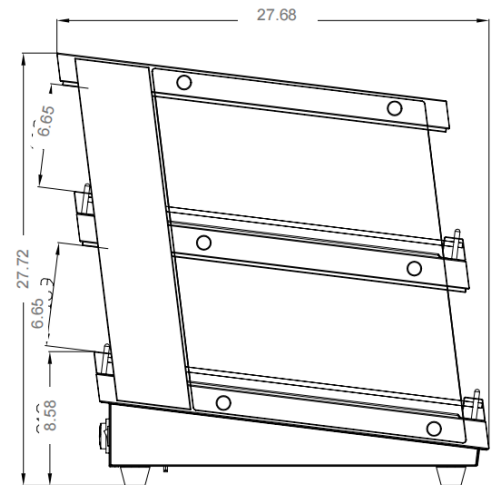

BACK VIEW

