

**LUBCR Series, Lift Up High Volume Curved Glass
Refrigerated Bakery Display Case**

**LUBCD Series, Lift Up High Volume Curved Glass
Dry Bakery Display Case**



model shown LUBCR-77



7453 Northwest 32nd Avenue, Miami, Florida 33147 • (305) 691-0500
Fax (305) 691-1212
www.marcrefrigeration.com



LUBC Series, Lift Up Curved Glass Bakery Display Cases for High Volume Refrigerated and Non-Refrigerated

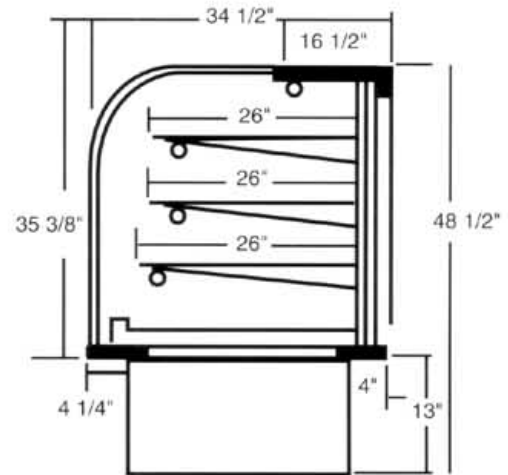

STANDARD FEATURES

- Lift up front glass
- Curved insulated safety glass (non insulated on LUBCD Models)
- Full length fluorescent lighting installed at top of case and under each shelf
- Three rows of heavy duty white coated wire shelves able to accommodate standard 18" x 26" sheet pans
- Electrical cord and plug
- Air cooled low velocity refrigeration system mounted on easy removable slide in and out base on LUBCR Models
- Mirror interior ends
- Mirror interior sliding doors, white on exterior doors
- Mirror stainless top
- Mirror stainless steel front grill on LUBCR Models
- Heavy duty aluminum mill finish main deck on all Models
- Condensate evaporator eliminates need for drain on Refrigerated Models

model	length	height	depth	row of shelves	pan capacity 18" x 26"	amps	voltage	H.P.	est. weight
LUBCR-48	49 1/2"	48 1/2"	34 1/2"	3	8 full 4 half	12 amps	120/60/1	1/3	665 lbs
LUBCD-48	49 1/2"	48 1/2"	34 1/2"	3	8 full 4 half	3 amps	120/60/1	—	470 lbs
LUBCR-59	60 1/2"	48 1/2"	34 1/2"	3	12	16 amps	120/60/1	1/2	780 lbs
LUBCD-59	60 1/2"	48 1/2"	34 1/2"	3	12	3 amps	120/60/1	—	680 lbs
LUBCR-77	78 1/2"	48 1/2"	34 1/2"	3	16	16 amps	120/60/1	1/2	970 lbs
LUBCD-77	78 1/2"	48 1/2"	34 1/2"	3	16	3 amps	120/60/1	—	840 lbs

NOTE: Designed for use in locations with air conditioning, where temperature and relative humidity DO NOT exceed 75°F and 55% R.H. (Excessive condensation & loss of temperature may occur).

We reserve the right to change specifications and or colors of interior and or exterior parts at our own discretion without notice.

