

ICE BIN KB-350

Durable Design

- Created to endure the every day use of your commercial environment
- High quality construction to insure reliability, longevity and product durability
- 4" adjustable stainless steel feet included (can be adjusted to a height of 6" high)

Energy Efficiency

- High density urethane insulation reduces the ice melting inside the bin

Superior Quality

- Designed for efficiency and dependability
- Stainless steel exterior for superior resilience to rust and easy to clean
- Ergonomic door design
- Capacity: 353 lb / 160 kgs
- Dimensions (W x D x H in inches)
Cabinet: 30" x 34.30" x 38.10"
Shipping: 31.30" x 35.45" x 44.80"
- Weight (lb / kgs)
Net : 120 lb / 54 kgs
Shipping: 132 lb / 60 kgs



Can be used with KCM-450-AH, KCM-450-AH-22 (adapter required-not included), KCM-670-AH, KCM-1100-AH

Warranty: 2 years parts and labor

Valid in United States, Canada & Puerto Rico.
Please contact factory for warranty in other countries.



AUTODESK
REVIT®



Intertek

ISO 9001
CERTIFIED

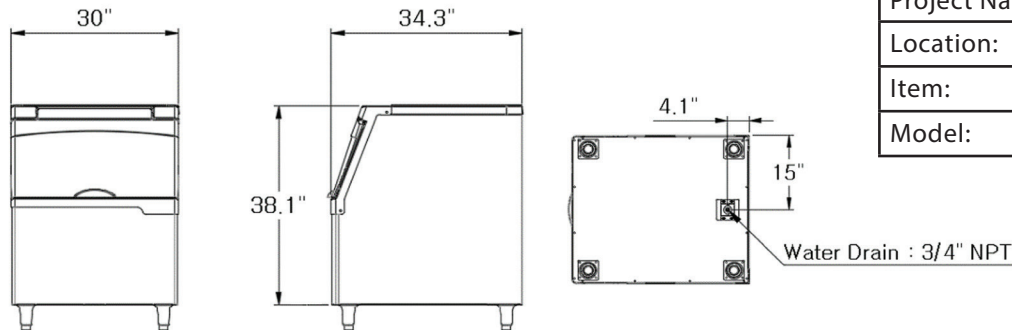

Project Name:	
Location:	
Item:	Qty:
Model:	



5659 Royalmount Ave.
Montreal, QC, Canada H4P 2P9
Telephone: 514.737.9701 / Toll Free: 888.275.4538
Fax: 514.342.3854 / Toll Free: 877.453.8832
sales@mvpgroupcorp.com / mvpgroupcorp.com

12000 Biscayne Blvd., Suite # 108
Miami, FL, United States 33181
Telephone: 786.600.4687 / Toll Free: 844.218.8477
Fax: 786.661.4100