

Model Numbers  
ISPA-18-E  
ISPA-18-2-E



Dual controls, inner and outer coils are controlled independently.



Infinite heat controls for maximum cooking flexibility.

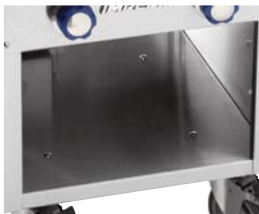

Stainless steel open cabinet base.



ISPA-18-E shown with optional casters

#### DUAL COIL ELEMENT - High temperature dual coil element.

- Dual controls, inner and outer coils are controlled independently.
- Infinite heat controls for maximum cooking flexibility.
- Element is 13" (330 mm) diameter for maximum pan contact.

#### EXTERIOR FEATURES - Stainless steel top, front and sides with welded and finished seams.

- Stainless steel cabinet base for storage.
- Knobs are cast aluminum with Valox™ heat protection grip.
- Heavy duty legs with adjustable feet.
- One year parts and labor warranty.

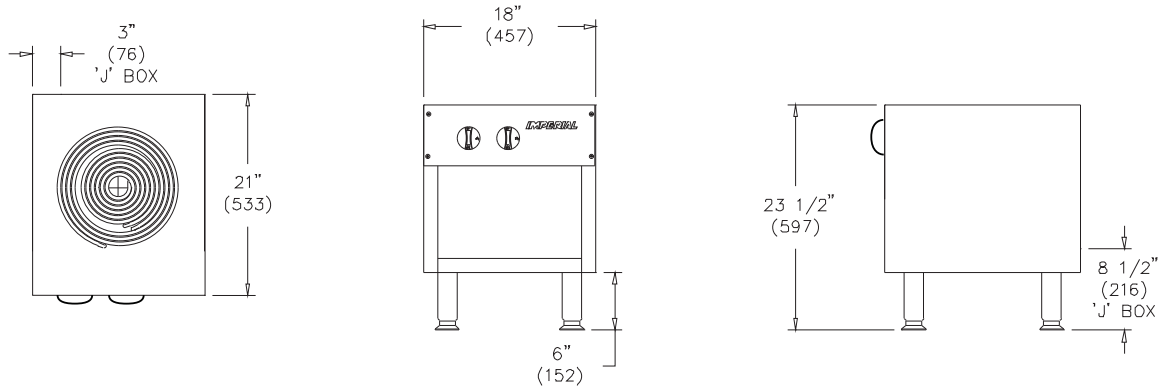

**ELECTRIC STOCK POT RANGE**

MODEL	ELEMENT DESCRIPTION	TOP SIZE		SHIP WEIGHT	
		IN	(MM)	(KG)	LBS
ISPA-18-E	13" (330) Dual Coil	18" x 21"	(457 x 533 mm)	(36)	79
ISPA-18-2-E	2 13" (330) Dual Coil	18" x 42"	(457 x 1067 mm)	(72)	158

Measurements in ( ) are metric equivalents.

	ELECTRICAL REQUIREMENT			
	KW	VOLTS	PHASE	AMPS
ISPA-18-E	6 KW	208	3	22
	8 KW	240	3	29
ISPA-18-2-E	12 KW	208	3	44
	16 KW	240	3	58

MODEL	DIMENSIONS	CRATED DIMENSIONS
ISPA-18-E	18" w x 21" d x 23-1/2" h (457 x 533 x 597 mm)	20-1/2" w x 23-1/2" d x 22" h (521 x 597 x 559 mm)
ISPA-18-2-E	18" w x 42" d x 23-1/2" h (457 x 1067 x 597 mm)	20-1/2" w x 46" d x 22" h (521 x 1168 x 559 mm)

**CLEARANCE REQUIREMENTS**

For use only on non-combustible floors with legs or casters. 0" clearance from non-combustible side and rear walls. Provide 6" (152 mm) minimum clearance from combustible side walls and 0" from combustible wall at rear.

**OPTIONS AND ACCESSORIES**

- 18" (457 mm) height available (specify 18" H when ordering)
- Side-by-side range orientation in lieu of front-to-back (available at an additional charge)
- 6" (152 mm) casters, set of 4, 2 with brakes
- 6" (152 mm) casters, set of 6, 3 with brakes

