



UNDER COUNTER REFRIGERATORS



› FEATURES

- CFC free refrigerant and foam insulation
- Electronic thermostat and digital LED temperature display for accurate control and easy reading
- Easy to mount 2.5" casters (lockable in front) are standard with all units
- Self-closing doors that remain open at 90 degrees
- Magnetic gasket can be replaced without any tools
- Adjustable, heavy-duty epoxy coated wire shelves (one per door)
- Stainless steel framework construction
- Auto defrosting and auto evaporation of condensation water
- Exterior: 430 stainless steel, door & front panel: 202 stainless steel
- Interior: side panel: ABS plastic, bottom: 304 stainless steel, balance in aluminum
- Temperature: 33 to 41°F / 0.5 to 5°C
- Electrical: 115/60/1 with NEMA 5-15P plug

› SPECIFICATIONS

MODEL	DOORS	EXT. DIMENSIONS W x D x H (in)	INT. DIMENSIONS W x D x H (in)	AMPS	H.P.	SHIP WEIGHT
KUC27 *	1	27.8 x 29.9 x 35.5	23.0 x 24.9 x 24.2	5	3/8	199 lbs
KUC48 *	2	48.2 x 29.9 x 35.5	43.5 x 24.9 x 24.2	5	3/8	280 lbs
KUC60 *	2	61.2 x 29.9 x 35.5	56.5 x 24.9 x 24.2	5	3/8	331 lbs
KUC72	3	71.7 x 29.9 x 35.5	67.0 x 24.9 x 24.2	5	1/2	380 lbs

› OPTIONS - DRAWERS **

KUC27-2D • KUC48-2D • KUC48-4D • KUC60-2D • KUC60-4D

See page 34 for pan configurations for units with drawers.

**Available by custom order only. Please contact our Sales Department for availability and lead time.

CERTIFIED TO ANSI/NSF-7 STANDARDS



Head Office : 5659 Royalmount Ave., Montreal, Qc, Canada H4P 2P9
TEL: (514) 737-9701 • TOLL FREE: (888) 275-4538
FAX: (514) 342-3854 • TOLL FREE FAX: (877) 453-8832

US Sales Office : 12000 Biscayne Blvd, Suite 108, Miami, FL 33181
TEL: (786) 600-4687 • TOLL FREE: (844) 218-8477 • FAX: (786) 661-4100
mvpgroupcorp.com • sales@mvpgroupcorp.com



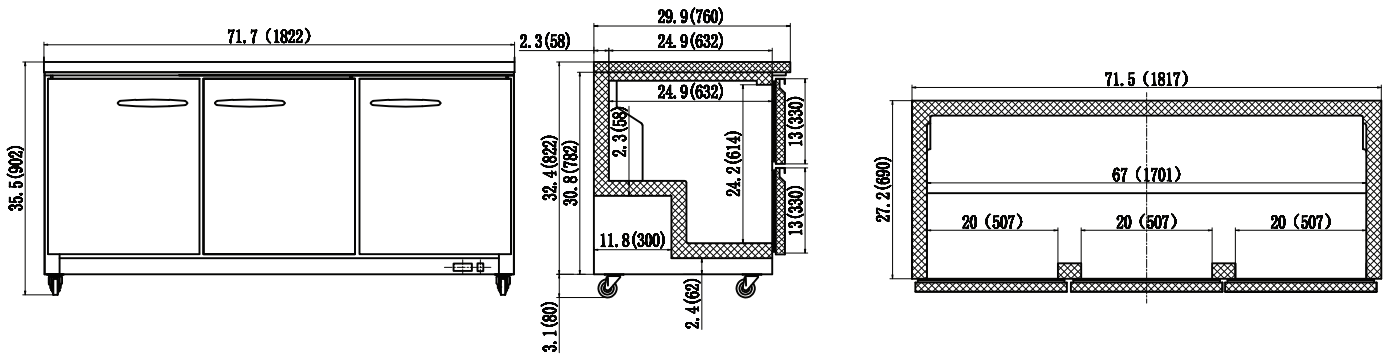
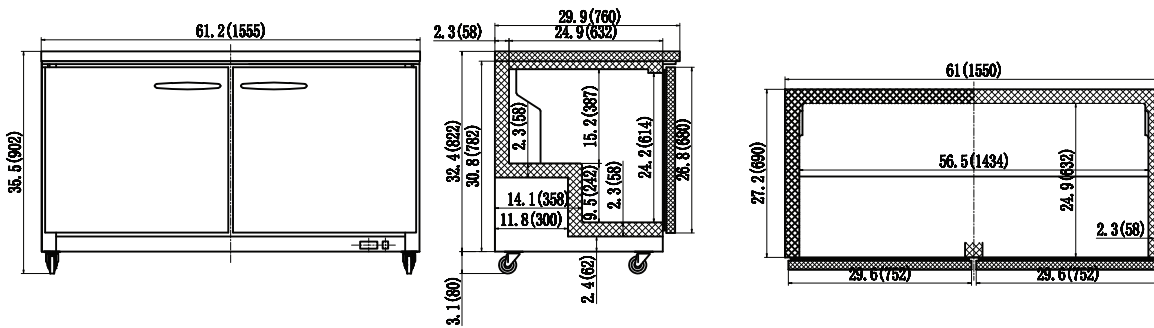
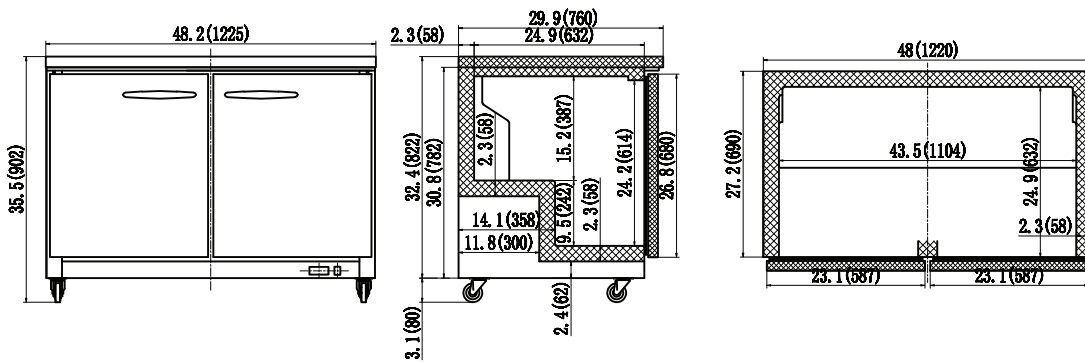
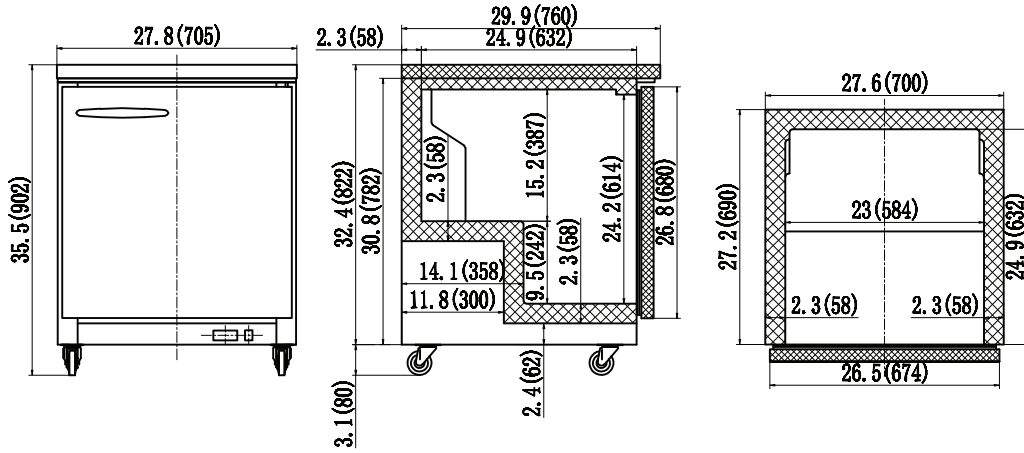

Dimensions in inches (mm)