

Dual-Temp Islands HKI-DT Series



MODELS

HKI-DT-60-S
HKI-DT-80-S
HKI-DT-100-S

Features

- Created to endure the everyday promotion of frozen & all refrigerated items, ideal to display frozen seafoods, meats and other frozen foods
- Dual temperature island cabinet switches temperatures with the push of a button
- Dual temperature / dual control, operators can adjust according to the demand
- Four sides of tempered glass
- Stainless steel 201 bumper guards on all sides
- Available in three lengths: 60 in, 80 in and 100 in.
- DOE compliant
- Ventilated cooling for optimum performance
- Hot gas pipe for automatic condensate water
- Environmentally friendly R290 refrigerant
- EMBRACO compressor, high cooling efficiency, 220V- 60Hz. must be hard wired
- Auto condensate system for evaporation, convenient to use
- Polyurethane cavity integral foaming process thereby reducing cold energy consumption
- Ultra-thin oversized high-performance evaporator, delivers fast cooling, and effective volume
- Designed for total mobility with casters as standard equipped with 4 swivels
- Entirely self-contained system
- Temperature Range: -10°F to 42°F

MODEL NUMBER	HKI-DT-60-S	HKI-DT-80-S	HKI-DT-100-S
Gross Capacity (Cu Ft.)	11.2	15.2	18.9
Net Capacity (Cu Ft.)	7.6	10.2	12.8
Display Area (Sq Ft.)	18.7	27.2	35.6
Temperature Range (°C)	Freezer: from -10°F to 42°F Refrigerator: from 35°F to 46°F	Freezer: from -10°F to 42°F Refrigerator: from 35°F to 46°F	Freezer: from -10°F to 42°F Refrigerator: from 35°F to 46°F
Voltage	220V-60Hz	220V-60Hz	220V-60Hz
Rated Power (W)	During freezing: 1412 During defrosting: 3900	During freezing: 1593 During defrosting: 4100	During freezing: 1735 During defrosting: 4700
Rated Current (A)	During freezing: 6.8 During defrosting: 18.5	During freezing: 7.8 During defrosting: 19.2	During freezing: 8.3 During defrosting: 21.3
Refrigerant (g)	R290/2*90	R290/2*120	R290/2*130
Compressor / HP	2PCS EMBRACO NEU2178U / 1HP	2PCS EMBRACO NEU2178U / 1HP	2PCS EMBRACO NEU2178U / 1HP
Net Weight (lbs)	584	705	950
Product Dimensions (In)	62.4" x 41.2" x 40"	82.1" x 41.2" x 40.5"	102.2" x 41.7" x 40"
Packing Dimensions (In)	69.1" x 47" x 49.5"	869" x 47" x 49.5"	110" x 49" x 49.5"

HKI-DT-60-S

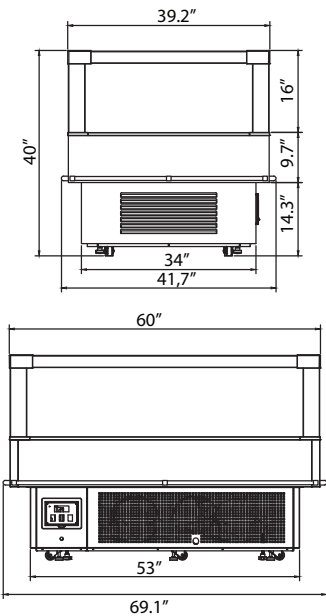

HKI-DT-80-S

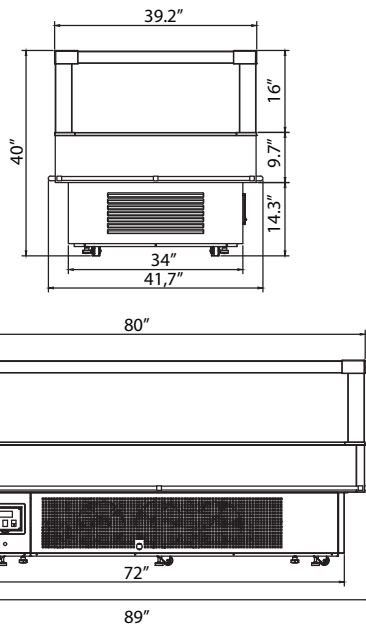

HKI-DT-100-S

