



Item No. _____

VRL3B1A

Self-Contained Reach-In, Bottom Mount
Low Temperature Merchandiser

Advanced Design

- Contemporary styling places maximum attention on merchandising
- Self-closing Innovator doors. Positive seal, torsion type closure system

Merchandising with Style

- Interior LED vertical lighting – 4 columns
- Illuminated Exterior Flat Sign Panel

Smart Construction

- Frame rail fitted with leg levelers
- Controller with communication ability via MODBUS
- UL/ETL, NSF Type II and DOE 2017 certified

Innovative Refrigeration

- Environmentally-friendly R290 hydrocarbon refrigerant that has zero ozone depletion potential and 3 GWP

Options

- Stainless steel exterior/interior.
- Baskets, peg bar and hooks.
- Additional display shelves available.
- Price tag molding and sign kit available.
- Door locks, and shelf product stops.
- Alternate electrical plug configurations available.
- Left glass door opening standard. Other options available.
- Solid fascia available
- Various exterior colors, black or white interior
- Mullion (premium) lights
- Leveler leg
- Casters
- Seismic restraint kits

AIA #



Hussmann Corporation

12999 St. Charles Rock Rd.
Bridgeton, MO 63044-2483
Ph: 800.592.2060
www.hussmann.com

VRL3B1A

Self-Contained Reach-In, Bottom Mount Low Temperature Merchandiser

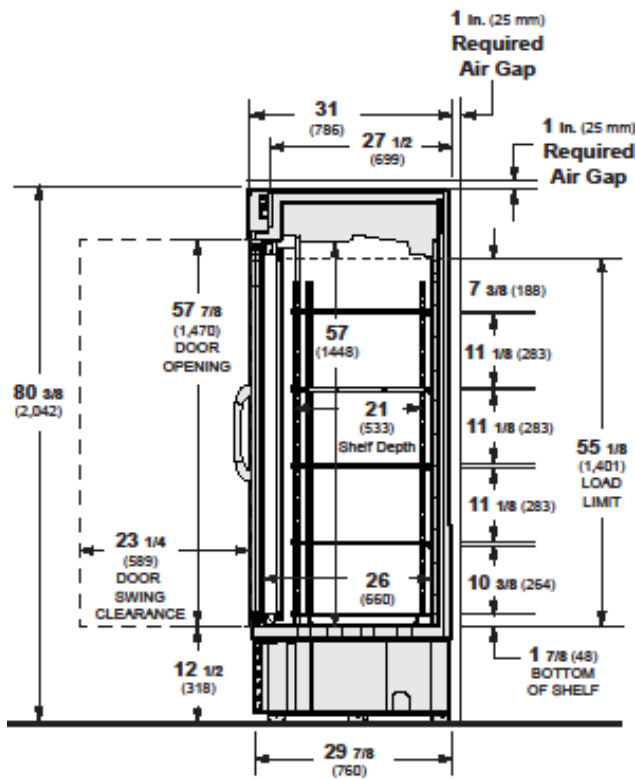

Side View

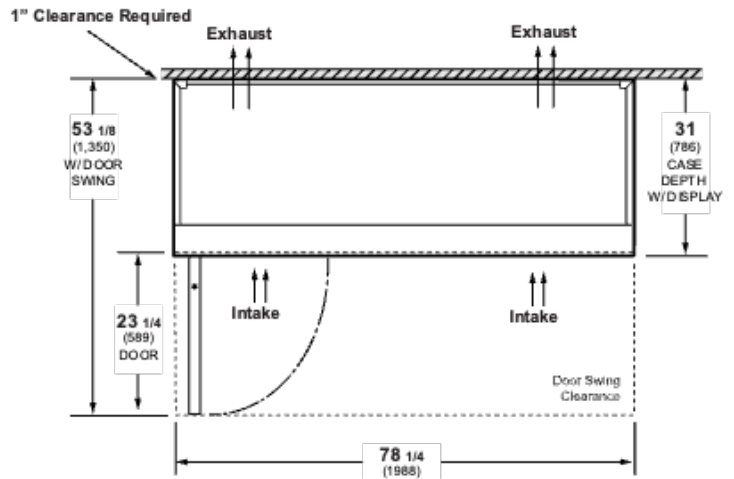

Plan View

Dimensions are shown as in. and (mm)

A clearance of 36 inches is needed in front of the case to ensure no obstruction in the condensing unit air flow.

1 inch clearance required at the top and rear of the case.

Zero clearance is required on the sides of the case.

Model	Doors	L (int)	D	H	Cu/ft Capacity	Ref.	Volts	Run Amps	Noise	Cord Length	Weight
		L (ext)	D*	H**							
VRL3B	3	74.38" (1889 cm)	23.72" (704 cm)	55.16" (857 cm)	66.1	R-290	120 60/1	9.5	64.8 dB	9 ft. (2.74m)	877 lbs (398 kg)
		78.25" (1987 cm)	31.25" (704 cm)	80.37" (857 cm)							

*Excludes door handles; **Includes leveling pods

Notes:



NEMA 5-20P



[More Info](#)

For more detailed information scan or click above.

We reserve the right to change or revise specifications and product design in connection with any feature of our products. Such changes do not entitle the buyer to corresponding changes, improvements, additions, or replacements for equipment previously sold or shipped. For additional resources, contact your representative or visit www.husmann.com.

HUSSMANN[®]
FOOD SERVICE

12999 St. Charles Rock Rd.
Bridgeton, MO 63044-2483
Ph: 800.592.2060

www.husmann.com

AIA #