



EUF27A/48A

One and Two Section Full Stainless Undercounter Freezer

EUF27A/48A
10/30/20
Item # 13569

W x D x H

27" x 30" x 33.75"
(including 4" casters)

W x D x H

47.75" x 30" x 33.75"
(including 4" casters)

Item #: _____
 Project: _____
 Qty: _____
 AIA#: _____



Features

- Engineered to maintain NSF-7 temperatures of 100° ambient
- Stainless steel exterior front, sides, and top
- Front breathing air flow design
- Environmentally friendly R290 hydrocarbon refrigerant
- Spring assisted self-closing doors with stay open feature
- Stainless steel exterior door(s)
- Field reversible doors
- Stainless steel interior floor with aluminum sides, rear, and top
- Heavy duty grey epoxy coated shelves are adjustable in 1/2" increments; 1 per section. 105 lbs. capacity
- Aluminum shelf supports are adjustable in 1/2" increments
- Standard with 4" casters (two with brakes)
- 9 ft. cord and plug
- Container Qty:
EUR27A: 88
EUR48A: 46



Dimensions / Capacity

	One Section EUF27A	Two Section EUF48A
Interior Storage Capacity (CF) (AHAM)	6.33 ft ³	12.09 ft ³
Overall Width x Depth	27" x 31.25"	47.75" x 31.25"
Height (including 4" casters)	33.75"	33.75"
Door Opening (W x H)	22.6" x 22.75"	19.5" x 22.75"
Depth with Door Open at 90°	55.75"	52.75"
Adjustable Shelves	1	2
Shelf Dimensions (W x D)	22" x 16"	21.25" x 16"
Crated Shipping Weight	200 lbs.	290 lbs.
Crated Length x Depth x Height	33" x 29" x 37"	52" x 33" x 37"

Electrical / Refrigeration

	One Section EUF27A	Two Section EUF48A
Voltage	115/60/1	115/60/1
HACR Breaker	15.0 Amps	15.0 Amps
Electrical Connection (NEMA)	5-15P Ⓢ	5-15P Ⓢ
Voltage Range	115-127	115-127
Ambient Temp. Range	45° to 100°F	45° to 100°F
Control Setpoint Range	-5° to 5°F	-5° to 5°F
Amperage	1.2	1.7
Energy Consumption (kWh/day) @ASHRAE	1.92	3.44
Approx. Nominal Compres. BTU/HR (HP)	993(1/5)	1468(1/3)
Refrigerant / Charge Amount (oz.)	R290 / (1.9oz)	R290 / (2.3oz)

Options

Warranty

* 2 Year - Parts and Labor on entire machine.
 5 Year - Parts on Compressor
 Valid in United States, Canada, Puerto Rico and U.S. Territories. Contact factory for warranty in other countries.



EUF27A/48A

One and Two Section Full Stainless Undercounter Freezer

EUF27A/48A
10/30/20
Item # 13569

FRONT VIEW

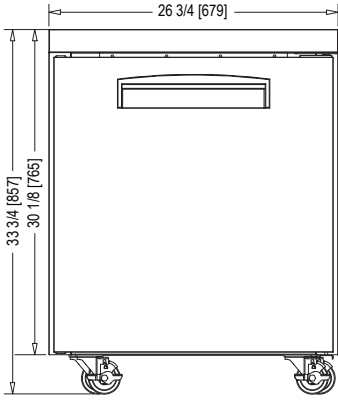

EUF27A

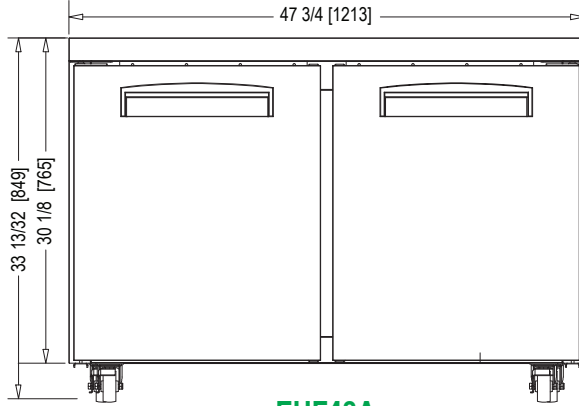

EUF48A

SIDE VIEW

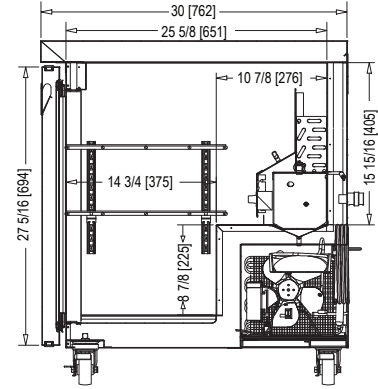

EUF27A

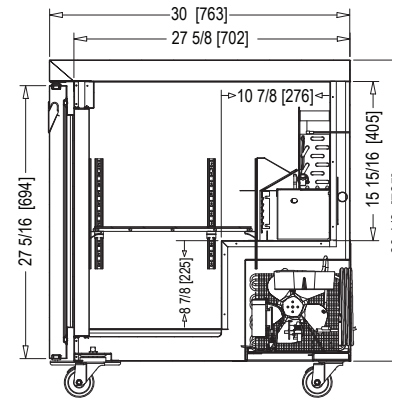

EUF48A

PLAN VIEW

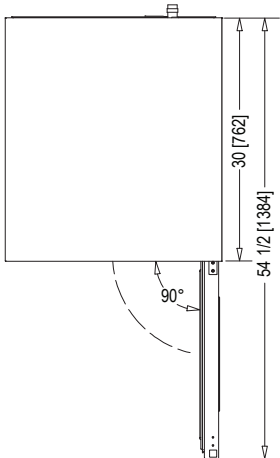

EUF27A

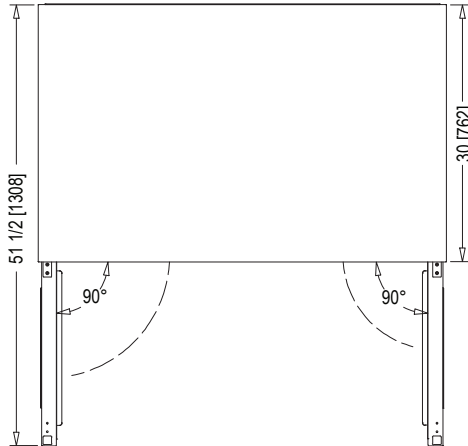

EUF48A

REAR VIEW

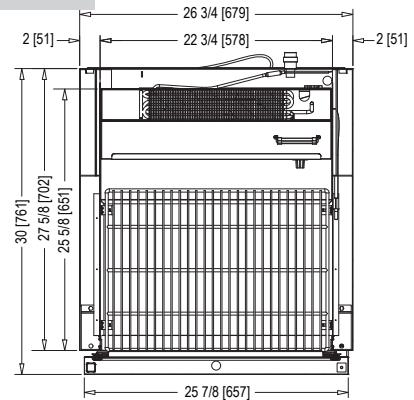

EUF27A

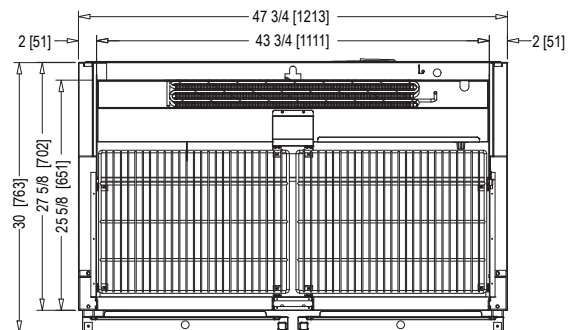

EUF48A