



USER MANUAL

MANUAL PALLET JACK



MODEL: JACK-4N, JACK-4S



USR Brands, Inc.

Phone: 800-764-1172 | www.usrestaurant.com | sales@usrestaurant.com

USRESTAURANT® RESERVES THE RIGHT TO CHANGE SPECIFICATIONS WITHOUT NOTICE

Contents

1. Operation Manual
 - 1.1 Range of Application
 - 1.2 Operating Instruction
 - 1.3 Safety Precautions
2. Description of truck
 - 2.1 Applied Range
 - 2.2 Illustration of Assembly Units & Operating Conditions
3. Using Functions
 - 3.1 Test Run
 - 3.2 Control Handle Knob Adjustment
 - 3.3 Safe Parking
4. Safe Operation
 - 4.1 Inspection of Hydraulic Oil
 - 4.2 Air Extraction
 - 4.3 Daily Maintenance
 - 4.4 Possible Faults and trouble shooting

1. Operation Manual

1.1 Range of Application

Truck should be operated, used and maintained in accordance with this manual. Other operation, which are not listed in this manual, may cause hazards to people and truck, and may lead to property loss. Please carefully read the nameplate first to make sure the loading weight doesn't exceed the truck's capacity. Overload and unbalanced load should be avoided. Flammable explosive environment may cause explosion.

1.2 Operating Instruction

The truck can only be operated by staff who has been trained well, has obtained a diver license, knows how to deal with loading, is clear about the operating instructions and has grasped operating skills. All the users should carefully read and understand the content of this manual.

Failure to comply with the instructions will result in losing warranty. These rules apply equally to products that have been unlawfully exported without manufacturer's permission by customers (or third party).

1.3 Safety Precautions

User should be responsible to the truck's useful life. It is forbidden to load people and let them stand on the forks to side. When discover damage and other flaw, user should immediately send report to supervisor.

2 Description of truck

2.1 Applied Range

The truck can lift and carry goods on level ground by using fork. It can also carry open type tray and transverse tray. User can obtain the carrying capacity from the truck's nameplate.

2.2 Illustration of Assembly Units & Operating Conditions

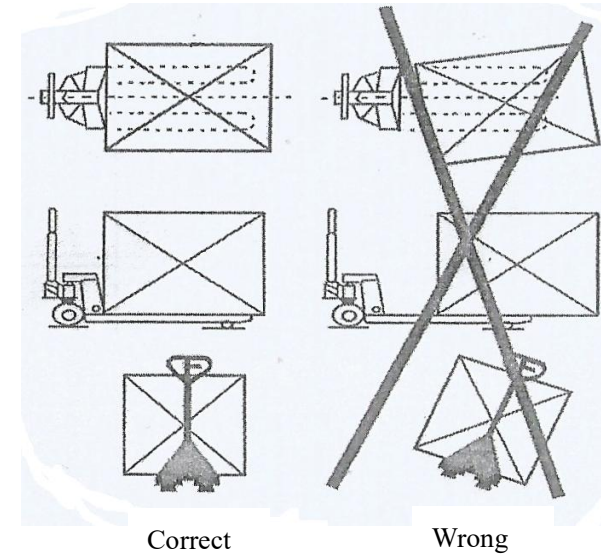
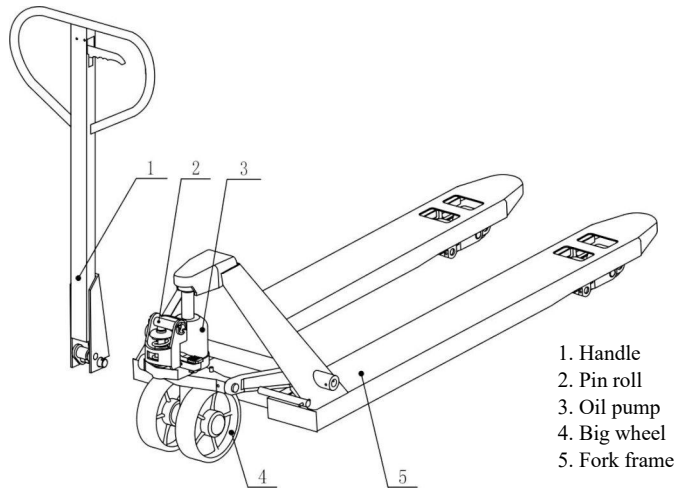

3. Using Functions

3.1 Test Run

Loading goods at test run should be operated in the safe area with staff only. The gravity center of the goods should be positioned in the middle of the two forks. Do not put goods at rear of the fork. The carrying capacity can be maximized when weight is evenly distributed.

3.2 Control Handle Knob Adjustment

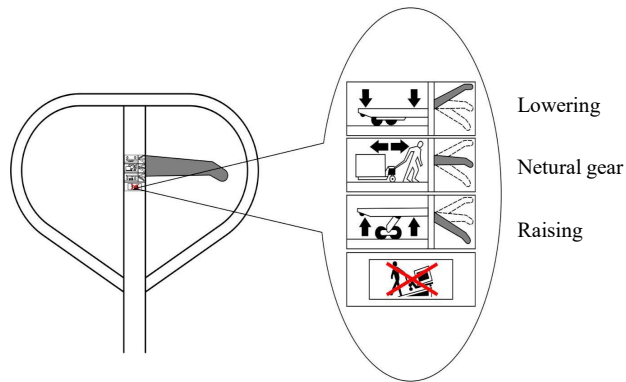

The control handle knob has three positions (up, middle, down).

Up Push the control handle knob to the lower position, then bob up and down the handle to lift goods on fork.

Middle Keep the forklift in the middle position, then the fork will not lift or decent. This mode is used to pull the truck.

Down Pull and keep the control handle knob to the upper position, then the fork will descend. Release the control handle knob, it will automatically get back to the middle position.

Lift Make sure the fork is fully into the bottom of the goods before lifting the goods. When everything ready, push the control handle knob to the lower position and rock the handle to lift goods to the wanted height.

Descend When pull the control handle knob up, the fork will descend. Release the control handle knob, it will automatically get back to the middle position, and the fork will stop descend. When moving truck, the control handle knob should be kept in the middle position.

3.3 Safe Parking

Do not park the truck on an inclined plane. The truck forks should be on the lowest position while parking. Wheels should be fixed and fencing should be used to protect the truck when using other vehicle to transport it.

4. Safe Operation

4.1 Inspection of Hydraulic Oil

Check the oil mass every six months. The total capacity is about 0.3 L. Hydraulic oil type: L-HV46. Use under $-20^{\circ}\text{C} \sim +40^{\circ}\text{C}$.

4.2 Air Extraction

Air will easily get into the oil tank because of transportation and inversion. This will lead to the failure of lifting the fork when push the control handle knob to the lower position. Method of air extraction: Pull and keep the control handle knob to the upper position, then rock the handle for several times.

4.3 Daily Maintenance

Daily maintenance can improve the truck's service life. Specially pay attention to the place between wheels and axis. Make sure there is no yarn or other rags in order to keep all wheels running with handiness. When the truck does not work, make sure that the truck forks are on the lowest position.

4.4 Possible Faults and trouble shooting

Use the method listed in the following table (table 4.4). If the fault can not be removed, please contact the supplier for an advanced checking. The maintenance can only be done by specialized persons. Person without specialized training shouldn't assemble and disassemble the truck.

Table 4.4 Possible Faults and trouble shooting

	Fault Description	Reason	Method
1	Fork cannot reach the wanted height	·Lacking of hydraulic oil.	·Add hydraulic oil.
2	Fork cannot rise	·Hydraulic oil is not pure. ·The relief valve is opened because the adjustment nut is too high or the screw is too close. ·Air in the hydraulic oil.	·Change hydraulic oil. ·Readjust the position of the adjustment nut or the adjustment screw. ·Bob up and down the handle to extract the air.
3	Fork cannot descend	·The large piston or the pump body is damaged because of the unevenly distributed weight on the fork or overloading. ·The fork has been kept in high position for a long time, and the large piston is rusted. ·The adjustment nut or the adjustment screw is in an incorrect position.	·Change the large piston or the pump body. ·Keep the fork in the minimum height when work is done. Pay attention to lubricate the piston lever. ·Readjust the position of the adjustment nut or the adjustment screw.
4	Oil leak	·Aging or damaging of sealing element. ·Some elements are crazed.	·Change the damaged elements.
5	Fork descend without operation	·The relief valve cannot shut because of impure hydraulic oil. ·Some of the hydraulic system elements are damaged or crazed. ·Air in the hydraulic oil. ·Aging or damaging of sealing element. ·The adjustment nut or the adjustment screw is in an incorrect position.	·Change hydraulic oil. ·Check and change the damaged elements. ·Extract thee air. ·Change the sealing elements. ·Readjust the position of the adjustment nut or the adjustment screw.