

HOT WATER DISPENSER

HWB Series

HWB-15

15 Gallon



The **HWB-15** 15 gallon hot water dispenser is the ideal size for medium-to-heavy duty food/beverage prep and cleaning tasks. Set the thermostat at the desired temperature for consistent and precise hot water dispensing for a variety of foods such as gravy, oatmeal, mashed potatoes, cheese sauce, gelatins & much more.



The green "Ready Light" indicator illuminates when hot water is ready to dispense at your preprogrammed temperature.



Protective faucet guard provides an additional level of sanitation by reducing cross-contamination from various sized containers.



The interior top and sides of the unit are fully insulated to maximize heat retention and improve efficiency.

Water Specification

Water Inlet 3/8 inch male flare fitting	Minimum Flow Rate 3/4 gpm [2.8 lpm]	Water Pressure 20-75 psig [137-517 kPa]
--	--	--

Electrical Configuration

Configuration Code	Heater Configuration	Voltage	Phase	Wires	KW	Electrical Connection	Max Amp Draw	Gallon[Liter]/Hour
US & CANADA								
H15011	2 x 3.0 kW	120/208-240	1	3+G	4.6-6.1	Terminal Block	22.0-25.4	11.0-15.0 [41.6-56.7] ⁽¹⁾
H15021 ⁽²⁾	3 x 3.0 kW	120/208-240	3	4+G	7.0-9.1	Terminal Block	19.4-22.4	17.0-22.0 [64.3-83.2] ⁽¹⁾
EXPORT								
H15041 ⁽²⁾	3 x 3.0 kW	220-240/380-415	3	4+G	7.8-9.1	Terminal Block	11.8-12.9	15.0-19.0 [56.7-71.9] ⁽¹⁾

(1) Based on standard factory settings: 200°F water.
 (2) Requires 3 phase upcharge.

Measurements

Height 29 5/8" [75.2 cm]	Width 20 3/8" [51.1 cm]	Depth 27 3/4" [70.4 cm]	Empty Weight 70 lbs [31.7 kg]	Filled Weight -	Shipping Weight 105 lbs [47.6 kg]	Shipping Dimensions: 33" x 24" x 28" [84 x 61 x 71 cm]
-----------------------------	----------------------------	----------------------------	----------------------------------	--------------------	--------------------------------------	---

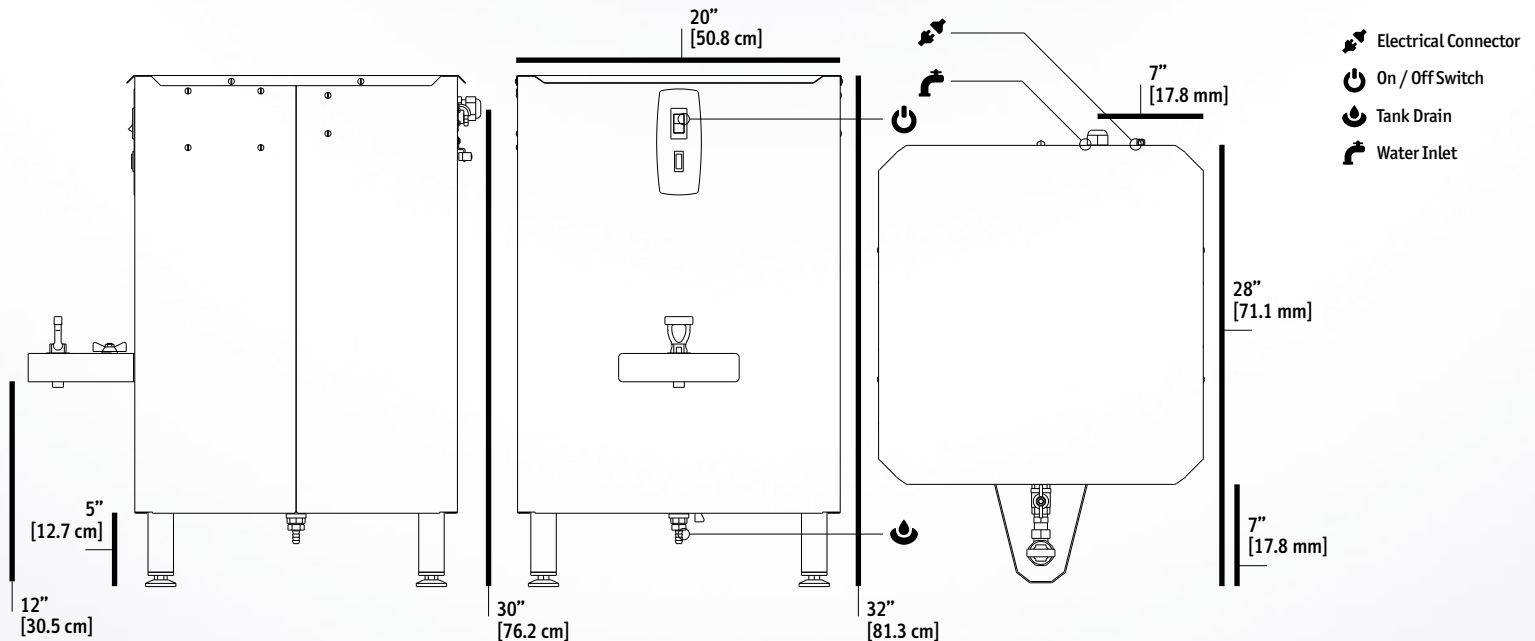

Cups per Hour*

8oz.	356	12oz.	237	16oz.	178	20oz.	142
------	-----	-------	-----	-------	-----	-------	-----

* Approximate based on maximum power setting.

Information

fetco.com

800.338.2699 USA
847.719.3000

847.719.3001

Food Equipment Technologies Co.
600 Rose Road
Lake Zurich, IL 60047
USA