

# DRAWERED UNDERCOUNTER REFRIGERATOR BACK MOUNTED CONDENSING UNIT

Project Name: \_\_\_\_\_

Project Location: \_\_\_\_\_

Model #: \_\_\_\_\_ Quantity: \_\_\_\_\_

Available Warehouse: \_\_\_\_\_

## ETB Series Model: ETBSR2-D2



### Refrigeration System

- Back mounted, self-contained and fully detachable Blizzard R290 condensing unit uses environmentally friendly, EPA-compliant R290 refrigerant with zero (0) Ozone Depletion Potential (ODP) and three (3) Global Warming Potential (GWP). Blizzard R290 is easily replaceable and requires no on-site brazing.
- Front air breathing for flexibility in installation.
- Electronically commutated (ECM) fan motors achieve rapid cooling with less energy consumption.
- Full-length air duct system ensures optimal circulation of cold air.
- Time-initiated and temperature-terminated auto defrost cycle for seamless operation.
- Large capacity, corrosion-resistant condenser and evaporator coils.
- Self-maintaining, energy-efficient condensate drain pan requires no external drains or electric heaters.
- High performance, auto-reverse condenser fan motor supports compressor ventilation and condenser coil cleaning. Refer to owner's manual for full maintenance instructions.
- Pressure relief devices allow smooth access to cabinet interior when reopening doors.
- Pre-wired and ready to plug, 115V/60Hz/1Ph, NEMA 5-15P.

### Cabinet Construction

- Heavy duty stainless steel interior / exterior with rounded corners for a hazard-free workspace.
- Open spaced interior with no walls between compartments.
- 16 gauge, high quality stainless steel worktop.
- Galvanized steel bottom and rear.
- 2.5" thick high density polyurethane insulation.
- Four 5" swivel casters with locks on front set.

### Doors

- Heavy duty stainless steel interior / exterior.
- 2.5" thick high density polyurethane insulation.
- Thick gauge, stainless steel drawer frames with low-friction ball bearings.
- Self-closing door with adjustable torsion system for a positive seal.
- Snap-in magnetic door and drawer gaskets make cleaning and replacement an easy process.
- High strength, recessed door and drawer handles.

### Shelving

- Height adjustable stainless steel clips.

### Temperature Control

- Multi-function digital controller with easy to read LED display.
- Factory preset temperature, 35°F. Temperature setting range from 33°F to 54°F.
- Audible overheat protection alarm for compressor and condenser coil.

### Options

- 4" high stainless steel backsplash for worktop application.
- 3" swivel casters with locks.
- 3.5" – 6" height-adjustable and interchangeable legs.
- NSF Certified Stainless Steel Double Overshelf.

 **Operating temperature range is 33°F ~ 54°F**



**5 YEAR Compressor  
3 YEAR Parts & Labor**



Please visit our website for updated Energy Efficiency information

Ref/ Frz/Dual	Doors	Capacity Cu. Ft.	# of Pans	Shelves	Refrigerant	HP	Power V-Hz-Ph	Amps	Crated Weight	Exterior Dimensions		
										L	D	H*
REF	2(DR)	10	1/2x4, 1/3x2, 1/4x2, 1/6x1	-	R-290	1/5	115-60-1	2.7	235 lbs (107kg)	35.625" (905mm)	31.5" (800mm)	30.125" (765mm)

(†)Based on evaporating temperature of 23°F (-5°C) & condensing temperature of 131°F (55°C). (►) Product capacity is calculated based on standard industry figures. (✳) Reference plan view for clarification on caster/unit height. If dimensions and capacity are critical, please contact Everest Refrigeration. Blizzard R290 replacement is at the sole discretion of Everest Refrigeration. Specifications subject to change without notice.

# DRAWER UNDERCOUNTER REFRIGERATOR BACK MOUNTED CONDENSING UNIT

## ETB Series Model: ETBSR2-D2

### DIMENSIONAL DATA

External Dimensions	L	35.625" (905mm)
	D	31.5" (800mm)
	H*	30.125" (765mm)
Crated Weight		235 lbs. (107kg)
Doors/Drawers/Lids		2(DR)
Max Weight Support (LBS)		-

### STORAGE DATA

Net Capacity Cu. Ft. ▶	10
Shelves	-
Barrels	-
20 oz. Bottles	-
12 oz. Bottles	-
12 oz. Cans	-
8" Mugs	-
# of Pans (Top)	-
# of Pans (Drawer)	1/2x4, 1/3x2, 1/4x2,
Dividers	-
Trays	-

### ELECTRICAL DATA

Voltage	115-60-1
Full Load Amperage	2.7A
Feed Wires with Ground	3
Cord Length	9ft
NEMA Plug Type	 NEMA 5-15P

### REFRIGERATION DATA

Compressor Mounting	Back
Refrigerant	R-290
Compressor HP	1/5
BTU/HR †	1655

### KEY

D	Door	R	Refrigerator
L	Lid	REF	Refrigerator
H	Half Door	F	Freezer
FD	Full Door	FRZ	Freezer
SD	Solid Door	DUAL	REF/FRZ Combo
GD	Glass Door	DR	Drawer

	Elevation	Right	Plan	3D	Back

### PLAN VIEW

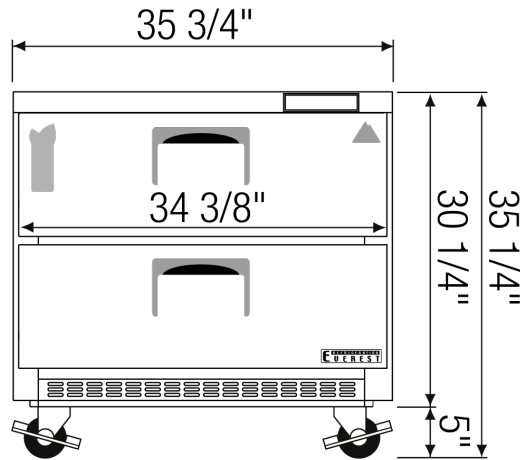

FRONT

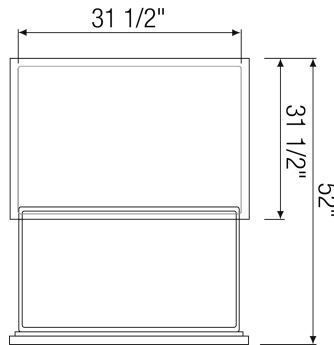

TOP

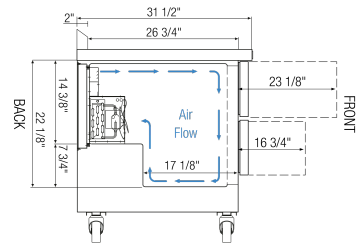

SIDE

### ACCESSORIES & OPTIONS

Part Number	Description
AJL03-00	Interchangeable Leg for Caster
BKSPL01-00	4" High (35-1/2" Long) Backsplash
CASA3-01	3" Overall Height Caster Assembly - (2) Front (2) Rear
OS01-00	Standard Double Overshelf 12" Depth x 36" Length

(†)Based on evaporating temperature of 23°F (-5°C) & condensing temperature of 131°F (55°C). (▶) Product capacity is calculated based on standard industry figures. (✖) Reference plan view for clarification on caster/unit height. If dimensions and capacity are critical, please contact Everest Refrigeration. Blizzard R290 replacement is at the sole discretion of Everest Refrigeration. Specifications subject to change without notice.