

OPEN AIR MERCHANDISERS

VERTICAL · 35" DEEP · TALL

Project Name: _____

Project Location: _____

Model #: _____ Quantity: _____

Available Warehouse: _____

EOMV Series Model: EOMV-48-B-35-T

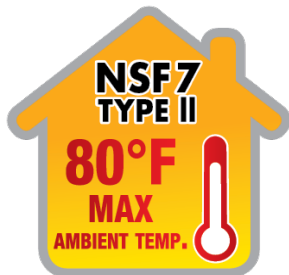

Refrigeration System

- Bottom mounted, self-contained and fully detachable Blizzard R290 condensing unit uses environmentally friendly, EPA-compliant R290 refrigerant with zero (0) Ozone Depletion Potential (ODP) and three (3) Global Warming Potential (GWP). Blizzard R290 is easily replaceable and requires no on-site brazing.
- Front air intake and rear air discharge design allows side by side installation.
- Conforms to **NSF Standard 7 TYPE II (maximum ambient temperature 80°F)**.
- Electronically commutated (ECM) evaporator fan motors achieve rapid cooling with less energy consumption.
- High performance, auto-reverse condenser fan motor supports compressor ventilation and condenser coil cleaning. Refer to owner's manual for full maintenance instructions.
- Large capacity, corrosion-resistant condenser and evaporator coils.
- Self-maintaining, energy-efficient condensate drain pan requires no external drains or electric heaters.
- Pre-wired and ready to plug, 115V/60Hz/1Ph, NEMA 5-20P.

Cabinet Construction

- Black or white modern exterior has moisture-resistant panels and field-replaceable tempered glass.
- Heavy-duty stainless steel interior has perforated back wall for efficient air flow. Includes floor drains for ease of cleaning.
- Galvanized steel top, bottom and rear.
- 2.5" thick high-density polyurethane insulation.
- Integrated retractable night curtain saves energy and provides security.
- 5" swivel casters with locks on front set. Leg stabilizers standard for all models.

Lighting

- Shielded LED bar lighting under shelves and canopy provide bright, high color illumination at lower heat output. On/off switch saves energy

Shelving

- Adjustable by height and angle. Position it flat or slanted downward at 10°.
- Heavy duty stainless steel shelves include price tag moldings.

Temperature Control

- Factory preset temperature of 35°F maintains a combined average product temperature of 40°F or less.
- Audible overheat protection alarm for compressor and condenser coil.

Recommended Operating Conditions

- Conforms to NSF standard 7 TYPE II designed to operate in an air-conditioned environment where temperature and humidity do not exceed 80°F and 55% relative humidity.
- Must not be installed near ventilation systems, fans or exterior doors or windows that will disrupt the air curtain and compromise the function of the cabinet.
- Must not be installed in direct sunlight.
- In built-in applications, a distance of 6" is required on the front, back and top exterior for ventilation purposes.



Please visit our website for updated Energy Efficiency information

| Ref/ Frz/Dual | Capacity Cu. Ft. | Shelves | NEMA Config | Refrigerant | HP | Power V-Hz-Ph | Amps | Crated Weight | Exterior Dimensions | | |
|------------------|---------------------|---------|-------------|-------------|---------|------------------|------|------------------|---------------------|-------------------|-----------------|
| | | | | | | | | | L | D | H* |
| REF | 24 | 4 | NEMA 5-20P | R290 | 3/4 x 2 | 115-60-1 | 14 | - lbs (0kg) | 48" (1219mm) | 34.25" (870mm) | 78" (1981mm) |

(†)Based on evaporating temperature of 23°F (-5°C) & condensing temperature of 131°F (55°C). (►) Product capacity is calculated based on standard industry figures. (✳) Reference plan view for clarification on caster/unit height. If dimensions and capacity are critical, please contact Everest Refrigeration. Blizzard R290 replacement is at the sole discretion of Everest Refrigeration. Specifications subject to change without notice.

OPEN AIR MERCHANDISERS

VERTICAL · 35" DEEP · TALL

EOMV Series Model: EOMV-48-B-35-T

DIMENSIONAL DATA

| | | |
|--------------------------|--------------|----------------|
| External Dimensions | L | 48" (1219mm) |
| | D | 34.25" (870mm) |
| | H* | 78" (1981mm) |
| Crated Weight | - lbs. (0kg) | |
| Doors/Drawers/Lids | - | |
| Max Weight Support (LBS) | - | |

STORAGE DATA

| | |
|------------------------|----|
| Net Capacity Cu. Ft. ▶ | 24 |
| Shelves | 4 |
| Barrels | - |
| 20 oz. Bottles | - |
| 12 oz. Bottles | - |
| 12 oz. Cans | - |
| 8" Mugs | - |
| # of Pans (Top) | - |
| # of Pans (Drawer) | - |
| Dividers | - |
| Trays | - |

ELECTRICAL DATA

| | |
|------------------------|--------------|
| Voltage | 115-60-1 |
| Full Load Amperage | 14A |
| Feed Wires with Ground | 3 |
| Cord Length | 9ft |
| NEMA Plug Type | Ⓜ NEMA 5-20P |

REFRIGERATION DATA

| | |
|---------------------|---------|
| Compressor Mounting | Bottom |
| Refrigerant | R290 |
| Compressor HP | 3/4 x 2 |
| BTU/HR † | - |

KEY

| | | | |
|----|------------|------|---------------|
| D | Door | R | Refrigerator |
| L | Lid | REF | Refrigerator |
| H | Half Door | F | Freezer |
| FD | Full Door | FRZ | Freezer |
| SD | Solid Door | DUAL | REF/FRZ Combo |
| GD | Glass Door | DR | Drawer |

| | | | | | |
|--|-----------|-------|------|----|------|
|  | Elevation | Right | Plan | 3D | Back |
| | | | | | |

PLAN VIEW

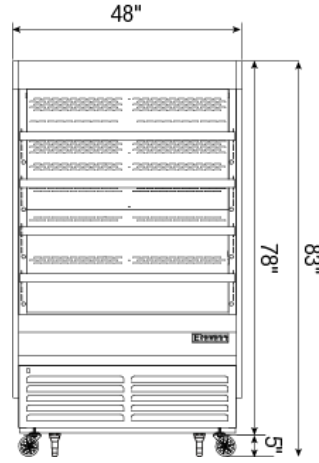

FRONT

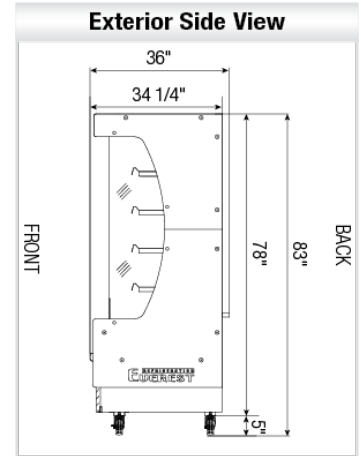

SIDE

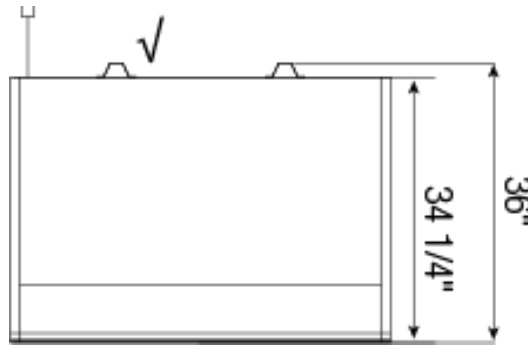

TOP

ACCESSORIES & OPTIONS

| Part Number | Description |
|-------------|-------------|
|-------------|-------------|

(†)Based on evaporating temperature of 23°F (-5°C) & condensing temperature of 131°F (55°C). (▶) Product capacity is calculated based on standard industry figures. (✖) Reference plan view for clarification on caster/unit height. If dimensions and capacity are critical, please contact Everest Refrigeration. Blizzard R290 replacement is at the sole discretion of Everest Refrigeration. Specifications subject to change without notice.