

## SkyLine Pro Natural Gas Boilerless Combi Oven 101 120V

ITEM # \_\_\_\_\_

MODEL # \_\_\_\_\_

NAME # \_\_\_\_\_

SIS # \_\_\_\_\_

AIA # \_\_\_\_\_



**219962 (ECOG101C200)** SKYLINE Pro DIGITAL OVEN 10 HALF SHEET PANS (13" X 18") OR 10 HOTEL PANS (12" X 20")- GAS 120V -BOILERLESS

---

### Short Form Specification

**Item No.** \_\_\_\_\_

Combi oven with high resolution full touch screen interface, multilanguage, IPX5, ETL, EnergyStar, Ergocert

- BOILERLESS
- OptiFlow: air distribution system with 5 fan speed levels
- SkyClean: Automatic and built-in self cleaning system with integrated descale of the steam generator.
- 2 Cooking modes: Programs, Manual
- automatic backup mode to avoid downtime
- USB port to download HACCP data, programs and settings. Connectivity to the cloud ready
- Single sensor core temperature probe
- Double-glass door with double LED lights line
- Retractable hand-shower
- Includes (5) 922062 stainless steel grids

### Main Features

- Digital screen: interface with LED backlight buttons with guided selection.
- Instant steam generator: Boilerless steaming function to add and retain moisture for high quality, consistent cooking results. Automatic moistener (11 settings)
- Dry, hot convection cycle (77 °F - 575 °F/25°C - 300 °C): ideal for convection cooking.
- EcoDelta cooking: cooking with food probe maintaining preset temperature difference between the core of the food and the cooking chamber.
- Programs mode: up to 100 recipes can be stored in the oven's memory, to recreate the exact same recipe at any time. 4-step cooking programs also available.
- Reversible Fan: 5 speed fan levels from 300 to 1500 RPM with reverse rotation for optimal evenness. Fan stops in less than 5 seconds when door is opened.
- Single sensor core temperature probe included.
- Automatic cool-down and pre-heat function
- SkyClean: Automatic self cleaning system with integrated descaling of the steam boiler. 5 automatic cycles (soft, medium, strong, extra strong, rinse-only) and green functions to save energy, water, detergent and rinse aid. Also programmable with delayed start.
- Different chemical options available: solid (phosphate-free), liquid (requires optional accessory).
- GreaseOut: predisposed for integrated grease drain and collection for safer operations (dedicated base as optional accessory).
- USB port: to download HACCP data, share cooking programs and configurations. USB port also allows to plug-in sous-vide probe (optional accessory).
- Back-up mode: self-diagnosis is automatically activated if a failure occurs to avoid downtime.
- Capacity: 10 half sheet/hotel pans.
- OptiFlow air distribution system to achieve maximum performance in chilling/heating evenness and temperature control thanks to a special design of the chamber.

### Construction

- Double thermo-glazed door with open frame construction, for cool outside door panel. Swing hinged easy-release inner glass on door for easy cleaning.
- Seamless hygienic internal chamber with all rounded corners for easy cleaning.
- 304 AISI stainless steel construction throughout.
- Front access to control board for easy service.
- IPX 5 spray water protection certification for easy cleaning.
- Supplied with 6 tray rack for hotel pans, 2 2/3" pitch (67 mm).

### User Interface & Data Management

- Connectivity: ready for real time access to connected appliances from remote and HACCP monitoring (requires optional accessory).

APPROVAL: \_\_\_\_\_





### Sustainability

- Human centered design: with 4-star certification for ergonomics and usability.
- Door handle: ergonomic wing-shaped design for hands-free door opening with elbow, to allow simple trays management (Registered Design at EPO).

### Included Accessories

- 5 of Single 304 stainless steel grid (12" x 20") PNC 922062

### Optional Accessories

- Caster kit for base for 61, 62, 101 and 102 oven bases only PNC 922003
- Pair of half size oven racks, type 304 stainless steel PNC 922017
- Chicken racks, pair (2) (fits 8 chickens per rack) PNC 922036
- Single 304 stainless steel grid (12" x 20") PNC 922062
- Stainless steel 304 grids (GN ½) with spikes, fits 4 chickens PNC 922086
- External side spray unit PNC 922171
- Baguette tray, made of perforated aluminum, silicon coated, 16" x 24" PNC 922189
- Perforated baking tray, made of perforated aluminum, 16" x 24" PNC 922190
- Baking tray, made of aluminum 16" x 24" PNC 922191
- Pair of frying baskets PNC 922239
- Pastry grid 16" x 24" PNC 922264
- Double-click closing catch for oven door PNC 922265
- Grid for whole chicken 1/1GN (8 per grid - 2.6 lbs each) PNC 922266
- Grease collection tray (4") for 61 and 101 ovens PNC 922321
- Kit universal skewer rack & (4) long skewer ovens (TANDOOR) PNC 922324
- Universal skewer pan for ovens (TANDOOR) PNC 922326
- Skewers for ovens, (4) 24" long (TANDOOR) PNC 922327
- Multipurpose hook PNC 922348
- 4 FLANGED FEET FOR 61,62,101,102 OVENS - 2" 100-130MM PNC 922351
- Grid for 8 whole ducks (1.8KG, 4LBS) - GN 1/1 PNC 922362
- Thermal blanket for 101 oven (trolley not included) PNC 922364
- HOLDER FOR DETERGENT TANK - WALL MOUNTED PNC 922386
- USB SINGLE POINT PROBE PNC 922390
- 10 Tray Rack with wheels, Half Sheet Pans, 2 ½" (65mm) pitch for 101 ovens and blast chillers PNC 922601
- 8 Tray Rack with wheels, Half Sheet Pans, 3" (80mm) pitch, for 101 ovens and blast chillers PNC 922602
- Bakery/pastry tray rack with wheels holding 400x600mm grids for 10 GN 1/1 oven and blast chiller freezer, 80mm pitch (8 runners) PNC 922608

- Slide-in rack with handle for 61 and 101 combi oven PNC 922610
- Open base with tray support for 61 & 101 combi oven PNC 922612
- Cupboard base with tray support for 61 & 101 combi oven PNC 922614
- HOT CUPBOARD BASE WITH TRAY SUPPORT FOR 61 AND 101 OVEN HALF SHEET PANS (12" X 20") PNC 922615
- External connection kit for detergent and rinse aid PNC 922618
- Grease collection kit for 61,62,101,102 cupboard base (trolley with 2 tanks, open/close device and drain) PNC 922619
- Stacking kit for gas 61 combi oven placed on gas 101 combi oven PNC 922623
- Trolley for slide-in rack for 61 and 101 combi oven and blast chiller freezer PNC 922626
- Trolley for mobile rack for 61 on 61 or 101 combi ovens PNC 922630
- Stainless steel drain kit for all oven sizes (61, 62, 101,102, 201,202)- dia=50mm (2") PNC 922636
- Plastic drain kit for all oven sizes (61, 62, 101,102,201, 202), dia=50mm (2") PNC 922637
- Grease collection kit for open base (2 tanks, open/close device and drain) PNC 922639
- Wall support for 101 oven PNC 922645
- Banquet rack with wheels holding 30 plates for 101 oven and blast chiller freezer, 65mm pitch (2 1/2") PNC 922648
- Banquet rack with wheels 23 plates for 101 oven and blast chiller freezer, 85mm pitch PNC 922649
- Dehydration tray, (12" x 20"), H=2/3" PNC 922651
- Flat dehydration tray, (12" x 20") PNC 922652
- Bakery/pastry rack kit for 10 GN 1/1 oven with 8 racks 400x600mm and 80mm pitch PNC 922656
- Heat shield for stacked ovens 61 on 101 combi ovens PNC 922661
- Heat shield for 101 combi oven PNC 922663
- Kit to convert from natural gas to LPG PNC 922670
- Kit to convert from LPG to natural gas PNC 922671
- Flue condenser for gas oven PNC 922678
- Fixed tray rack for 10 GN 1/1 and 400x600mm grids PNC 922685
- Kit to fix oven to the wall PNC 922687
- Tray support for 61 & 101 oven base PNC 922690
- 4 adjustable feet with black cover for 61,62 & 101,102 combi ovens, 150-200mm (5 9/10in -7 9/10in) PNC 922693
- Reinforced tray rack with wheels, lowest support dedicated to a grease collection tray for 101 oven pitch: 2 1/2" PNC 922694
- Detergent tank holder for open base PNC 922699
- Bakery/pastry runners 400x600mm for 6 & 10 GN 1/1 oven base PNC 922702
- Wheels for stacked ovens PNC 922704
- Spit for lamb or suckling pig (up to 26lbs) for 61,101,201 PNC 922709
- Mesh grilling grid (12" x 20") PNC 922713
- Probe holder for liquids PNC 922714



- Fixed tray rack, 101 combi oven, h= h=85mm (3 1/3") PNC 922741
- Fixed tray rack, 102 combi oven, h= h=85mm (3 1/3") PNC 922742
- 4 high adjustable feet for 61,62 & 101,102 combi ovens, 230-290mm (9in - 11 2/5in) PNC 922745
- Tray for traditional static cooking, H=100mm (12' x 20") PNC 922746
- Double-face griddle, one side ribbed and one side smooth, 400x600mm PNC 922747
- TROLLEY FOR GREASE COLLECTION KIT PNC 922752
- WATER INLET PRESSURE REDUCER PNC 922773
- Extension for condensation tube, 37cm PNC 922776
- Non-stick universal pan (12" x 20" x 3/4") PNC 925000
- Non-stick universal pan (12" x 20" x 1 1/2") PNC 925001
- Non-stick universal pan (12" x 20" x 2 1/2") PNC 925002
- Frying griddle double sided (ribbed/ smooth) 12" x 20" PNC 925003
- Aluminum combi oven grill (12" x 20") PNC 925004
- Egg fryer for 8 eggs (12" X 20") PNC 925005
- Flat baking tray with 2 edges (12" x 20") PNC 925006
- Baking tray for (4) baguettes (12" x 20") PNC 925007
- Potato baker GN 1/1 for 28 potatoes (12"X20") PNC 925008
- Non-stick U-pan (12" x 10" x 3/4") PNC 925009
- Non-stick U-pan (12" x 10" x 1 1/2") PNC 925010
- Non-stick U-pan (12" x 10" x 2 1/2") PNC 925011
- Compatibility kit for installation on previous base 61,101 PNC 930217

Front

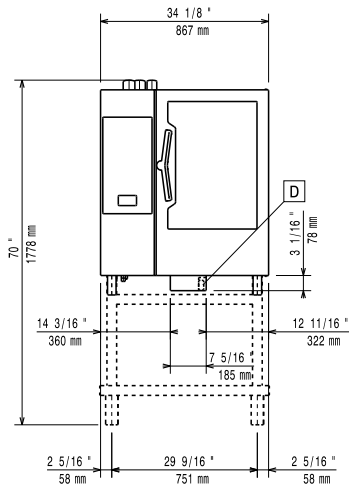

Side

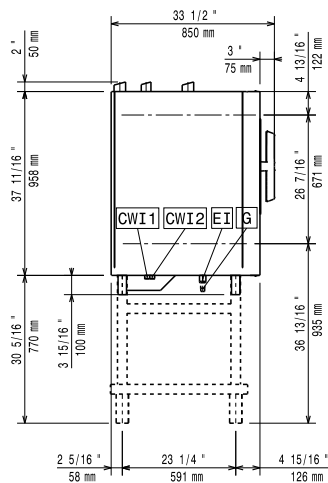

CWI1 = Cold Water inlet      EI = Electrical connection

CWI2 = Cold Water Inlet 2      G = Gas connection

D = Drain

DO = Overflow drain pipe

Top

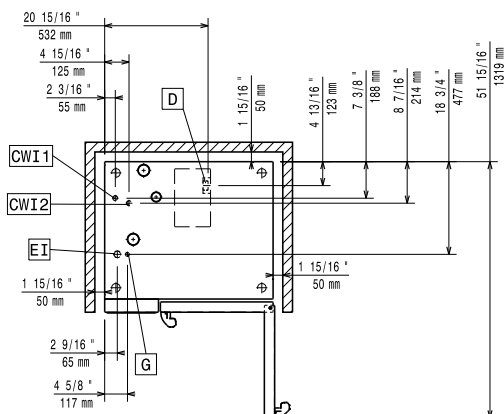

### Electric

<b>Supply voltage:</b>	219962 (ECOG101C200)	120 V/1 ph/60 Hz
<b>Electrical power, default:</b>		1.1 kW
<b>Electrical power, max:</b>		1.1 kW

### Gas

<b>Gas Power:</b>	24.8 kW
<b>Standard gas delivery:</b>	Natural Gas G20
<b>Static Pressure:</b>	< 10" WC
<b>Dynamic Pressure:</b>	7" WC
<b>ISO 7/1 gas connection diameter:</b>	1/2" MNPT

Electrolux Professional does not recommend the use of a GFCI outlet. If a GFCI outlet is required by code, a commercial GFCI with a trip rating of 20 mA must be used.

### Water:

<b>Water Cold Supply Connection:</b>	3/4"
<b>Cold Water Inlet Connection:</b>	3/4" GHT
<b>Pressure:</b>	15-87 psi (1-6 bar)
<b>Drain "D":</b>	2" (50 mm)
<b>Max inlet water supply temperature:</b>	86°F (30°C)
<b>Chlorides:</b>	<10 ppm
<b>Conductivity:</b>	0 µS/cm
<b>Water drain outlet:</b>	1 15/16" (50mm)
<b>Water inlet cold 1:</b>	unfiltered
<b>Water inlet cold 2:</b>	filtered

Electrolux Professional recommends the use of treated water, based on the water specs listed. Refer to manual for details

### Installation:

<b>Clearance:</b>	Clearance: 2 in (5 cm) rear and right hand sides.
<b>Suggested clearance for service access:</b>	20 in (50 cm) left hand side.

### Capacity:

<b>Max load capacity:</b>	110 lbs (50 kg)
<b>Hotel pans:</b>	10 - 12" X 20"
<b>Half-size sheet pans:</b>	10 - 13" X 18"

### Key Information:

<b>Door hinges:</b>	
<b>External dimensions, Width:</b>	34 1/8" (867 mm)
<b>External dimensions, Depth:</b>	30 1/2" (775 mm)
<b>External dimensions, Height:</b>	41 5/8" (1058 mm)
<b>Net weight:</b>	316 lbs (143.5 kg)
<b>Shipping width:</b>	36 5/8" (930 mm)
<b>Shipping depth:</b>	36 5/8" (930 mm)
<b>Shipping height:</b>	50 3/8" (1280 mm)
<b>Shipping weight:</b>	356 lbs (161.5 kg)
<b>Shipping volume:</b>	39.09 ft <sup>3</sup> (1.11 m <sup>3</sup> )

