

SkyLine Pro Natural Gas Boilerless Combi Oven 62 120V

ITEM # _____
 MODEL # _____
 NAME # _____
 SIS # _____
 AIA # _____



219961 (ECOG62C200) SKYLINE Pro DIGITAL
 OVEN 6 FULL SHEET PANS
 (18" X 26") GAS 120V -
 BOILERLESS

Short Form Specification

Item No. _____

Combi oven with high resolution full touch screen interface, multilanguage, IPX5, ETL, EnergyStar, Ergocert

- BOILERLESS
- OptiFlow: air distribution system with 5 fan speed levels
- SkyClean: Automatic and built-in self cleaning system with integrated descale of the steam generator.
- 2 Cooking modes: Programs, Manual
- automatic backup mode to avoid downtime
- USB port to download HACCP data, programs and settings. Connectivity to the cloud ready
- Single sensor core temperature probe
- Double-glass door with double LED lights line
- Retractable hand-shower
- Includes (3) 922076 stainless steel grids

Main Features

- Digital screen: interface with LED backlight buttons with guided selection.
- Instant steam generator: Boilerless steaming function to add and retain moisture for high quality, consistent cooking results. Automatic moistener (11 settings)
- Dry, hot convection cycle (77 °F - 575 °F/25°C - 300 °C): ideal for convection cooking.
- EcoDelta cooking: cooking with food probe maintaining preset temperature difference between the core of the food and the cooking chamber.
- Programs mode: up to 100 recipes can be stored in the oven's memory, to recreate the exact same recipe at any time. 4-step cooking programs also available.
- Reversible Fan: 5 speed fan levels from 300 to 1500 RPM with reverse rotation for optimal evenness. Fan stops in less than 5 seconds when door is opened.
- Single sensor core temperature probe included.
- Automatic cool-down and pre-heat function
- SkyClean: Automatic self cleaning system with integrated descaling of the steam boiler. 5 automatic cycles (soft, medium, strong, extra strong, rinse-only) and green functions to save energy, water, detergent and rinse aid. Also programmable with delayed start.
- Different chemical options available: solid (phosphate-free), liquid (requires optional accessory).
- GreaseOut: predisposed for integrated grease drain and collection for safer operations (dedicated base as optional accessory).
- USB port: to download HACCP data, share cooking programs and configurations. USB port also allows to plug-in sous-vide probe (optional accessory).
- Back-up mode: self-diagnosis is automatically activated if a failure occurs to avoid downtime.
- Capacity: 6 full sheet pans or 12 half sheet/hotel pans.
- OptiFlow air distribution system to achieve maximum performance in chilling/heating evenness and temperature control thanks to a special design of the chamber.

Construction

- Double thermo-glazed door with open frame construction, for cool outside door panel. Swing hinged easy-release inner glass on door for easy cleaning.
- Seamless hygienic internal chamber with all rounded corners for easy cleaning.
- 304 AISI stainless steel construction throughout.
- Front access to control board for easy service.
- IPX 5 spray water protection certification for easy cleaning.
- Supplied with 6 tray rack for full size pans, 2 2/3" pitch.

User Interface & Data Management

- Connectivity: ready for real time access to connected appliances from remote and HACCP monitoring (requires optional accessory).

Sustainability



APPROVAL: _____



- Human centered design: with 4-star certification for ergonomics and usability.
- Door handle: ergonomic wing-shaped design for hands-free door opening with elbow, to allow simple trays management (Registered Design at EPO).

Included Accessories

- 3 of Aisi 304 stainless steel grid (18" x 26") PNC 922076

Optional Accessories

- Caster kit for base for 61, 62, 101 and 102 oven bases only PNC 922003
- Pair of half size oven racks, type 304 stainless steel PNC 922017
- Chicken racks, pair (2) (fits 8 chickens per rack) PNC 922036
- Single 304 stainless steel grid (12" x 20") PNC 922062
- Aisi 304 stainless steel grid (18" x 26") PNC 922076
- External side spray unit PNC 922171
- Pair of 304 stainless steel full-size grids (18" x 26") PNC 922175
- Baguette tray, made of perforated aluminum, silicon coated, 16" x 24" PNC 922189
- Perforated baking tray, made of perforated aluminum, 16" x 24" PNC 922190
- Baking tray, made of aluminum 16" x 24" PNC 922191
- Pair of frying baskets PNC 922239
- Pastry grid 16" x 24" PNC 922264
- Double-click closing catch for oven door PNC 922265
- Grid for whole chicken 1/IGN (8 per grid - 2.6 lbs each) PNC 922266
- Kit universal skewer rack & (6) long skewer ovens (TANDOOR) PNC 922325
- Universal skewer pan for ovens (TANDOOR) PNC 922326
- Skewers for ovens, (6) 14" short (TANDOOR) PNC 922328
- Smoker for ovens PNC 922338
- Multipurpose hook PNC 922348
- 4 FLANGED FEET FOR 61,62,101,102 OVENS - 2" 100-130MM PNC 922351
- Grease collection tray (2 2/5") for 62 and 102 ovens PNC 922357
- Grid for 8 whole ducks (1.8KG, 4LBS) - GN 1/1 PNC 922362
- HOLDER FOR DETERGENT TANK - WALL MOUNTED PNC 922386
- USB SINGLE POINT PROBE PNC 922390
- Slide-in rack with handle for 62, and 102 combi oven PNC 922605
- 5 Tray Rack with wheels, Full Size Sheet Pans, 3" (80mm) pitch for 62 ovens PNC 922611
- Open base with tray support for 62 & 102 combi oven PNC 922613
- Cupboard base with tray support for 62 & 102 combi oven PNC 922616
- External connection kit for detergent and rinse aid PNC 922618

- Stacking kit for gas 62/62 combi ovens PNC 922624
- Stacking kit for gas 62 combi oven placed on 102 gas combi oven PNC 922625
- Trolley for slide-in rack for 62 & 102 ovens and 102 blast chiller. PNC 922627
- Trolley for mobile rack for 2 stacked 62 combi ovens on riser PNC 922629
- Trolley for mobile rack for 62 on 62 or 102 combi ovens PNC 922631
- Riser on feet for 2 stacked 61 combi ovens PNC 922633
- Riser on wheels for 2 stacked 62 combi ovens, height=250mm (9 6/7in) PNC 922634
- Stainless steel drain kit for all oven sizes (61, 62, 101,102, 201,202)-dia=50mm (2") PNC 922636
- Plastic drain kit for all oven sizes (61, 62, 101,102,201, 202), dia=50mm (2") PNC 922637
- Trolley with 2 tanks for grease collection PNC 922638
- Grease collection kit for open base (2 tanks, open/close device and drain) PNC 922639
- Wall support for 62 oven PNC 922644
- Dehydration tray, (12" x 20"), H=2/3" PNC 922651
- Flat dehydration tray, (12" x 20") PNC 922652
- Heat shield for 62 combi oven PNC 922665
- Heat shield for stacked ovens 62 on 62 combi ovens PNC 922666
- Heat shield for stacked ovens 62 on 102 combi ovens PNC 922667
- Kit to convert from natural gas to LPG PNC 922670
- Kit to convert from LPG to natural gas PNC 922671
- Flue condenser for gas oven PNC 922678
- Fixed tray rack, 62 combi oven, h=h=85mm (3 1/3") PNC 922681
- Kit to fix oven to the wall PNC 922687
- Tray support for 62 & 102 oven base PNC 922692
- 4 adjustable feet with black cover for 61,62 & 101,102 combi ovens, 150-200mm (5 9/10in -7 9/1in) PNC 922693
- Detergent tank holder for open base PNC 922699
- 6 Tray Rack with wheels, Full Sheet Pans, 2 1/2" (65mm) pitch for 62 ovens PNC 922700
- Wheels for stacked ovens PNC 922704
- Chimney adaptor PNC 922706
- Mesh grilling grid (12" x 20") PNC 922713
- Probe holder for liquids PNC 922714
- 4 high adjustable feet for 61,62 & 101,102 combi ovens, 230-290mm (9in - 11 2/5in) PNC 922745
- Tray for traditional static cooking, H=100mm (12' x 20") PNC 922746
- Double-face griddle, one side ribbed and one side smooth, 400x600mm PNC 922747
- TROLLEY FOR GREASE COLLECTION KIT PNC 922752
- WATER INLET PRESSURE REDUCER PNC 922773
- Extension for condensation tube, 37cm PNC 922776
- Non-stick universal pan (12" x 20" x 3/4") PNC 925000
- Non-stick universal pan (12" x 20" x 1 1/2") PNC 925001



- Non-stick universal pan (12" x 20" x 2 1/2") PNC 925002
- Frying griddle double sided (ribbed/ smooth) 12" x 20" PNC 925003
- Aluminum combi oven grill (12" x 20") PNC 925004
- Egg fryer for 8 eggs (12" X 20") PNC 925005
- Flat baking tray with 2 edges (12" x 20") PNC 925006
- Potato baker GN 1/1 for 28 potatoes (12"X20") PNC 925008
- Compatibility kit for installation on previous base 62,102 PNC 930218

Front

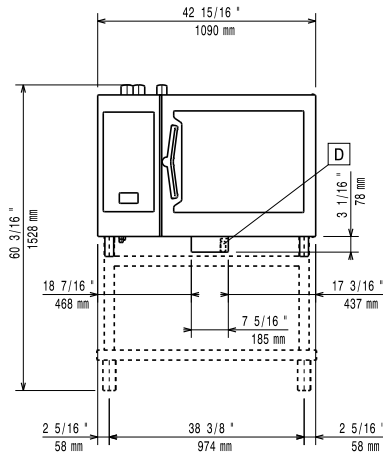

Side

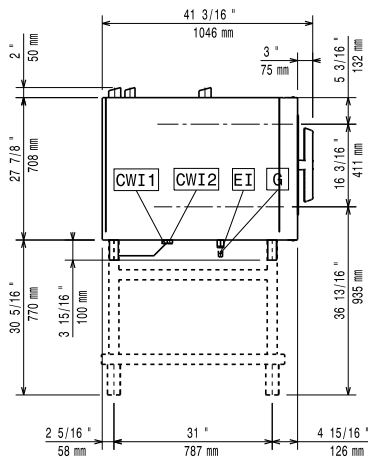

CWI1 = Cold Water inlet EI = Electrical connection

CWI2 = Cold Water Inlet 2 G = Gas connection

D = Drain

DO = Overflow drain pipe

Top

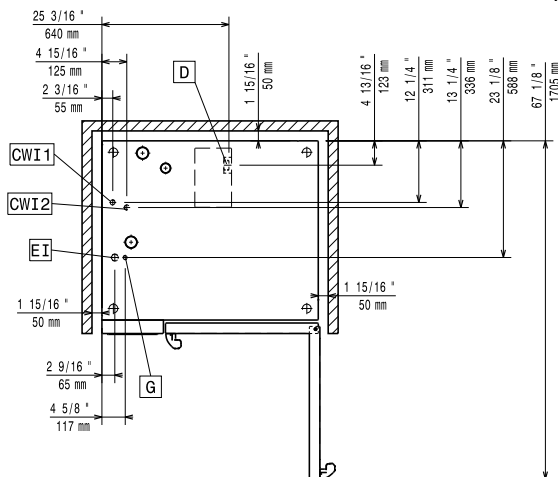

Electric

Supply voltage:
 219961 (ECOG62C200) 120 V/1 ph/60 Hz

Electrical power, default: 1.5 kW

Electrical power, max: 1.5 kW

Gas

Gas Power: 28.3 kW

Standard gas delivery: Natural Gas G20

Static Pressure: < 10" WC

Dynamic Pressure: 7" WC

ISO 7/1 gas connection diameter: 1/2" MNPT

Electrolux Professional does not recommend the use of a GFCI outlet. If a GFCI outlet is required by code, a commercial GFCI with a trip rating of 20 mA must be used.

Water:

Water Cold Supply Connection: 3/4"

Cold Water Inlet Connection: 3/4" GHT

Cold Water Inlet Connection: 3/4" GHT

Pressure: 15-87 psi (1-6 bar)

Drain "D": 2" (50 mm)

Max inlet water supply temperature: 86°F (30°C)

Chlorides: <10 ppm

Conductivity: 0 µS/cm

Water inlet cold 1: unfiltered

Water inlet cold 2 filtered

Electrolux Professional recommends the use of treated water, based on the water specs listed. Refer to manual for details

Installation:

Clearance: Clearance: 2 in (5 cm) rear and right hand sides.

Suggested clearance for service access: 20 in (50 cm) left hand side.

Capacity:

Max load capacity: 132 lbs (60 kg)

Full-size sheet pans: 6 - 18" X 26"

Key Information:

Door hinges:

External dimensions, Width: 42 15/16" (1090 mm)

External dimensions, Depth: 38 1/4" (971 mm)

External dimensions, Height: 31 13/16" (808 mm)

Net weight: 354 lbs (160.5 kg)

Shipping width: 44 1/2" (1130 mm)

Shipping depth: 43 5/16" (1100 mm)

Shipping height: 40 9/16" (1030 mm)

Shipping weight: 405 lbs (183.5 kg)

Shipping volume: 45.21 ft³ (1.28 m³)

