

## SkyLine Pro

### Electric Boilerless Combi Oven 102 208V

ITEM # \_\_\_\_\_

MODEL # \_\_\_\_\_

NAME # \_\_\_\_\_

SIS # \_\_\_\_\_

AIA # \_\_\_\_\_



219933 (ECO102C2L0)

SKYLINE Pro DIGITAL  
 OVEN 10 FULL SHEET PANS  
 (18" X 26")ELECTRIC 208V -  
 BOILERLESS

### Short Form Specification

**Item No.** \_\_\_\_\_

- Combi oven with high resolution full touch screen interface, multilanguage, IPX5, ETL, EnergyStar, Ergocert
- BOILERLESS
  - OptiFlow: air distribution system with 5 fan speed levels
  - SkyClean: Automatic and built-in self cleaning system with integrated descale of the steam generator.
  - 2 Cooking modes: Programs, Manual
  - automatic backup mode to avoid downtime
  - USB port to download HACCP data, programs and settings. Connectivity to the cloud ready
  - Single sensor core temperature probe
  - Double-glass door with double LED lights line
  - Retractable hand-shower
  - Includes (5) 922076 stainless steel grids

### Main Features

- Digital screen: interface with LED backlight buttons with guided selection.
- Instant steam generator: Boilerless steaming function to add and retain moisture for high quality, consistent cooking results. Automatic moistener (11 settings)
- Dry, hot convection cycle (77 °F - 575 °F/25°C - 300 °C): ideal for convection cooking.
- EcoDelta cooking: cooking with food probe maintaining preset temperature difference between the core of the food and the cooking chamber.
- Programs mode: up to 100 recipes can be stored in the oven's memory, to recreate the exact same recipe at any time. 4-step cooking programs also available.
- Reversible Fan: 5 speed fan levels from 300 to 1500 RPM with reverse rotation for optimal evenness. Fan stops in less than 5 seconds when door is opened.
- Single sensor core temperature probe included.
- Automatic cool-down and pre-heat function
- SkyClean: Automatic self cleaning system with integrated descaling of the steam boiler. 5 automatic cycles (soft, medium, strong, extra strong, rinse-only) and green functions to save energy, water, detergent and rinse aid. Also programmable with delayed start.
- Different chemical options available: solid (phosphate-free), liquid (requires optional accessory).
- GreaseOut: predisposed for integrated grease drain and collection for safer operations (dedicated base as optional accessory).
- USB port: to download HACCP data, share cooking programs and configurations. USB port also allows to plug-in sous-vide probe (optional accessory).
- Back-up mode: self-diagnosis is automatically activated if a failure occurs to avoid downtime.
- Capacity: 10 full sheet pans or 20 half sheet/hotel pans.
- OptiFlow air distribution system to achieve maximum performance in chilling/heating evenness and temperature control thanks to a special design of the chamber.

### Construction

- Double thermo-glazed door with open frame construction, for cool outside door panel. Swing hinged easy-release inner glass on door for easy cleaning.
- Seamless hygienic internal chamber with all rounded corners for easy cleaning.
- 304 AISI stainless steel construction throughout.
- Front access to control board for easy service.
- IPX 5 spray water protection certification for easy cleaning.
- Supplied with 6 tray rack for full size pans, 2 2/3" pitch.

### User Interface & Data Management

- Connectivity: ready for real time access to connected appliances from remote and HACCP monitoring (requires optional accessory).

### Sustainability



APPROVAL: \_\_\_\_\_



- Human centered design: with 4-star certification for ergonomics and usability.
- Door handle: ergonomic wing-shaped design for hands-free door opening with elbow, to allow simple trays management (Registered Design at EPO).

**Included Accessories**

- 5 of Aisi 304 stainless steel grid (18" x 26") PNC 922076

**Optional Accessories**

- Caster kit for base for 61, 62, 101 and 102 oven bases only PNC 922003
- Pair of half size oven racks, type 304 stainless steel PNC 922017
- Chicken racks, pair (2) (fits 8 chickens per rack) PNC 922036
- Single 304 stainless steel grid (12" x 20") PNC 922062
- Aisi 304 stainless steel grid (18" x 26") PNC 922076
- External side spray unit PNC 922171
- Pair of 304 stainless steel full-size grids (18" x 26") PNC 922175
- Baguette tray, made of perforated aluminum, silicon coated, 16" x 24" PNC 922189
- Perforated baking tray, made of perforated aluminum, 16" x 24" PNC 922190
- Baking tray, made of aluminum 16" x 24" PNC 922191
- Pair of frying baskets PNC 922239
- Pastry grid 16" x 24" PNC 922264
- Double-click closing catch for oven door PNC 922265
- Grid for whole chicken 1/IGN (8 per grid - 2.6 lbs each) PNC 922266
- Kit universal skewer rack & (6) long skewer ovens (TANDOOR) PNC 922325
- Universal skewer pan for ovens (TANDOOR) PNC 922326
- Skewers for ovens, (6) 14" short (TANDOOR) PNC 922328
- Multipurpose hook PNC 922348
- 4 FLANGED FEET FOR 61,62,101,102 OVENS - 2" 100-130MM PNC 922351
- Grease collection tray (2 2/5") for 62 and 102 ovens PNC 922357
- Grid for 8 whole ducks (1.8KG, 4LBS) - GN 1/1 PNC 922362
- Thermal blanket for 102 oven (trolley not included) PNC 922366
- HOLDER FOR DETERGENT TANK - WALL MOUNTED PNC 922386
- USB SINGLE POINT PROBE PNC 922390
- 10 Tray Rack with wheels, Full Sheet Pans, 2 1/2" (65mm) pitch for 102 ovens and blast chillers PNC 922603
- 8 Tray Rack with wheels, Full Size Sheet Pans, 3" (80mm) pitch for 102 ovens and blast chillers PNC 922604
- Slide-in rack with handle for 62, and 102 combi oven PNC 922605

- Bakery/pastry tray rack with wheels 400x600mm for 10 GN 2/1 oven and blast chiller freezer, 80mm pitch (8 runners) PNC 922609
- Open base with tray support for 62 & 102 combi oven PNC 922613
- External connection kit for detergent and rinse aid PNC 922618
- Stacking kit for electric 62 combi oven placed on 62 electric combi oven or 102 combi oven PNC 922621
- Trolley for slide-in rack for 62 & 102 ovens and 102 blast chiller. PNC 922627
- Trolley for mobile rack for 62 on 62 or 102 combi ovens PNC 922631
- Stainless steel drain kit for all oven sizes (61, 62, 101,102, 201,202)-dia=50mm (2") PNC 922636
- Plastic drain kit for all oven sizes (61, 62, 101,102,201, 202), dia=50mm (2") PNC 922637
- Trolley with 2 tanks for grease collection PNC 922638
- Grease collection kit for open base (2 tanks, open/close device and drain) PNC 922639
- Banquet rack with wheels holding 51 plates for 102 oven and blast chiller freezer, 75mm pitch ( 3" 1/3") PNC 922650
- Dehydration tray, (12" x 20"), H=2/3" PNC 922651
- Flat dehydration tray, (12" x 20") PNC 922652
- Heat shield for 102 combi oven PNC 922664
- Heat shield for stacked ovens 62 on 102 combi ovens PNC 922667
- Kit to fix oven to the wall PNC 922687
- Tray support for 62 & 102 oven base PNC 922692
- 4 adjustable feet with black cover for 61,62 & 101,102 combi ovens, 150-200mm (5 9/10in -7 9/1in) PNC 922693
- Detergent tank holder for open base PNC 922699
- Wheels for stacked ovens PNC 922704
- Mesh grilling grid (12" x 20") PNC 922713
- Probe holder for liquids PNC 922714
- 4 high adjustable feet for 61,62 & 101,102 combi ovens, 230-290mm (9in - 11 2/5in) PNC 922745
- Tray for traditional static cooking, H=100mm (12' x 20") PNC 922746
- Double-face griddle, one side ribbed and one side smooth, 400x600mm PNC 922747
- TROLLEY FOR GREASE COLLECTION KIT PNC 922752
- WATER INLET PRESSURE REDUCER PNC 922773
- KIT FOR INSTALLATION OF ELECTRIC POWER PEAK MANAGEMENT SYSTEM-6-10 GN OVENS PNC 922774
- Extension for condensation tube, 37cm PNC 922776
- Non-stick universal pan (12" x 20" x 3/4") PNC 925000
- Non-stick universal pan (12" x 20" x 1 1/2") PNC 925001
- Non-stick universal pan (12" x 20" x 2 1/2") PNC 925002
- Frying griddle double sided (ribbed/smooth) 12" x 20" PNC 925003
- Aluminum combi oven grill (12" x 20") PNC 925004



**Electrolux**  
PROFESSIONAL

**SkyLine Pro**  
**Electric Boilerless Combi Oven 102**  
**208V**

- Egg fryer for 8 eggs (12" X 20") PNC 925005
- Flat baking tray with 2 edges (12" x 20") PNC 925006
- Potato baker GN 1/1 for 28 potatoes (12"X20") PNC 925008
- Compatibility kit for installation on previous base 62,102 PNC 930218

Front

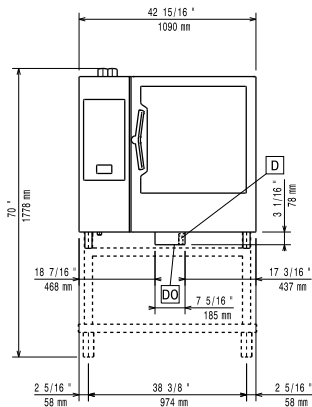

Side

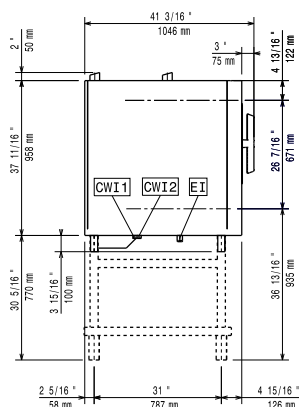

CWI1 = Cold Water inlet      EI = Electrical connection

CWI2 = Cold Water Inlet 2

D = Drain

DO = Overflow drain pipe

Top

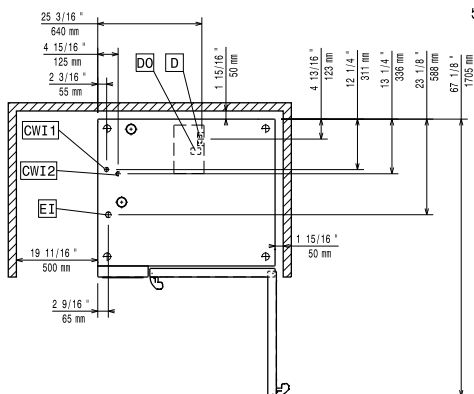

### Electric

#### Supply voltage:

219933 (ECO E102C2L0)      208 V/3 ph/60 Hz

#### Electrical power, default:

35.4 kW

#### Electrical power, max:

35.4 kW

### Water:

#### Water Cold Supply

Connection:      3/4"

Cold Water Inlet Connection:      3/4" GHT

Pressure:      15-87 psi (1-6 bar)

Drain "D":      2" (50 mm)

#### Max inlet water supply

temperature:      86°F (30°C)

Chlorides:      <10 ppm

Conductivity:      >50 µS/cm

Water inlet cold 1:      unfiltered

Water inlet cold 2:      filtered

**Electrolux Professional** recommends the use of treated water, based on testing of specific water conditions. Refer to manual for details

### Installation:

#### Clearance:

Clearance: 2 in (5 cm) rear and right hand sides.

#### Suggested clearance for service access:

20 in (50 cm) left hand side.

### Capacity:

Max load capacity:      220 lbs (100 kg)

Full-size sheet pans:      10 - 18" X 26"

### Key Information:

#### Door hinges:

External dimensions, Width:      42 15/16" (1090 mm)

External dimensions, Depth:      38 1/4" (971 mm)

External dimensions, Height:      41 5/8" (1058 mm)

Net weight:      376 lbs (170.5 kg)

Shipping width:      44 1/2" (1130 mm)

Shipping depth:      43 5/16" (1100 mm)

Shipping height:      50 3/8" (1280 mm)

Shipping weight:      431 lbs (195.5 kg)

Shipping volume:      56.18 ft<sup>3</sup> (1.59 m<sup>3</sup>)

### ISO Certificates

#### ISO Standards:

ISO 9001; ISO 14001; ISO 45001; ISO 50001

### Sustainability

#### Current consumption:

97.6 Amps