

SkyLine Pro

Electric Boilerless Combi Oven 61 208V

ITEM # _____

MODEL # _____

NAME # _____

SIS # _____

AIA # _____



219930 (ECO61C2L0)

SKYLINE Pro DIGITAL
 OVEN 6 HALF SHEET PANS
 (13" X 18") OR 6 HOTEL
 PANS (12" X 20") ELECTRIC
 208V -BOILERLESS

Short Form Specification

Item No. _____

- Combi oven with high resolution full touch screen interface, multilanguage, IPX5, ETL, EnergyStar, Ergocert
- BOILERLESS
 - OptiFlow: air distribution system with 5 fan speed levels
 - SkyClean: Automatic and built-in self cleaning system with integrated descale of the steam generator.
 - 2 Cooking modes: Programs, Manual
 - automatic backup mode to avoid downtime
 - USB port to download HACCP data, programs and settings. Connectivity to the cloud ready
 - Single sensor core temperature probe
 - Double-glass door with double LED lights line
 - Retractable hand-shower
 - Includes (3) 922062 stainless steel grids

Main Features

- Digital screen: interface with LED backlight buttons with guided selection.
- Instant steam generator: Boilerless steaming function to add and retain moisture for high quality, consistent cooking results. Automatic moistener (11 settings)
- Dry, hot convection cycle (77 °F - 575 °F/25°C - 300 °C): ideal for convection cooking.
- EcoDelta cooking: cooking with food probe maintaining preset temperature difference between the core of the food and the cooking chamber.
- Programs mode: up to 100 recipes can be stored in the oven's memory, to recreate the exact same recipe at any time. 4-step cooking programs also available.
- Reversible Fan: 5 speed fan levels from 300 to 1500 RPM with reverse rotation for optimal evenness. Fan stops in less than 5 seconds when door is opened.
- Single sensor core temperature probe included.
- Automatic cool-down and pre-heat function
- SkyClean: Automatic self cleaning system with integrated descaling of the steam boiler. 5 automatic cycles (soft, medium, strong, extra strong, rinse-only) and green functions to save energy, water, detergent and rinse aid. Also programmable with delayed start.
- Different chemical options available: solid (phosphate-free), liquid (requires optional accessory).
- GreaseOut: predisposed for integrated grease drain and collection for safer operations (dedicated base as optional accessory).
- USB port: to download HACCP data, share cooking programs and configurations. USB port also allows to plug-in sous-vide probe (optional accessory).
- Back-up mode: self-diagnosis is automatically activated if a failure occurs to avoid downtime.
- Capacity: 6 half sheet/hotel pans.
- OptiFlow air distribution system to achieve maximum performance in chilling/heating evenness and temperature control thanks to a special design of the chamber.

Construction

- Double thermo-glazed door with open frame construction, for cool outside door panel. Swing hinged easy-release inner glass on door for easy cleaning.
- Seamless hygienic internal chamber with all rounded corners for easy cleaning.
- 304 AISI stainless steel construction throughout.
- Front access to control board for easy service.
- IPX 5 spray water protection certification for easy cleaning.
- Supplied with 6 tray rack for hotel pans, 2 2/3" pitch (67 mm).

User Interface & Data Management

- Connectivity: ready for real time access to connected appliances from remote and HACCP monitoring (requires optional accessory).

APPROVAL: _____



Sustainability

- Human centered design: with 4-star certification for ergonomics and usability.
- Door handle: ergonomic wing-shaped design for hands-free door opening with elbow, to allow simple trays management (Registered Design at EPO).

Included Accessories

- 3 of Single 304 stainless steel grid (12" x 20") PNC 922062

Optional Accessories

- Caster kit for base for 61, 62, 101 and 102 oven bases only PNC 922003
- Pair of half size oven racks, type 304 stainless steel PNC 922017
- Chicken racks, pair (2) (fits 8 chickens per rack) PNC 922036
- Single 304 stainless steel grid (12" x 20") PNC 922062
- Stainless steel 304 grids (GN ½) with spikes, fits 4 chickens PNC 922086
- External side spray unit PNC 922171
- Baguette tray, made of perforated aluminum, silicon coated, 16" x 24" PNC 922189
- Perforated baking tray, made of perforated aluminum, 16" x 24" PNC 922190
- Baking tray, made of aluminum 16" x 24" PNC 922191
- Pair of frying baskets PNC 922239
- Pastry grid 16" x 24" PNC 922264
- Double-click closing catch for oven door PNC 922265
- Grid for whole chicken 1/1GN (8 per grid - 2.6 lbs each) PNC 922266
- Grease collection tray (4") for 61 and 101 ovens PNC 922321
- Kit universal skewer rack & (4) long skewer ovens (TANDOOR) PNC 922324
- Universal skewer pan for ovens (TANDOOR) PNC 922326
- Skewers for ovens, (4) 24" long (TANDOOR) PNC 922327
- Smoker for ovens PNC 922338
- Multipurpose hook PNC 922348
- 4 FLANGED FEET FOR 61,62,101,102 OVENS - 2" 100-130MM PNC 922351
- Grid for 8 whole ducks (1.8KG, 4LBS) - GN 1/1 PNC 922362
- HOLDER FOR DETERGENT TANK - WALL MOUNTED PNC 922386
- USB SINGLE POINT PROBE PNC 922390
- 6 Tray Rack with wheels, Half Sheet Pans, 2 ½" (65mm) pitch for 61 ovens and blast chillers PNC 922600
- 5 Tray Rack with wheels, Half Sheet Pans, 3" (80mm) pitch, for 61 ovens and blast chillers PNC 922606
- Bakery/pastry tray rack with wheels 400x600mm for 6 GN 1/1 oven and blast chiller freezer, 80mm pitch (5 runners) PNC 922607
- Slide-in rack with handle for 61 and 101 combi oven PNC 922610

- Open base with tray support for 61 & 101 combi oven PNC 922612
- Cupboard base with tray support for 61 & 101 combi oven PNC 922614
- HOT CUPBOARD BASE WITH TRAY SUPPORT FOR 61 AND 101 OVEN HALF SHEET PANS (12" X 20") PNC 922615
- External connection kit for detergent and rinse aid PNC 922618
- Grease collection kit for 61,62,101,102 cupboard base (trolley with 2 tanks, open/close device and drain) PNC 922619
- Stacking kit for electric 61/61 combi ovens or electric 61/101 combi ovens PNC 922620
- Trolley for slide-in rack for 61 and 101 combi oven and blast chiller freezer PNC 922626
- Trolley for mobile rack for 2 stacked 61 combi ovens on riser PNC 922628
- Trolley for mobile rack for 61 on 61 or 101 combi ovens PNC 922630
- RISER ON FEET FOR STACKED 2X6 GN 1/1 OVENS OR 6 GN 1/1 OVEN ON BASE PNC 922632
- Riser on wheels for 2 stacked 61 combi ovens, height=250mm (9 6/7in) PNC 922635
- Stainless steel drain kit for all oven sizes (61, 62, 101,102, 201,202)-dia=50mm (2") PNC 922636
- Plastic drain kit for all oven sizes (61, 62, 101,102,201, 202), dia=50mm (2") PNC 922637
- Trolley with 2 tanks for grease collection PNC 922638
- Grease collection kit for open base (2 tanks, open/close device and drain) PNC 922639
- Wall support for 61 oven PNC 922643
- Dehydration tray, (12" x 20"), H=2/3" PNC 922651
- Flat dehydration tray, (12" x 20") PNC 922652
- Bakery/pastry rack kit for 6 GN 1/1 oven with 5 racks 400x600mm and 80mm pitch PNC 922655
- Stacking kit for gas 6 GN 1/1 oven placed on 7kg and 15kg crosswise blast chiller freezer PNC 922657
- Heat shield for stacked ovens 61 on 61 combi ovens PNC 922660
- Heat shield for stacked ovens 61 on 101 combi ovens PNC 922661
- Heat shield for 61 combi oven PNC 922662
- Compatibility kit for installation of 61 Skyline electric combi oven on previous generation 61 electric combi oven PNC 922679
- Fixed tray rack for 6 GN 1/1 and 400x600mm grids PNC 922684
- Kit to fix oven to the wall PNC 922687
- Tray support for 61 & 101 oven base PNC 922690
- 4 adjustable feet with black cover for 61,62 & 101,102 combi ovens, 150-200mm (5 9/10in -7 9/11in) PNC 922693
- Detergent tank holder for open base PNC 922699
- Bakery/pastry runners 400x600mm for 6 & 10 GN 1/1 oven base PNC 922702
- Wheels for stacked ovens PNC 922704
- Mesh grilling grid (12" x 20") PNC 922713



- Probe holder for liquids PNC 922714
- Fixed tray rack, 61 combi oven, h=85mm (3 1/3") PNC 922740
- 4 high adjustable feet for 61,62 & 101,102 combi ovens, 230-290mm (9in - 11 2/5in) PNC 922745
- Tray for traditional static cooking, H=100mm (12" x 20") PNC 922746
- Double-face griddle, one side ribbed and one side smooth, 400x600mm PNC 922747
- TROLLEY FOR GREASE COLLECTION KIT PNC 922752
- WATER INLET PRESSURE REDUCER PNC 922773
- KIT FOR INSTALLATION OF ELECTRIC POWER PEAK MANAGEMENT SYSTEM-6-10 GN OVENS PNC 922774
- Extension for condensation tube, 37cm PNC 922776
- Non-stick universal pan (12" x 20" x 3/4") PNC 925000
- Non-stick universal pan (12" x 20" x 1 1/2") PNC 925001
- Non-stick universal pan (12" x 20" x 2 1/2") PNC 925002
- Frying griddle double sided (ribbed/smooth) 12" x 20" PNC 925003
- Aluminum combi oven grill (12" x 20") PNC 925004
- Egg fryer for 8 eggs (12" X 20") PNC 925005
- Flat baking tray with 2 edges (12" x 20") PNC 925006
- Baking tray for (4) baguettes (12" x 20") PNC 925007
- Potato baker GN 1/1 for 28 potatoes (12"X20") PNC 925008
- Non-stick U-pan (12" x 10" x 3/4") PNC 925009
- Non-stick U-pan (12" x 10" x 1 1/2") PNC 925010
- Non-stick U-pan (12" x 10" x 2 1/2") PNC 925011
- Compatibility kit for installation on previous base 61,101 PNC 930217

Front

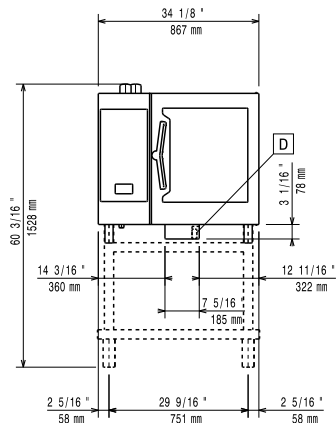

Side

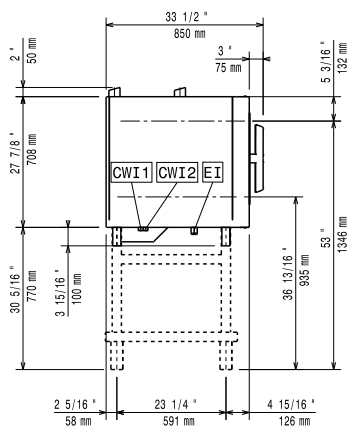

CWI1 = Cold Water inlet EI = Electrical connection

CWI2 = Cold Water Inlet 2

D = Drain

DO = Overflow drain pipe

Top

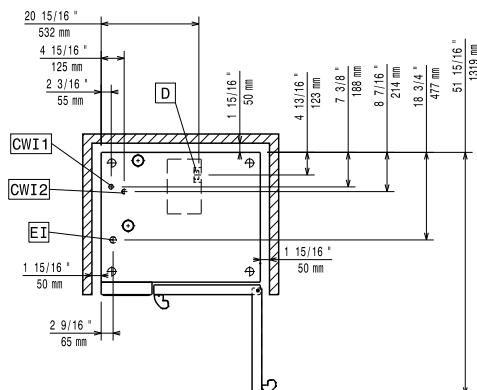

Electric

Supply voltage:

219930 (ECOE61C2L0) 208 V/3 ph/60 Hz

Electrical power, default:

11.1 kW

Electrical power, max:

11.1 kW

Water:

Water Cold Supply

Connection: 3/4"

Cold Water Inlet Connection: 3/4" GHT

Pressure: 15-87 psi (1-6 bar)

Drain "D": 2" (50 mm)

Max inlet water supply

temperature: 86°F (30°C)

Chlorides: <10 ppm

Conductivity: >50 µS/cm

Water inlet cold 1: unfiltered

Water inlet cold 2: filtered

Electrolux Professional recommends the use of treated water, based on testing of specific water conditions. Refer to manual for details

Installation:

Clearance:

Clearance: 2 in (5 cm) rear and right hand sides.

Suggested clearance for service access:

20 in (50 cm) left hand side.

Capacity:

Max load capacity: 66 lbs (30 kg)

Hotel pans: 6 - 12" X 20"

Half-size sheet pans: 6 - 13" X 18"

Key Information:

Door hinges:

External dimensions, Width: 34 1/8" (867 mm)

External dimensions, Depth: 30 1/2" (775 mm)

External dimensions, Height: 31 13/16" (808 mm)

Net weight: 246 lbs (111.5 kg)

Shipping width: 36 5/8" (930 mm)

Shipping depth: 36 5/8" (930 mm)

Shipping height: 40 9/16" (1030 mm)

Shipping weight: 283 lbs (128.5 kg)

Shipping volume: 31.46 ft³ (0.89 m³)

ISO Certificates

ISO Standards:

ISO 9001; ISO 14001; ISO 45001; ISO 50001

Sustainability

Current consumption:

31.9 Amps