

SkyLine PremiumS Natural Gas Boiler Combi Oven 202 120V

ITEM # _____

MODEL # _____

NAME # _____

SIS # _____

AIA # _____



219785 (ECOG202T300)

SKYLINE PremiumS 20
FULL SHEET PANS (18" X
26") TOUCH-GAS 120V-
BOILER

Short Form Specification

Item No. _____

Combi oven with high resolution full touch screen interface, multilanguage, IPX5, ETL, EnergyStar, Ergocert

- Built-in BOILER (in s/s 316L) with Lambda Sensor
- OptiFlow: air distribution system with 7 fan speed levels
- SkyClean: Automatic and built-in self cleaning system with integrated descale of the steam generator.
- 3 Cooking modes: Automatic, Programs, Manual
- Special functions: MultiTimer cooking, Plan-n-Save, SkyHub homepage, agenda MyPlanner, SkyDuo connection to SkyLine ChillerS, automatic backup mode to avoid downtime
- USB port to download HACCP data, programs and settings. Connectivity to the cloud ready
- 6-point multi sensor core temperature probe
- Triple-glass door with double LED lights line
- Includes (10) 922076 stainless steel grids
- Includes (1) 922757 trolley

Main Features

- Built-in steam generator: Boiler in AISI 316 steel for highly precise humidity and temperature control according to the chosen settings.
- Lambda Sensor: Real humidity control of +-1% for automatic quantity and size of food recognition to guarantee consistent cooking results
- Dry, hot convection cycle (77 °F - 575 °F/25 °C - 300 °C): ideal for convection cooking.
- Combi cycle (77 °F - 575 °F/25 °C - 300 °C): The combination of hot air and steam creating a humidity controlled cooking environment, to reduce the cooking process times and food weight loss.
- Steam cycle (77 °F - 266°F/25 °C - 130°C): Ideal for sous vide, re-thermalization, and Low Steaming of food and vegetables
- Automatic Cooking Mode: includes 9 food families (meat, poultry, fish, vegetables, pasta/rice, eggs, pastries and sweet bakery, bread, dessert) with 100+ different pre-installed variations. The Automatic Sensory Phase of the oven optimizes the cooking process according to the size, quantity and type of food loaded in the oven. Real-time monitoring of cooking parameters. Personalize and save up to 70 variations per food family.
- Cycles+: Regeneration (ideal for banqueting on plate or rethermalizing on tray)
 - Low Temperature Cooking (to minimize weight loss and maximize food quality) Patented US7750272B2 and related family
 - Proving cycle
 - EcoDelta cooking, cooking with the difference between the food probe core temperature of the food and the cooking cavity
 - Sous-vide cooking
 - Static Combi (to reproduce traditional cooking from static oven)
 - Pasteurization of pasta
 - Dehydration cycles (ideal for drying fruits, vegetables, meats, seafood)
 - Food safe Control and Advanced Food Safe Control: to automatically monitor safely the cooking process in compliance with HACCP hygienic standards or drive cooking with pasteurization factor Patented US6818865B2 and related family
- Programs mode: a maximum of 1000 recipes can be stored in the oven's memory, to recreate the exact same recipe at any time. The recipes can be group in 16 different categories to better organize the menu. 16-step cooking programs also available.
- MultiTimer: Special feature to manage up to 20 different cooking cycles at the same time in the same cavity guaranteeing even cooking results. Up to 200 MultiTimer available programs
- Reversible Fan: 7 speed fan levels from 300 to 1500 RPM with reverse rotation for optimal evenness. Fan stops in less than 5 seconds when door is opened.
- 6-point multi sensor core temperature probe for maximum precision and food safety.
- Picture Management: upload full customized images of cooking cycles or food items

APPROVAL: _____

- Automatic cool-down and pre-heat function
- Different chemical options available: solid (phosphate-free), liquid (requires optional accessory).
- GreaseOut: predisposed for integrated grease drain and collection for safer operations (dedicated base as optional accessory).
- USB port: to download HACCP data, share cooking programs and configurations. USB port also allows to plug-in sous-vide probe (optional accessory).
- Back-up mode: self-diagnosis is automatically activated if a failure occurs to avoid downtime.
- Capacity: 20 full sheet pans or 40 half sheet/hotel pans.
- OptiFlow air distribution system to achieve maximum performance in chilling/heating evenness and temperature control thanks to a special design of the chamber.

Construction

- Seamless hygienic internal chamber with all rounded corners for easy cleaning.
- 304 AISI stainless steel construction throughout.
- Front access to control board for easy service.
- Integrated spray gun with automatic retracting system for fast rinsing.
- IPX 5 spray water protection certification for easy cleaning.
- Integrated door shield to avoid steam and heat dispersion from the door, when the roll-in rack is not used.
- Supplied with one full-size sheet trolley, 2 1/2" pitch.

User Interface & Data Management

- Touchscreen: High resolution interface (translated into more than 30 languages including Spanish and French) - color-blind friendly panel.
- Make-it-mine: feature to allow full personalization or locking of the user interface by selecting what is visible on screen
- SkyHub: customizable homepage to allow the user to group their favorite functions for immediate access when operating.
- MyPlanner: on-screen agenda where the user can plan their daily work, set reminders for several users and receive personalized alerts for each activity
- SkyDuo: Oven and Blast Chiller automatic communication to guide the user through the cook&chill process by creating a safe controlled environment to optimize time and efficiency (requires optional accessory).
- Connectivity: ready for real time access to connected appliances from remote and HACCP monitoring (requires optional accessory).
- e-learning: equipment trainings, how-to guides, and technical documentation easily accessible by scanning QR-Code with any mobile device.
- Data Analytics: automatic consumption visualization at the end of the cycle.

Sustainability



- Human centered design: with 4-star certification for ergonomics and usability.
- Door handle: ergonomic wing-shaped design for hands-free door opening with elbow, to allow simple trays management (Registered Design at EPO).
- Reduced-Power Feature: To consume less energy during customized slow cooking cycles.
- SkyClean: Automatic self cleaning system with integrated descaling of the steam boiler. 5 automatic cycles (soft, medium, strong, extra strong, rinse-only) and green

functions to save energy, water, detergent and rinse aid. Also programmable with delayed start.

- Plan-n-Save: the oven organizes the sequence of the chosen cooking cycles to optimize the processes in the kitchen reducing time and energy consumption.

Included Accessories

- 10 of Aisi 304 stainless steel grid (18" x 26") PNC 922076
- 1 of 20 Tray Rack Trolley, Full Sheet Pans, 2 1/2" (63mm) pitch for 202 ovens and blast chillers PNC 922757

Optional Accessories

- | | | |
|---|------------|--------------------------|
| • Water softener with cartridge STEAM 1200 | PNC 920003 | <input type="checkbox"/> |
| • Automatic water softener for ovens | PNC 921305 | <input type="checkbox"/> |
| • Pair of half size oven racks, type 304 stainless steel | PNC 922017 | <input type="checkbox"/> |
| • Chicken racks, pair (2) (fits 8 chickens per rack) | PNC 922036 | <input type="checkbox"/> |
| • Single 304 stainless steel grid (12" x 20") | PNC 922062 | <input type="checkbox"/> |
| • External side spray unit | PNC 922171 | <input type="checkbox"/> |
| • Baguette tray, made of perforated aluminum, silicon coated, 16" x 24" | PNC 922189 | <input type="checkbox"/> |
| • Perforated baking tray, made of perforated aluminum, 16" x 24" | PNC 922190 | <input type="checkbox"/> |
| • Baking tray, made of aluminum 16" x 24" | PNC 922191 | <input type="checkbox"/> |
| • Pair of frying baskets | PNC 922239 | <input type="checkbox"/> |
| • Pastry grid 16" x 24" | PNC 922264 | <input type="checkbox"/> |
| • Grid for whole chicken 1/1GN (8 per grid - 2.6 lbs each) | PNC 922266 | <input type="checkbox"/> |
| • USB Probe for sous-vide cooking (only for Touchline ovens) | PNC 922281 | <input type="checkbox"/> |
| • Universal skewer pan for ovens (TANDOOR) | PNC 922326 | <input type="checkbox"/> |
| • Skewers for ovens, (6) 14" short (TANDOOR) | PNC 922328 | <input type="checkbox"/> |
| • Smoker for ovens | PNC 922338 | <input type="checkbox"/> |
| • Multipurpose hook | PNC 922348 | <input type="checkbox"/> |
| • Grease collection tray (2 2/5") for 62 and 102 ovens | PNC 922357 | <input type="checkbox"/> |
| • Grid for 8 whole ducks (1.8KG, 4LBS) - GN 1/1 | PNC 922362 | <input type="checkbox"/> |
| • Thermal blanket for 202 oven (trolley not included) | PNC 922367 | <input type="checkbox"/> |
| • HOLDER FOR DETERGENT TANK - WALL MOUNTED | PNC 922386 | <input type="checkbox"/> |
| • USB SINGLE POINT PROBE | PNC 922390 | <input type="checkbox"/> |
| • External connection kit for detergent and rinse aid | PNC 922618 | <input type="checkbox"/> |
| • Dehydration tray, (12" x 20"), H=2/3" | PNC 922651 | <input type="checkbox"/> |
| • Flat dehydration tray, (12" x 20") | PNC 922652 | <input type="checkbox"/> |
| • Heat shield for 202 combi oven | PNC 922658 | <input type="checkbox"/> |
| • Kit to convert from natural gas to LPG | PNC 922670 | <input type="checkbox"/> |
| • Kit to convert from LPG to natural gas | PNC 922671 | <input type="checkbox"/> |
| • Flue condenser for gas oven | PNC 922678 | <input type="checkbox"/> |
| • Trolley with tray rack, 202 combi oven, h=85mm (3 1/3") | PNC 922686 | <input type="checkbox"/> |
| • Kit to fix oven to the wall | PNC 922687 | <input type="checkbox"/> |



- 4 flanged feet for 201 and 202 combi ovens , 2", 100-130mm (4"-5") PNC 922707
- Mesh grilling grid (12" x 20") PNC 922713
- Probe holder for liquids PNC 922714
- Holder for trolley handle (when trolley is in the oven) for 201 and 202 combi ovens PNC 922743
- Tray for traditional static cooking, H=100mm (12' x 20") PNC 922746
- Double-face griddle, one side ribbed and one side smooth, 400x600mm PNC 922747
- 20 Tray Rack Trolley, Full Sheet Pans, 2 ½" (63mm) pitch for 202 ovens and blast chillers PNC 922757
- 16 Tray Rack Trolley, Full Sheet Pans, 3" (80mm) pitch for 202 ovens and blast chillers PNC 922758
- 202 Banquet trolley for oven and blast chiller for 92 plates holding , 3.3 " (85mm) pitch PNC 922760
- BAKERY/PASTRY TROLLEY FOR 20 GN 2/1 OVEN - 16 RACKS 400X600MM - 80MM PITCH PNC 922762
- 201 Banquet trolley for combi and blast chiller for 116 plates holding, 2.5" 66mm pitch PNC 922764
- KIT COMPATIBILITY FOR AOS/EASYLINE TROLLEYS (PRODUCED TILL 2019) WITH SKYLINE/MAGISTAR COMBI OVENS 20GN2/1 PNC 922770
- KIT COMPATIBILITY FOR AOS/EASYLINE OVENS 20GN WITH SKYLINE/MAGISTAR TROLLEYS PNC 922771
- WATER INLET PRESSURE REDUCER PNC 922773
- Extension for condensation tube, 37cm PNC 922776
- Non-stick universal pan (12" x 20" x 1 1/2") PNC 925001
- Non-stick universal pan (12" x 20" x 2 1/2") PNC 925002
- Frying griddle double sided (ribbed/ smooth) 12" x 20" PNC 925003
- Aluminum combi oven grill (12" x 20") PNC 925004
- Egg fryer for 8 eggs (12" X 20") PNC 925005
- Flat baking tray with 2 edges (12" x 20") PNC 925006
- Potato baker GN 1/1 for 28 potatoes (12"X20") PNC 925008

Front

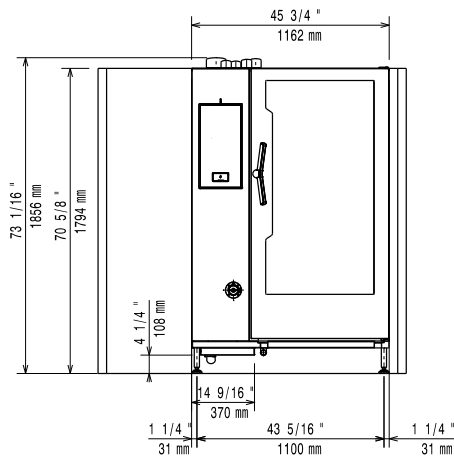

Side

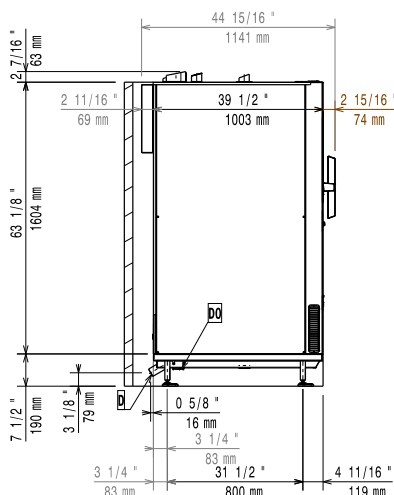

- CW11 = Cold Water inlet** **EI = Electrical connection**
CW12 = Cold Water Inlet 2 **G = Gas connection**
D = Drain
DO = Overflow drain pipe

Top

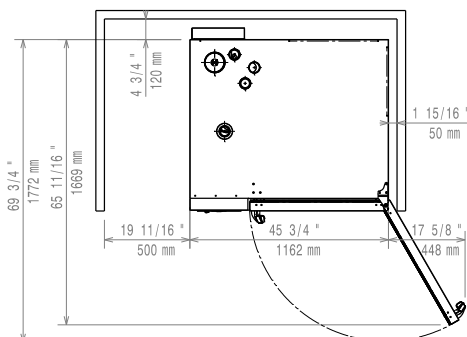

Electric

Supply voltage:	219785 (ECO202T300)	120 V/1 ph/60 Hz
Electrical power, default:		2.5 kW
Electrical power, max:		2.5 kW

Gas

Gas Power	401921 BTU/h
Standard gas delivery:	Natural Gas G20
Static Pressure:	< 10" WC
Dynamic Pressure:	7" WC
ISO 7/1 gas connection diameter:	1" MNPT

Electrolux Professional does not recommend the use of a GFCI outlet. If a GFCI outlet is required by code, a commercial GFCI with a trip rating of 20 mA must be used.

Water:

Water Cold Supply Connection:	3/4"
Cold Water Inlet Connection:	3/4" GHT
Pressure:	15-87 psi (1-6 bar)
Drain "D":	2" (50 mm)
Max inlet water supply temperature:	86°F (30°C)
Chlorides:	<17 ppm
Conductivity:	>50 µS/cm
Water inlet cold 1:	unfiltered
Water inlet cold 2:	filtered

Electrolux Professional recommends the use of treated water, based on the water specs listed. Refer to manual for details

Installation:

Clearance:	Clearance: 2 in (5 cm) rear and right hand sides.
Suggested clearance for service access:	20 in (50 cm) left hand side.

Capacity:

Max load capacity:	440 lbs (200 kg)
Full-size sheet pans:	20 - 18" X 26"

Key Information:

Door hinges:	
External dimensions, Width:	45 3/4" (1162 mm)
External dimensions, Depth:	42" (1066 mm)
External dimensions, Height:	70 5/8" (1794 mm)
Net weight:	909 lbs (412.5 kg)
Shipping width:	47 3/16" (1200 mm)
Shipping depth:	45 3/8" (1150 mm)
Shipping height:	79 1/32" (2010 mm)
Shipping weight:	1047 lbs (478 kg)
Shipping volume:	97.81 ft ³ (2.77 m ³)

ISO Certificates

ISO Standards:	ISO 9001; ISO 14001; ISO 45001; ISO 50001
-----------------------	---

Sustainability

Current consumption: 20.8 Amps