

## SkyLine ProS

### Electric Boilerless Combi Oven 61 208V

ITEM # \_\_\_\_\_

MODEL # \_\_\_\_\_

NAME # \_\_\_\_\_

SIS # \_\_\_\_\_

AIA # \_\_\_\_\_



219650 (ECO61K3L0)

SKYLINE ProS OVEN 6  
 HALF SHEET PANS (13" X  
 18") OR 6 HOTEL PANS (12  
 " X 20") TOUCH-ELECTRIC  
 208V -BOILERLESS

### Short Form Specification

#### Item No. \_\_\_\_\_

Combi oven with high resolution full touch screen interface, multilanguage, IPX5, ETL, EnergyStar, Ergocert

- BOILERLESS
- OptiFlow: air distribution system with 7 fan speed levels
- SkyClean: Automatic and built-in self cleaning system with integrated descale of the steam generator.
- 2 Cooking modes: Programs, Manual
- Special functions: MultiTimer cooking, Plan-n-Save, SkyHub homepage, agenda MyPlanner, automatic backup mode to avoid downtime
- USB port to download HACCP data, programs and settings. Connectivity to the cloud ready
- 6-point multi sensor core temperature probe
- Triple-glass door with double LED lights line
- Includes (3) 922062 stainless steel grids

### Main Features

- Instant steam generator: Boilerless steaming function to add and retain moisture for high quality, consistent cooking results. Automatic moistener (11 settings)
- Dry, hot convection cycle (77 °F - 575 °F/25°C - 300 °C): ideal for convection cooking.
- EcoDelta cooking: cooking with food probe maintaining preset temperature difference between the core of the food and the cooking chamber.
- Programs mode: a maximum of 1000 recipes can be stored in the oven's memory, to recreate the exact same recipe at any time. The recipes can be group in 16 different categories to better organize the menu. 16-step cooking programs also available.
- MultiTimer: Special feature to manage up to 20 different cooking cycles at the same time in the same cavity guaranteeing even cooking results. Up to 200 MultiTimer available programs
- Reversible Fan: 7 speed fan levels from 300 to 1500 RPM with reverse rotation for optimal evenness. Fan stops in less than 5 seconds when door is opened.
- Picture Management: upload full customized images of cooking cycles or food items
- Automatic cool-down and pre-heat function
- Different chemical options available: solid (phosphate-free), liquid (requires optional accessory).
- GreaseOut: predisposed for integrated grease drain and collection for safer operations (dedicated base as optional accessory).
- USB port: to download HACCP data, share cooking programs and configurations. USB port also allows to plug-in sous-vide probe (optional accessory).
- Back-up mode: self-diagnosis is automatically activated if a failure occurs to avoid downtime.
- 6-point multi sensor core temperature probe for maximum precision and food safety.
- Capacity: 6 half sheet/hotel pans.
- OptiFlow air distribution system to achieve maximum performance in chilling/heating evenness and temperature control thanks to a special design of the chamber.

### Construction

- Seamless hygienic internal chamber with all rounded corners for easy cleaning.
- 304 AISI stainless steel construction throughout.
- Front access to control board for easy service.
- IPX 5 spray water protection certification for easy cleaning.
- Supplied with 6 tray rack for hotel pans, 2 2/3" pitch (67 mm).
- Triple thermo-glazed door: with 2 hinged inside panels for easy cleaning and double LED lights line.

### User Interface & Data Management

- Touchscreen: High resolution interface (translated into more than 30 languages including Spanish and French) - color-blind friendly panel.

APPROVAL: \_\_\_\_\_



- Make-it-mine: feature to allow full personalization or locking of the user interface by selecting what is visible on screen
- SkyHub: customizable homepage to allow the user to group their favorite functions for immediate access when operating.
- MyPlanner: on-screen agenda where the user can plan their daily work, set reminders for several users and receive personalized alerts for each activity
- Connectivity: ready for real time access to connected appliances from remote and HACCP monitoring (requires optional accessory).
- e-learning: equipment trainings, how-to guides, and technical documentation easily accessible by scanning QR-Code with any mobile device.
- Data Analytics: automatic consumption visualization at the end of the cycle.

### Sustainability



- Human centered design: with 4-star certification for ergonomics and usability.
- Door handle: ergonomic wing-shaped design for hands-free door opening with elbow, to allow simple trays management (Registered Design at EPO).
- Reduced-Power Feature: To consume less energy during customized slow cooking cycles.
- SkyClean: Automatic self cleaning system with integrated descaling of the steam boiler. 5 automatic cycles (soft, medium, strong, extra strong, rinse-only) and green functions to save energy, water, detergent and rinse aid. Also programmable with delayed start.
- Plan-n-Save: the oven organizes the sequence of the chosen cooking cycles to optimize the processes in the kitchen reducing time and energy consumption.

### Included Accessories

- 3 of Single 304 stainless steel grid (12" x 20") PNC 922062

### Optional Accessories

- Caster kit for base for 61, 62, 101 and 102 oven bases only PNC 922003
- Pair of half size oven racks, type 304 stainless steel PNC 922017
- Chicken racks, pair (2) (fits 8 chickens per rack) PNC 922036
- Single 304 stainless steel grid (12" x 20") PNC 922062
- Stainless steel 304 grids (GN ½) with spikes, fits 4 chickens PNC 922086
- External side spray unit PNC 922171
- Baguette tray, made of perforated aluminum, silicon coated, 16" x 24" PNC 922189
- Perforated baking tray, made of perforated aluminum, 16" x 24" PNC 922190
- Baking tray, made of aluminum 16" x 24" PNC 922191
- Pair of frying baskets PNC 922239
- Pastry grid 16" x 24" PNC 922264
- Double-click closing catch for oven door PNC 922265
- Grid for whole chicken 1/IGN (8 per grid - 2.6 lbs each) PNC 922266
- USB Probe for sous-vide cooking (only for Touchline ovens) PNC 922281

- Grease collection tray (4") for 61 and 101 ovens PNC 922321
- Kit universal skewer rack & (4) long skewer ovens (TANDOOR) PNC 922324
- Universal skewer pan for ovens (TANDOOR) PNC 922326
- Skewers for ovens, (4) 24" long (TANDOOR) PNC 922327
- Smoker for ovens PNC 922338
- Multipurpose hook PNC 922348
- 4 FLANGED FEET FOR 61,62,101,102 OVENS - 2" 100-130MM PNC 922351
- Grid for 8 whole ducks (1.8KG, 4LBS) - GN 1/1 PNC 922362
- HOLDER FOR DETERGENT TANK - WALL MOUNTED PNC 922386
- USB SINGLE POINT PROBE PNC 922390
- 6 Tray Rack with wheels, Half Sheet Pans, 2 ½" (65mm) pitch for 61 ovens and blast chillers PNC 922600
- 5 Tray Rack with wheels, Half Sheet Pans, 3" (80mm) pitch, for 61 ovens and blast chillers PNC 922606
- Bakery/pastry tray rack with wheels 400x600mm for 6 GN 1/1 oven and blast chiller freezer, 80mm pitch (5 runners) PNC 922607
- Slide-in rack with handle for 61 and 101 combi oven PNC 922610
- Open base with tray support for 61 & 101 combi oven PNC 922612
- Cupboard base with tray support for 61 & 101 combi oven PNC 922614
- HOT CUPBOARD BASE WITH TRAY SUPPORT FOR 61 AND 101 OVEN HALF SHEET PANS (12" X 20") PNC 922615
- External connection kit for detergent and rinse aid PNC 922618
- Grease collection kit for 61,62,101,102 cupboard base (trolley with 2 tanks, open/close device and drain) PNC 922619
- Stacking kit for electric 61/61 combi ovens or electric 61/101 combi ovens PNC 922620
- Trolley for slide-in rack for 61 and 101 combi oven and blast chiller freezer PNC 922626
- Trolley for mobile rack for 2 stacked 61 combi ovens on riser PNC 922628
- Trolley for mobile rack for 61 on 61 or 101 combi ovens PNC 922630
- RISER ON FEET FOR STACKED 2X6 GN 1/1 OVENS OR 6 GN 1/1 OVEN ON BASE PNC 922632
- Riser on wheels for 2 stacked 61 combi ovens, height=250mm (9 6/7in) PNC 922635
- Stainless steel drain kit for all oven sizes (61, 62, 101,102, 201,202)- dia=50mm (2") PNC 922636
- Plastic drain kit for all oven sizes (61, 62, 101,102,201, 202), dia=50mm (2") PNC 922637
- Trolley with 2 tanks for grease collection PNC 922638
- Grease collection kit for open base (2 tanks, open/close device and drain) PNC 922639
- Wall support for 61 oven PNC 922643
- Dehydration tray, (12" x 20"), H=2/3" PNC 922651



- Flat dehydration tray, (12" x 20") PNC 922652
- Bakery/pastry rack kit for 6 GN 1/1 oven with 5 racks 400x600mm and 80mm pitch PNC 922655
- Stacking kit for gas 6 GN 1/1 oven placed on 7kg and 15kg crosswise blast chiller freezer PNC 922657
- Heat shield for stacked ovens 61 on 61 combi ovens PNC 922660
- Heat shield for stacked ovens 61 on 101 combi ovens PNC 922661
- Heat shield for 61 combi oven PNC 922662
- Compatibility kit for installation of 61 Skyline electric combi oven on previous generation 61 electric combi oven PNC 922679
- Fixed tray rack for 6 GN 1/1 and 400x600mm grids PNC 922684
- Kit to fix oven to the wall PNC 922687
- Tray support for 61 & 101 oven base PNC 922690
- 4 adjustable feet with black cover for 61,62 & 101,102 combi ovens, 150-200mm (5 9/10in -7 9/1in) PNC 922693
- Detergent tank holder for open base PNC 922699
- Bakery/pastry runners 400x600mm for 6 & 10 GN 1/1 oven base PNC 922702
- Wheels for stacked ovens PNC 922704
- Mesh grilling grid (12" x 20") PNC 922713
- Probe holder for liquids PNC 922714
- Fixed tray rack, 61 combi oven, h=85mm (3 1/3") PNC 922740
- 4 high adjustable feet for 61,62 & 101,102 combi ovens, 230-290mm (9in - 11 2/5in) PNC 922745
- Tray for traditional static cooking, H=100mm (12" x 20") PNC 922746
- Double-face griddle, one side ribbed and one side smooth, 400x600mm PNC 922747
- TROLLEY FOR GREASE COLLECTION KIT PNC 922752
- WATER INLET PRESSURE REDUCER PNC 922773
- KIT FOR INSTALLATION OF ELECTRIC POWER PEAK MANAGEMENT SYSTEM-6-10 GN OVENS PNC 922774
- Extension for condensation tube, 37cm PNC 922776
- Non-stick universal pan (12" x 20" x 3/4") PNC 925000
- Non-stick universal pan (12" x 20" x 1 1/2") PNC 925001
- Non-stick universal pan (12" x 20" x 2 1/2") PNC 925002
- Frying griddle double sided (ribbed/smooth) 12" x 20" PNC 925003
- Aluminum combi oven grill (12" x 20") PNC 925004
- Egg fryer for 8 eggs (12" X 20") PNC 925005
- Flat baking tray with 2 edges (12" x 20") PNC 925006
- Baking tray for (4) baguettes (12" x 20") PNC 925007
- Potato baker GN 1/1 for 28 potatoes (12"X20") PNC 925008
- Non-stick U-pan (12" x 10" x 3/4") PNC 925009
- Non-stick U-pan (12" x 10" x 1 1/2") PNC 925010
- Non-stick U-pan (12" x 10" x 2 1/2") PNC 925011
- Compatibility kit for installation on previous base 61,101 PNC 930217

Front

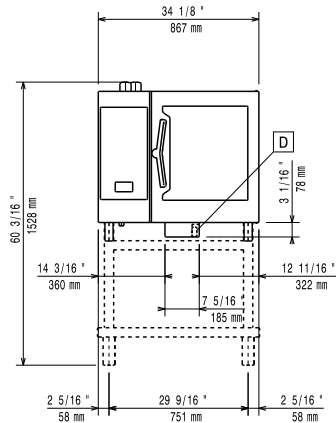

Side

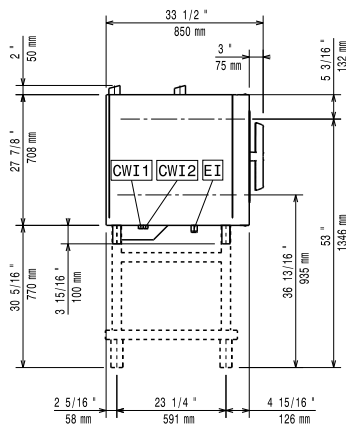

CWI1 = Cold Water inlet      EI = Electrical connection

CWI2 = Cold Water Inlet 2

D = Drain

DO = Overflow drain pipe

Top

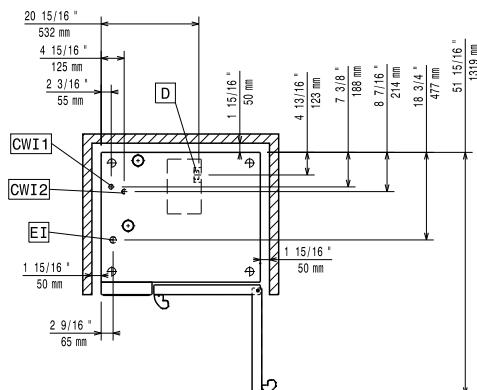

### Electric

<b>Supply voltage:</b>	219650 (ECO61K3L0)	208 V/3 ph/60 Hz
<b>Electrical power, default:</b>		11.1 kW
<b>Electrical power, max:</b>		11.1 kW

### Water:

<b>Water Cold Supply Connection:</b>	3/4"
<b>Cold Water Inlet Connection:</b>	3/4" GHT
<b>Pressure:</b>	15-87 psi (1-6 bar)
<b>Drain "D":</b>	2" (50 mm)
<b>Max inlet water supply temperature:</b>	86°F (30°C)
<b>Chlorides:</b>	<10 ppm
<b>Conductivity:</b>	>50 µS/cm
<b>Water inlet cold 1:</b>	unfiltered
<b>Water inlet cold 2:</b>	filtered

**Electrolux Professional** recommends the use of treated water, based on testing of specific water conditions. Refer to manual for details

### Installation:

<b>Clearance:</b>	Clearance: 2 in (5 cm) rear and right hand sides.
<b>Suggested clearance for service access:</b>	20 in (50 cm) left hand side.

### Capacity:

<b>Max load capacity:</b>	66 lbs (30 kg)
<b>Hotel pans:</b>	6 - 12" X 20"
<b>Half-size sheet pans:</b>	6 - 13" X 18"

### Key Information:

<b>Door hinges:</b>	
<b>External dimensions, Width:</b>	34 1/8" (867 mm)
<b>External dimensions, Depth:</b>	30 1/2" (775 mm)
<b>External dimensions, Height:</b>	31 13/16" (808 mm)
<b>Net weight:</b>	255 lbs (115.5 kg)
<b>Shipping width:</b>	36 5/8" (930 mm)
<b>Shipping depth:</b>	36 5/8" (930 mm)
<b>Shipping height:</b>	40 9/16" (1030 mm)
<b>Shipping weight:</b>	292 lbs (132.5 kg)
<b>Shipping volume:</b>	31.46 ft <sup>3</sup> (0.89 m <sup>3</sup> )

### ISO Certificates

<b>ISO Standards:</b>	ISO 9001; ISO 14001; ISO 45001; ISO 50001
-----------------------	---

### Sustainability

<b>Current consumption:</b>	31.9 Amps
-----------------------------	-----------