

Item # _____

Qty # _____

Model # _____

Project # _____



DUKERS

Quality Commercial Refrigeration



HOT PLATE FOUR BURNER DCHPA24



Catch Tray



Surface



Legs



PRODUCT DESCRIPTION

- ✦ Stainless steel exterior and interior.
- 🔥 28,000 BTU stainless steel burners with standby pilot.
- 🍳 Lift-off cast iron burner.
- 📏 Independent manual controls every 12".
- ❄️ "Cool-to-the-touch" front s/s edge.
- 🌡️ Each hot plate is shipped with Standard Natural Gas, LP conversion kit.
- 📏 Adjustable, stainless steel legs standard.
- 🧼 Full length seamless drip pan, easy to remove and clean.



HIGH QUALITY STAINLESS STEEL & ROBUST DESIGN

HOT PLATE
MODEL

DCHPA24

DIMENSION

Width	Depth	Height
24 in	28 3/4 in	13 3/8 in



DUKERS

Los Angeles | San Francisco | Dallas
Houston | Florida | Chicago | New Jersey

1-800-931-8628

@ info@dukersusa.com

www.DukersUSA.com

DETAILS & SPECIFICATIONS

HOT PLATE DCHPA24

Top View

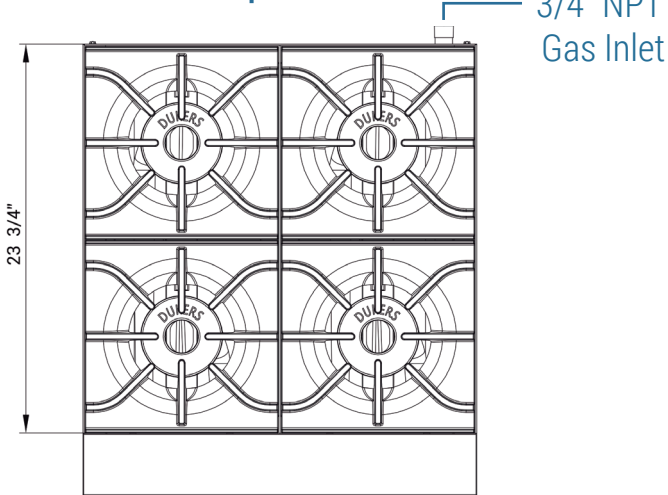

Side View

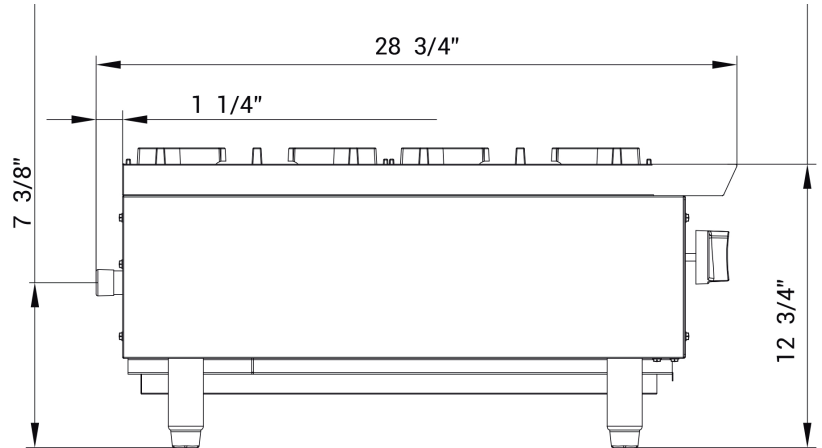

Front View

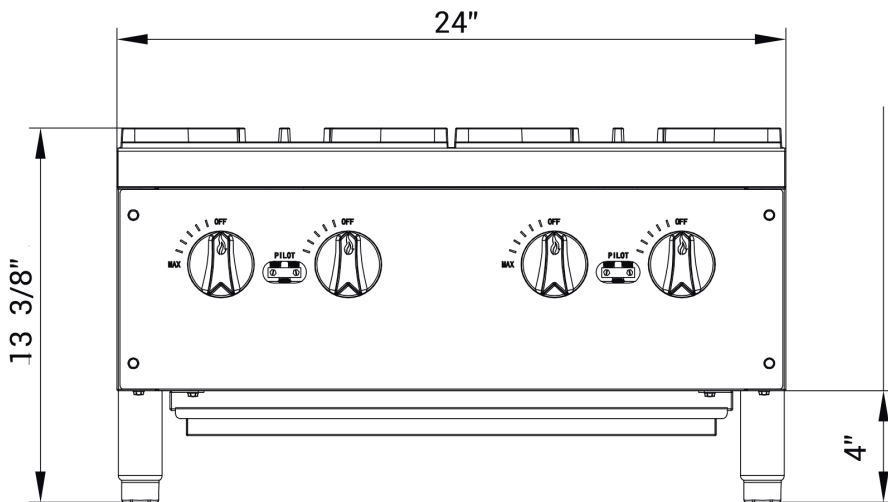

DCHPA24

GAS SOURCE	NG/Propane
WORK AREA	23.82x23.62in
BURNER	4 count
SINGLE BURNER	28000 BTU/H
COMBINED	112000 BTU/H
GAS PRESSURE	NG: 4 "WC Propane: 10 "WC
NOZZEL	NG: 40# Propane: 52#
CONTAINER FITMENT	255



Model	Packaging Dimensions (inches)			Net Weight (lbs)	Ship Weight (lbs)
	W	D	H		
DCHPA24	26 1/8"	32 5/8"	17 3/4"	110.23	143.3



Los Angeles | San Francisco | Dallas
Houston | Florida | Chicago | New Jersey

1-800-931-8628

@ info@dukersusa.com

www.DukersUSA.com