

Cheesemelter / Salamander Broiler

Standard Features

- Durable stainless steel structure, corrosion-resistant and easy to clean
- Simple and reasonable structure, easy to manipulate and maintain
- High efficient Ceramic infrared burner, for quick and even heating, standby pilots
- Independent manual controls to save the energy
- Mounting kits available to save kitchen space



ATSB-36



Specifications

Model	Burners and Control Method	Gas type	"Intake-tube pressure (in. W.C.)"	PerBTU B.T.U./h	Total BTU B.T.U./h	Regulator	"Netweight (LBS)	Packing Demension (Inch)	"Gross weight (LBS)"
ATSB-36	2 Burners Independent Manual Control	NG	5	21,500	43,000	s.w.c.	144.4	40 x 24.6 x 25.4	169.8
		LP	10	21,500	43,000	10" w.c.			



1 YEAR PARTS AND LABOR WARRANTY(US ONLY)



Plan View

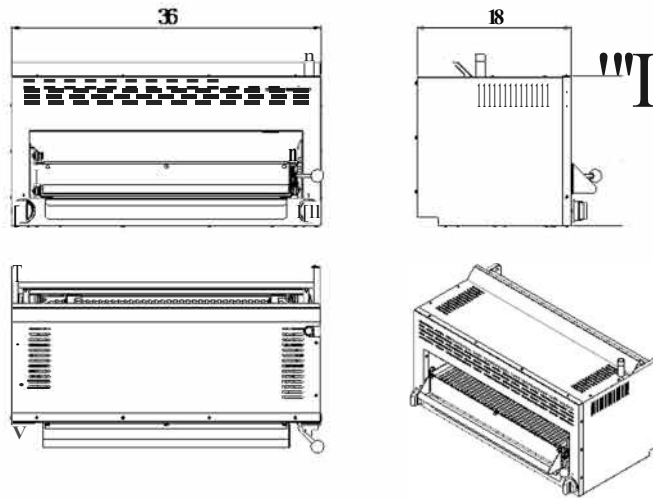

ATSB-36

Tenns and Conditions

1 YEAR WARRANTY

All claims for parts or labor must be made directly to Atosa. All claims must include: model number of the unit, serial number, proof of purchase, date of installation, and all pertinent information supporting the alleged defect. Failure to comply with warranty policies will result in voiding claims.

Atosa warrants all new gas components to be free from defects in materials or workmanship. Atosa's obligation under this warranty is limited to a period of 1 year from the original installation. All parts covered under this warranty that are defective within 1 year of the original installation are limited to repair or replacement (including labor charges, of defective parts or assemblies) The labor warranty shall include standard straight time labor charges only and reasonable travel time, as determined by Atosa.

NO CONSEQUENTIAL DAMAGES: ATOSA IS NOT RESPONSIBLE FOR ECONOMIC LOSS; PROFIT LOSS; OR SPECIAL, INDIRECT, OR CONSEQUENTIAL DAMAGES, INCLUDING WITHOUT LIMITATION, LOSSES, OR DAMAGES ARISING FROM FOOD OR PRODUCT SPOILAGE, REGARDLESS OF WHETHER OR NOT THEY RESULT FROM REFRIGERATION FAILURE.

WARRANTY IS NOT TRANSFERABLE: This warranty is not assignable and applies only in favor of the original purchaser/user to whom delivered. ANY SUCH ASSIGNMENT OR TRANSFER SHALL VOID THE WARRANNTIES HEREIN AND SHALL VOID ALL WARRANTIES, EXPRESS OR IMPLIED, INCLUDING ANY WARRANTY OF MERCHANTABILITY OR LABOR COVERAGE FOR COMPONENT FAILURE OR OTHER THE WARRANTY PACKET PROVIDED WITH THE UNIT.

ALTERATION, NEGLIGENCE, ABUSE, MISUSE, ACCIDENT, DAMAGE DURING TRANSIT OR INSTALLATION, FIRE, FLOOD, OR ACTS OF GOD: Atosa is not responsible for the repair or replacement of any parts that are determined to have been subjected after the date of manufacture to alteration, neglect, abuse, misuse, accident, damage during transit or installation, fire, flood, or acts of God.

WHAT IS WARRANTED AND FOR HOW LONG:

The Product's cast-iron grates, stainless steel radiants, and briquettes are warranted not to fail as a result of defects in materials or workmanship in normal use for a period of one year from the date of purchase. Atosa agrees to repair or replace, at its option, the above warranted parts or items that fails due to defects in materials or workmanship during the warranted period. To obtain warranty service, the Purchaser must contact Atosa toll free (855) 855-0399

THE ONE YEAR PARTS & LABOR WARRANTY ARE AS DESCRIBED ABOVE. THESE WARRANTIES ARE EXCLUSIVE AND IN LIEU OF ALL OTHER WARRANTIES, INCLUDING IMPLIED WARRANTY AND MERCHANTABILITY OR FITNESS FOR A PARTICULAR PURPOSE. THERE ARE NO WARRANTIES WHICH EXTEND BEYOND THE DESCRIPTION ON THE FACE HEREOF.

Outside U.S. and Canada: This warranty does not apply to areas outside the continent of the United States. Atosa is not responsible for any warranty claims made on products sold or used in such areas.

In some cases, a 25% restocking fee may be charged to a buyer for returned items.