

USER MANUAL

COUNTERTOP ELECTRIC DEEP FRYER



MODEL: DF15-1-120, DF15-2-120



USR Brands, Inc.

Phone: 800-764-1172 | www.usrestaurant.com | sales@usrestaurant.com

Thank you for purchasing and using DF series Electric Fryer. In order to making full use of functions of this product and minimize unnecessary loss and damage, please read the manual carefully and keep it for future reference.

WARNING!

ANY REFITTING AND WRONG INSTALLATION, ADJUSTMENT AND MAINTENANCE CAN LEAD TO PROPERTY LOSS AND CASUALTY.

PLEASE CONTACT THE SUPPLIER IF YOU NEED TO AJDUST OR MAINTAIN IT AND ALL THESE SHOULD BE DONE BY AUTHORIZED PROFESSIONALS.

WARNING!

DO NOT PUT FLAMMABLE LIQUID, GAS OR OTHER OBJECT AROUND THE PRODUCT FOR YOUR SAFETY SAKE.

WARNING!

THE SHEEL OF THIS MACHINE MUST BE GROUNDED FOR SAFETY SAKE. IF THE OIL LEVEL IS BELOW THE MINIMUM INDICATED LEVEL WILL CAUSE A FIRE.

THANK YOU FOR YOUR COOPERATION!

The design of this product is new and function is stale. It has features of beautiful appearance, reasonable structure, easy operation, constant temperature control, fast heating and saving oil and energy. It can cook, fry and warm food. It is an ideal assistant and first choice for cooking.

A. Structure

DF series 1-tank electric fryer

DF series 2-tank electric fryer

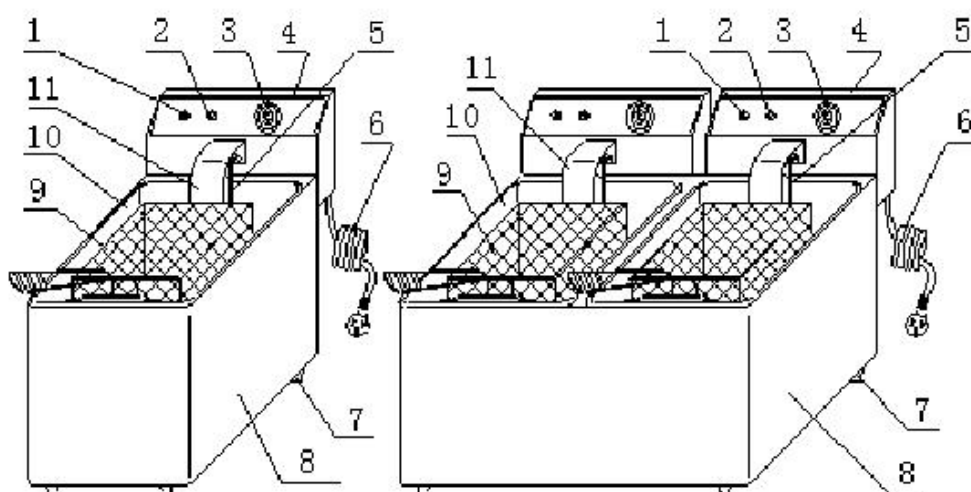

1-POWER INDICATOR

2-HEATING INDICATOR

3-TEMPERATURE CONTROLLER

4-ELECTRIC BOX

5-ELECTRIC HEATING TUBE

6-POWER CABLE

7-RUBBER FOOT

8-LOWER BOX

9-FRYING BSSKET

10-OIL POT

12-PROTECTING BOARD FOR ELECTRIC HEATING TUBE

B. FUNCTION

- DF series electric fryer has two kinds. One is 1-tank fryer; another is 2-tank fryer. 2-tank fryer can fry two different kind of food in case of

mixing the smell.

2. There is thermostat in it and it can set temperature for frying. Power indicator and heating indicator can show the heating situation.
3. When temperature of oil is over the limited temperature, the protecting device for limiting temperature can cut off power automatically. It can avoid being over temperature (reset the device by hand).
4. When lifting the electric box, the micro-switch works at once. It cut off power to make sure personal safety and in case of electric heating tube being dry burned.
5. The handle of frying basket can be folded and dismantled. It has a stainless steel moving oil tank with calibration mark of oil level. It is easy to be operated, cleaned, transported and stored.
6. Electric heating tube has protecting board and it can be easy to draw out of bottom box with the electric box and separate from oil pot. Then it is easy to clean electric heating tube and oil pot.

C. Basic parameter

Name	1-Tank Electric Fryer
Model	DF15-1-120
Voltage	120V, 60Hz
Power	1750W
Number of oil pot	1
Size of oil pot	9.5"L x 12"D x 6"H
Oil Capacity	15 lb.
Number of frying basket	1
Size of frying basket	3.5"L x 8.3"D x 4.3"H
The setting range of temperature of oil	122°F~374°F
Moving temperature of temperature limiter	446°F
Hand resisting temperature	<302°F
Dimension	10.4"L x 16.9"D x 11.6"H
Length of handle(mm)	240
Weight	12 lb.

Name	2-Tank Electric Fryer
Model	DF15-2-120
Voltage	120V, 60Hz
Power	2x1750W
Number of oil pot	2
Size of oil pot	9.5"L x 12"D x 6"H
Volume	2*15 lb.
Number of frying basket	2
Size of frying basket	3.5"L x 8.3"D x 4.3"H
The setting range of temperature of oil	122°F~374°F
Moving temperature of temperature limiter	446°F
Hand resisting temperature	<302°F
Dimension	21.7"L x 16.9"D x 11.6"H
Length of handle(mm)	240
Weight	24 lb.

THE QUANTITY OF FOOD FOR COOKING IN ONE TIME, ACCORDING TO MEET, IT SHOULD NOT BE OVER THE NEXT DATA.

DF15-1-120/DF15-2-120

0.9Kg/pot

NOTE

- ① THE QUANTITY OF FOOD WHICH IS NOT MEAT MUST BE LIMITED IN ORDER TO AVOID OIL OVERFLOWING.
- ② TO FRY FOOD WHICH IS TOO WET AND ADD TOO MUCH FOR ONE TIME WILL CAUSE OIL BE OVERBOILING.
- ③ ACCORDING TO NORMAL VOLUME TO ADD FOOD INTO EACH FRYER.
- ④ OVER-WET AND TOO LARGE FOOD WILL EFFECT THE SURGE OF BOILING OF OIL.

D. Circuit diagram

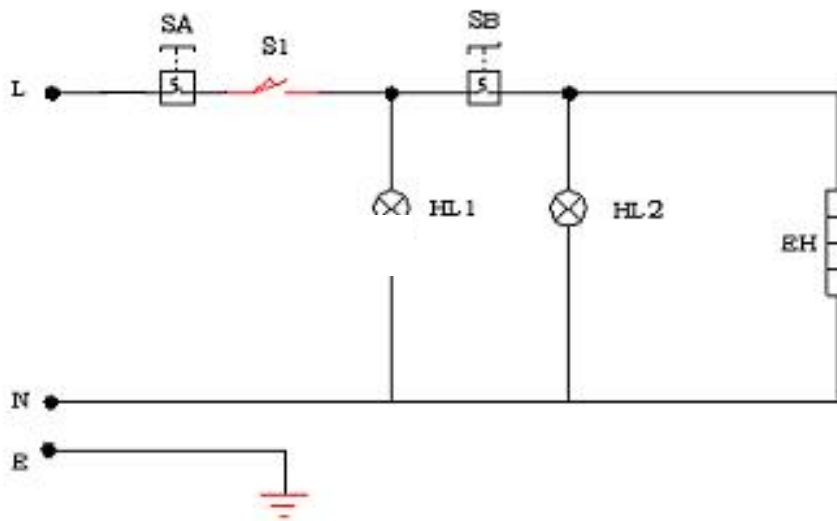

S1—MICRO-SWITCH SA—TEMPERATURE LIMITER

EH—ELECTRIC HEATING TUBE HL1—POWER INDICATOR

HL2—HEATING INDICATOR E—EARTH GROUND

SB—TEMPERATURE CONTROLLER

NOTE: THE CIRCUIT PRINCIPLE OF DF SERIES 1-TANK/2-TANK ELECTRIC FRYER IS DIFFERENT. THE DIFFERENCE IS ARE THAT 2-TANK ELECTRIC FRYER HAS TWO

TANKS AND TWO ELECTRIC BOXES AND TWO SEPARATE TEMPERATURE CONTROLLER.

E. Instruction

1. Check if the installation of power supply is normal, and make sure the supplied voltage is coordinated with the using voltage.
2. There is oil level mark in the internal oil pot, when using the quantity of oil in oil pot should be kept in certain level. "MAX" shows the most volume of oil, "MIN" shows the less volume of oil. When using user can adjust the volume of oil according to user's need.
3. 1) Plug the machine and get through power supply, green indicator is on. At that time current has been supplied to the machine.
2) Rotate the temperature controller clockwise; put the needed temperature degree to the red point. At that time, the yellow indicator is on and green indicator is off. It shows that electric heating tube stops working and temperature of oil in pot is rising.
4. 1) When temperature of oil rises to the setting temperature, temperature controller can cut off power automatically.
2) When temperature of oil lowers, temperature controller can get through power automatically. Yellow indicator is on and green indicator is off, electric heating tube works again and temperature of oil rises.
3) It repeats again and again to make sure temperature of oil is constant in the setting temperature.
5. The cover of pot is designed for keeping the pot be cleaning and

- warming. When putting in on the cover, please make sure there is not water on it in case of water drops into pot and oil splashes.
6. 1) The enclosed frying basket for frying small food. There is hook and handle on the basket.
2) Soak the basket into oil when operating. When the frying is finished, lift the basket and hand it in the front notch of pot to filter oil. User can put big food into pot to fry.
 7. After working, please rotate the temperature controller counter-clockwise to the limit position and cut off power for safety sake.
 8. 1) Please pour the old oil out of pot when temperature of oil lowers to normal.
2) First, cut off power, then take the partition board for oil out of pot, and then take the electric box out of the back notch in bottom box. Electric heating tube and electric box are separate from pot, and put them on a clear place, then take out oil pot to clean.
 9. In order to make sure the stove is safe and durable. User should clean dreg of oil pot and filth of electric heating tube in order to keep the oil pot and electric heating tube is clean.
 10. The partition board of oil pot is designed for protecting electric heating tube. Put the partition board into the oil pot when frying food.
 11. 1) There is temperature in electric box. The moving temperature is 446°F; reset temperature is less 338°F.

- 2) There is “reset button for over heating” out of the shell. When temperature is over, the protecting button works. Press the reset button to restart.
12. There is micro-limit switch in the electric box. When put electric box into bottom box electricity get to the electric box; take it out then power is off.
13. Please use fresh vegetable oil in case of over boiling. Do not use old oil because it will have a reduced flash-point and be more prone to surge boiling.

F. Notes for installation

1. The using voltage for this equipment must be coordinated with the supplied voltage.
2. User should install a suitable power switch and breaker switch near the fryer.
3. At the back of the equipment is the earth bolt. Please connect the earth wire in compliance with the safety regulations reliably with copper cable of no less than 2mm².
4. Before using, check whether every connection is formed, voltage is normal and ground connection is safe.
5. Do not use water to clean the electric box directly.
6. The installation of this stove must be done by professionals.

Notice

- This equipment must be operated by trained cook or professionals.

- Do not refit it! The refitment of this product will cause serious accident.

- Do not clean the product with a water jet or soak electric box into water while cleaning.

Water can conduct electricity so the product may cause electric-shock accident by electric leakage.

- High temperature will cause scald. When fire-facing oven is in use and before or after being used, do not touch directly body of trunk and chamber of top truck because of high temperature.

- Do not use another power supply with different voltage.

Do not use main switch that is not coordinated with safety regulation.

- When thunder and lightning is closing, user should shut off main switch to avoid appliance being damaged by lightning strike.

- Do not use hard and sharp object to destroy the surface of oven body and the surface of oil pot.

- After using, please shut off main switch

- The installation and maintenance of electric circuit by professionals.

●If power cord is damaged, for preventing from danger, user should ask manufacturer or maintenance department or specific professionals to change it.

Warning!

- When using, hand, plug and switch must be dry.
- Oil should not be lower than the less oil level. Do not dry burn.
- Do not use water to clean the electric box directly or soak the electric box into water to clean.
- Do not use old oil to fry because it will cause over boiling.
- To fry over wet food and over add for one time will cause accident.

G. Troubleshooting

Troubles	Causes	Solution
1. Plug the machine and get through power supply, power indicator is not on and heat.	1. Plug is not inserted well. 2. Micro-switch contacts not well.	1. Remove the plug. 2. Adjust the limit distance of micro-switch
2. Heating indicator is not on and temperature is not raised.	1. Connection of electric heating tube is loosened.	1. Firm two sides of electric heating tube and screw. 2. Change electric heating tube.
3. Power indicator is on but the setting temperature is not raised.	1. Temperature controller is burned.	1. Change temperature controller.
4. Temperature control is normal but indicator is not on.	1. Indicator is burned.	1. Change indicator.
5. After circuit heating electric heating tube is not heated.	1. Temperature limiter works.	1. Reset "over heating protecting button" by hand.
6. Temperature control can not be controlled.	1. Temperature limiter is out of order.	1. Change temperature limiter.

Aforementioned troubles are just for reference. If any fault occurs, please cease using, return it to professional technicians for check and repair.

H. Transportation and storage

During transportation, the machine should be careful handled and prevent from shaking. The packaged machine should not be stored in the open air. It should be put in a ventilated warehouse without corrosive gas. It should not be put upside down. If it needs to be stored in open air temporary, measurement against raining in needed.

I. Cleaning and maintenance

1. Cut off the power supply before cleaning in case of accident.
2. Do not use wet towel with non-corrosive cleanser to clean the module plate, the surface of the equipment and power cord. Direct wash by water is not permitted in case of any damage of the functions.
3. If do not use it at any time, please turn off temperature controller and main switch.
4. Please store the equipment in a ventilated storehouse without corrosive gas after cleaning when ceasing its work for a long time.

J. Daily check

Notice the situation of the machine before or after using.

Before using	Whether the machine is tilted?
	Whether the power cord is old, broken or damaged?
	Whether the control panel is damaged?
After using	Whether there is strange smell?
	Whether the upper and lower module plate cannot be heated at the same time?
	Is there any strange voice or is the machine out of control while the machine is lifting?

WARNING!

- **Must check the machine everyday.**
Usually check the product that can avoid serious accident happens.
The temperature around the machine should not over 572°F.
- **Stop using if user feels that there are some problems in the circuit or machine.**
Ask the special technicians to check and maintain the machine as soon as possible.

K. Solid diagram

DF series 1-tank electric fryer

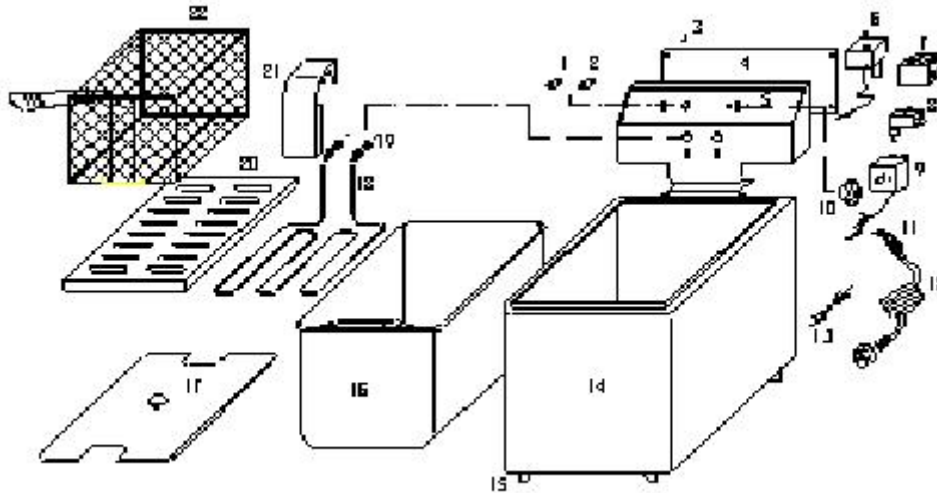

DF series 2-tank electric fryer

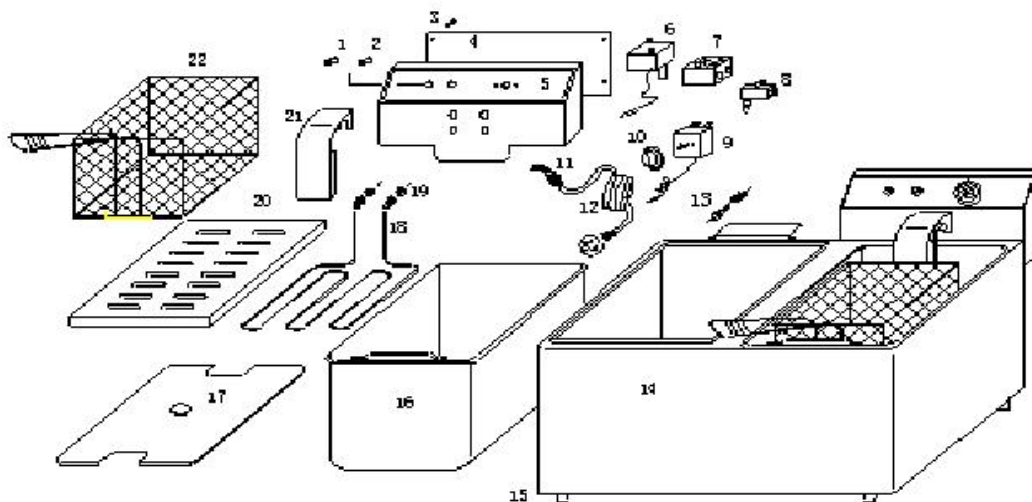

- | | | | |
|-----------------------------------|---------------------------|------------------------------------|--------------|
| 1— POWER INDICATOR | 2—HEATING INDICATOR | 3—SCREW OF SIDE BOARD | 4— |
| BACK BOARD | 5— ELECTRIC BOX | 6— TEMPERATURE LIMITER | 7— PORCELAIN |
| SOCKET FOR CONNECTION | 8— MICRO-SWITCH | | |
| 10— KNOB | 11— THEATH OF POWER CABLE | 12— POWER CABLE | |
| 13 — EQUIPOTENTIAL GROUNDED SCREW | 14 — LOWER BOX | 15 — RUBBER FEET | |
| 16— OIL POT | 17— COVER OF OIL POT | 18— ELECTRIC HEATING TUBE | 19— FIRMED |
| SCREW | 20 — PARTITION BOARD | 21 — PROTECTING BOARD FOR ELECTRIC | |
| HEATING TUBE | 22— FRYING BASKET | | |

L. LIST OF SOLID DIAGRAM

Name of product: DF series 1-tank fryer

NO	NAME	SPITICATION	AMOUNT	NOTE
1	Power indicator	Φ12 250V/14A	1	Outsourcing, green with line
2	Heating indicator	Φ12 250V/14A	1	Outsourcing, green with line
3	Fix screw for back board	M4×8 with flat pat	4	Outsourcing
4	Back board	Stainless S=0.8	1	
5	Electric box	Stainless S=0.8	1	
6	Temperature limiter	446°F/250V	1	Outsourcing
7	Connection ceramic	Insulated ceramic 250V/16A	1	
8	Micro-switch	KW-7-0/16A	1	Outsourcing
9	Temperature controller	374°F/250V	1	Outsourcing
10	Knob of temperature controller	ABS Plastic	1	
11	Sheath of power cable	Φ15/ABS Plastic	1	With bayonet
12	Power cable	250V 3×1.5mm ²	1	Outsourcing, with plug (> 2.5m)
13	Equipotential ground screw	M6×15/brass	1	With screw and spring, flat pat
14	Bottom box	Stainless S=0.8	1	
15	Rubber feet	Φ30×15/black	4	Outsourcing
16	Oil pot	Stainless steel	1	Outsourcing, with oil level
17	Cover of oil pot	Stainless S=0.8	1	
18	Electric heating tube		1	Out-processing
19	Fix screw for electric heating tube	45# steel M12	2	
20	Partition board for oil	Stainless S=0.8	1	
21	Protecting board for electric heating tube	Stainless S=0.8	1	
22	Frying basket	Stainless wire, net	1	Handle can be folded

Declare:

The specification of each electric heating tube in fryer is:

① DF15-1-120: 1750W, 120V/60Hz

M.LIST OF SOLID DIAGRAM

Name of product: DF series 2-tank fryer

NO	NAME	SPITICATION	AMOUNT	NOTE
1	Power indicator	Φ12 250V/14A	2	Outsourcing, green with line
2	Heating indicator	Φ12 250V/14A	2	Outsourcing, green with line
3	Fix screw for back board	M4×8 with flat pat	8	Outsourcing
4	Back board	Stainless S=0.8	2	
5	Electric box	Stainless S=0.8	22	
6	Temperature limiter	446°F/250V	2	Outsourcing
7	Connection ceramic	Insulated ceramic 250V/16A	2	
8	Micro-switch	KW-7-0/16A	2	Outsourcing
9	Temperature controller	374°F/250V	2	Outsourcing
10	Knob of temperature controller	ABS Plastic	2	
11	Sheath of power cable	Φ15/ABS Plastic	2	With bayonet
12	Power cable	250V 3×1.5mm ²	2	Outsourcing, with plug (> 2.5m)
13	Equipotential ground screw	M6×15/brass	2	With screw and spring, flat pat
14	Bottom box	Stainless S=0.8	1	
15	Rubber feet	Φ30×15/black	4	Outsourcing
16	Oil pot	Stainless steel	2	Outsourcing, with oil level
17	Cover of oil pot	Stainless S=0.8	2	
18	Electric heating tube		2	Out-processing
19	Fix screw for electric heating tube	45# steel M12	4	
20	Partition board for oil	Stainless S=0.8	2	
21	Protecting board for electric heating tube	Stainless S=0.8	2	
22	Frying basket	Stainless wire, net	2	Handle can be folded

Declare:

① DF15-2-120: 1750W+1750W, 120V/60Hz