

USER MANUAL

HALF SIZE ELECTRIC COUNTERTOP CONVECTION OVEN



MODEL: CSD-1AE



USR Brands, Inc.

Phone: 800-764-1172 | www.usrestaurant.com | sales@usrestaurant.com

Dear Client & User,

Thank you for choosing our products. All the information and instructions in this manual take into account standard safety regulations, current levels of technical engineering as well as the expertise and experience we have developed over the years.

If the delivery consists of a special model, the actual scope of delivery may differ from the descriptions and illustrations in this manual. This is also the case for special orders or when the device has been modified in line with new technology. Should you have any questions, please contact the manufacturer.

For safety purpose and efficient operation, please read the manual carefully before any operation to the appliance, especially when starting up the device. Install the machine in accordance with this manual and the local related rules.

Please notice that this manual is not applicable for those who have physiological, perceptual or psychological barrier or disability, as well as those who are lack of necessary knowledge or experience, including children.

Note: Read the instruction manual carefully before using the device. The manufacturer does not accept liability for any damage or malfunction resulting from not following the instructions for use.

The instruction manual should be kept near the device, easily accessible for anyone wishing to work with or using it. We reserve the right to make technical changes for purposes of developing and improving the useful properties.



Warning

- Any self-modification, wrong installation, adjustment or maintenance can lead to property loss or casualty. Please contact the manufacturer for any adjustment or maintenance, and have the work done by a trained & qualified personnel.
- For your safety sake, please keep the machine away from any flammable or explosive liquid, gas and other object.
- The device is not intended for use by individuals (including children) with physical or mental disabilities, insufficient experience, and/or insufficient knowledge unless such persons are under the supervision of a person responsible for their safety or have received instructions regarding appropriate use of the device.
- Keep children away from the device.
- Preserve this manual safely. When passing on/selling the device to a third party, the manuals must be handed over along with the device. All users must operate the device complying with the user's manual and related safety guidelines.
- Do not store or use any inflammable or explosive gas, liquid or objects near the device.
- If this appliance is placed near walls, partitions or kitchen furniture and the like, it is advisable to make these facilities with non-combustible material, otherwise cover them with non-combustible heat-resistant material, and pay attention to fire prevention regulations.
- The device shell shall be grounded to ensure safety. Thanks for your cooperation!

Contents

1. Functional Introduction.....	1
2. Structure Diagram & Working Principle.....	1
3. Basic Features & Parameters.....	2
4. Precautions & Recommendations.....	3
5. Using Instructions.....	5
6. Routine Check.....	6
7. Cleaning & Maintenance.....	6
8. Failure Analysis & Trouble Shooting.....	7

1. Functional Introduction

These products of electric oven are designed under our research & development while absorbing the advantages of similar products at home and abroad. They are integrated with all the merits of attractive design, reasonable structure, and convenient operation, all stainless steel made, sturdy and durable, as well as easy maintenance. Temperature is controlled by thermostat so that it is adjustable according to the food requirements within certain range. All of their features make them the ideal and necessary equipments for hotels, supermarkets, western restaurants, fast food restaurants and the like.

2. Structure Diagram & Working Principle

2.1 Structure Diagram:

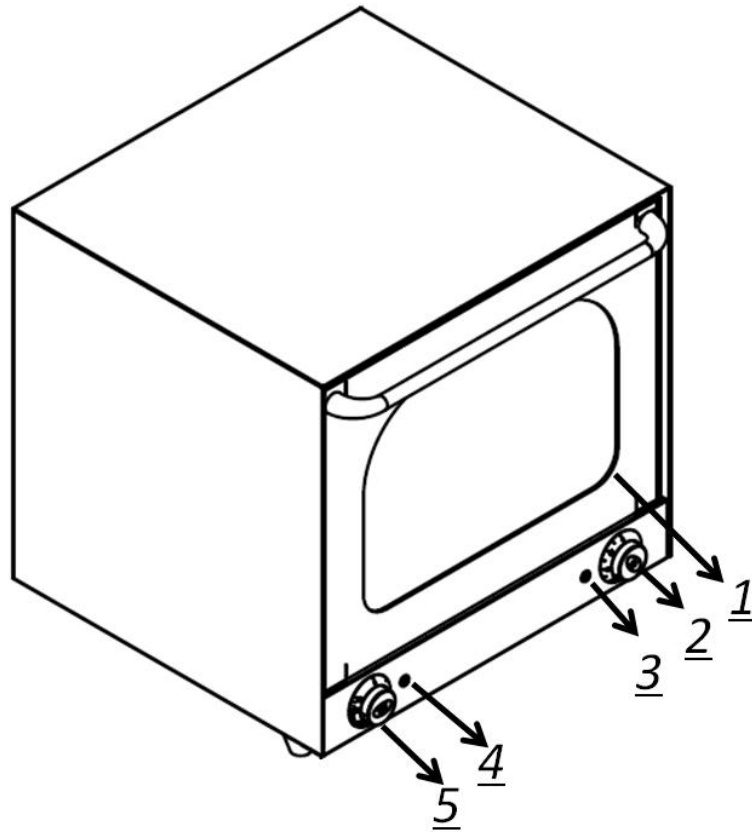

1. furnace body
2. temperature control

3. power indicator
4. timer indicator
5. timer control

2.2 Structural Performance Features

1. The outer surface is processed with smooth treatment, easy for clean and very health.
2. The temperature needed can be adjusted according to the needs.
3. Made of stainless steel material, with withdrawable s/s grid.
4. Heats up quickly, convenient operation and easy maintenance.

2.2 Electric Diagram:

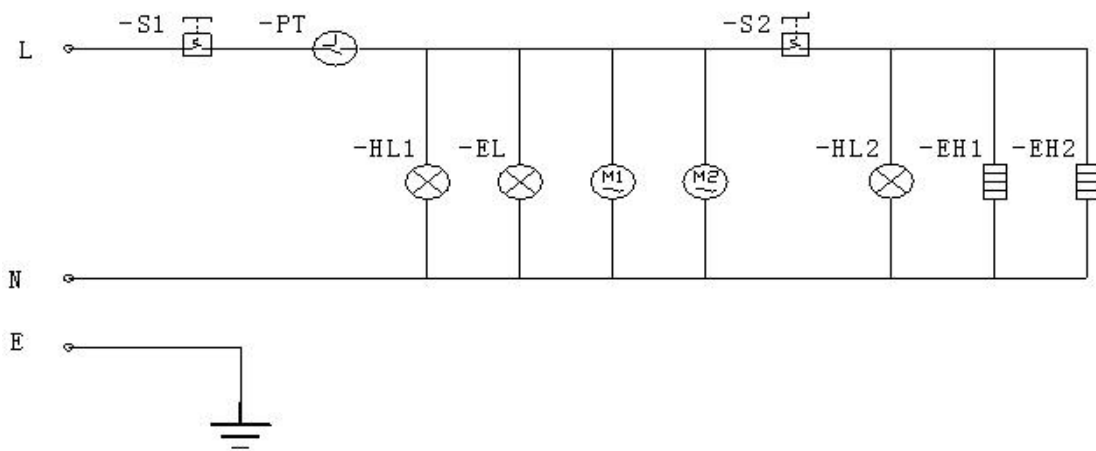

EH1---upper heating element
 EH2 ---main heating elements
 EL---internal light
 M1, M2---convection fans

S2---top heating element thermostat
 S1---fuse
 PT---timer
 HL1~HL2---probe lights

3. Basic Features & Parameters

Model	CSD-1AE
Dimension (in)	23.4"L x 20.9"D x 22.4"H
Voltage (V)	220-240
Power (W)	2670
Luminance (W)	30
Temperature Range	120°F to 570°F
Functions	Convection heater
Weight (lb)	84

4. Precautions & Recommendations

4.1 Transportation and Storage:

During transportation, please handle the appliance carefully and no upside down to prevent the damage of the enclosure and inner parts. Do not move this device alone or privately. When moving, please ask for help to avoid the oven falling down to the ground or cause unnecessary injuries. The packaged device should be stored in a well-ventilated warehouse of no corrosive gas. Should any temporarily storage needed, please take measurement against raining.

4.2 Notices for Installment:

Installation:

1. The Assembly of the Rubber Feet
 - The rubber feet must be mounted on the appliance. Do not use the oven without the rubber feet.
 - Fasten the rubber feet to the oven bottom with screws.
 - Adjust the oven height by the screw or unscrew the rubber feet directly.
2. The Place
 - Install this device on a flat and stable surface.
3. Remove the protection film.
4. Take out the trays in the oven and clean them.
5. Wipe the internal and external of the oven with wet cloth and then dry them with a soft cloth.
6. The Connection of Power Supply
 - Please make sure that the applicable power supply voltage and frequency comply with those indicated on the data plate prior to energize the device.
 - After installation of the oven, install a bipolar switch between the oven and the power grid so that the contact opening distance between them can be maintained at least 3mm and the input power is appropriate.
 - The oven shall be connected with the earth wire in the power grid.
 - The oven must be in a system of equipotential so that the power can be maintained the same as indicated on the data plate. Such connections can be only achieved among the labeled wire terminals of different appliances.
 - The minimum value of the equipotential conductor component is 10mm².
 - Connect the power cord to the power supply and ensure that the power cord is connected reliably and at a proper place.

Notice:

1. Make sure the connection of the power cord complies with the industrial standard.
2. The supply voltage should be in accordance with the working voltage of the device. The supplied voltage shall not exceed the voltage range by $\pm 10\%$, otherwise it may cause fire or electric shock when violating the industrial standard. If you are not sure about the specification of the voltage, please contact the manufacturer.
3. The device is equipped with grounding bolt at the back. It shall be reliably connected to ground wire that comply with the safety regulations with copper wire no less than 1.5mm^2 .
4. After installation, check the tightness of all the connection, the correct functioning of the voltage and the reliability of the ground wire.
5. Set the device on a flat, secure surface, and make the sides away from non-combustible material (e.g. Brick walls or windows) no less than 10 cm, and the rear at least 20 cm.
6. When installation, please ascertain that the device is far away from water or snow and it is advisable to place it near fire extinguisher. The main reason for causing electric shock and damages to the oven is the moist oven.
7. The installation must comply with the industrial standard. Incomplete installation may cause accidents like electric shock or water leakage.
8. The rubber feet must be mounted on the device reliably. The oven without rubber feet shall not be used.
9. According to the wiring regulation, the fixed wiring connected to this appliance must be equipped with an all-pole disconnect switch (leakage switch), with at least 3mm contact opening distance of each pole of the switch. It is also advised to install grounded leakage protection switch. Do not pile sundries in front of the switch for convenient operation.
10. The installation of this device shall be performed by trained technician.
11. Do not store any inflammable or explosive substances or volatile gases near the device. The ambient temperature shall be lower than 45°C (113°F) and the relative humidity shall be lower than 85%.

4.3 Special note

1. The appliance is a commercial machine which is not applicable for home use and should be operated by professional personnel.
2. No shaking or tilting during using.
3. Do not dismantle or modify the device, Serious accidents may happen when dismantling or modifying.
4. Do not open the appliance enclosure. The appliance contains high pressure electric circuit, electric shock may occur when dismantling the frame.
5. Unscrew the plug and cut off the power when cleaning.
6. Do not spray water directly to the product when cleaning. Water can conduct electricity, thus electric leakage may cause electric shock.

7. Do not pat the product and put heavy object onto the product. Abnormal operation may cause damage and danger.
8. High temperature may cause scald. Do not touch the appliance directly with hand due to high temperature during or after the operation.
9. When the thunderstorm is coming, cut off the power supply asap to avoid damage done by the lightning stroke.
10. Do not destroy the control panel with hard or sharp objects.
11. If someone gets burnt, please rinse the surface with cold water and then go to see the doctor immediately.
12. Please do not tread, extrude, bundle up or forcefully twist the power cord, otherwise the power cord may be damaged and cause fire or electric shock.
13. The oven is intended for baking cake, pie, poultry, beef, pork, break, steak and so on. Do not use it for other purposes.
14. Canned or bottled soda water cannot be heated in the oven, or the cans or bottles may explode and cause unnecessary injuries.
15. Disconnect it from power after working.
16. It would be dangerous for people other than qualified personnel to carry out the servicing work.
17. If the supply cord is damaged, to avoid danger, the substitution work should be done by the manufacturer, its maintenance department or similar professional personnel.

5. Using Instructions

1. The Usage of Timer
 - The number indicated by the time switch settled according to the needs of the food to be cooked is the time for cooking.
 - The cooking time can be set by rotating the timer clockwise. When the set time is up, you can hear a tick sound and the oven will close automatically.
 - During cooking, the oven can be turned off manually by just rotating the timer anticlockwise to the "0" position.
2. Convection Heater
 - Turn on the oven power supply
 - Set the temperature (120-570°F) you want
 - Rotate the time to the time (0-120min) needed. The temperature indicator, timer indicator and the internal light of the oven are all on.
 - When the temperature reaches the value you need, the power indicator will be off. If the temperature drops, the temperature indicator will be on again. This process will be repeated automatically.

Notice:

- Do not press down the button for long time

- The excess vapor will come out from the drainage pipe
- The function of “convection heater” and “top heating” can only be operated separately, which indicates that they cannot be used simultaneously.
- Do not operate any switches with wet hand, otherwise, it may cause electric shock easily
- During using the device, it is not allowed to place any objects onto the oven due to that the heat generated by the working oven can deform or damage the objects.
- Be careful to avoid burnings during or after using for a while
- During working, the metal accessories and glass door will get hotter and hotter, thus do not touch the door when opening or closing the door.
- The heat elements cannot be submerged in water. If water comes into the connection part of the heating elements, it may cause short circuit or other consequences.
- If there’s water in the chamber, do not pour out the water towards the glass door, or the glass door may break.
- When heating, please do not touch any part other than the handle and switches due to the hot body of the oven, or you may easily get burnt when you touch other parts. If the oven is submerged in water accidentally or the oven is in water for too long, all the electric components and wires shall be replaced, otherwise, it may be easy to catch fire or electric shock.
- Do not place heavy objects (120KG (280lb)) onto the oven. Or the oven may not operate normally or there may be other accidents.

6. Routine Check

It is necessary to check the machine daily.

Check the machine regularly can avoid serious accident happens.

Stop using if user feels that there are some problems in the circuit or machine.

Check the appliance every time before and after using:

Before using: Whether the machine is tilted?

Whether the control panel is damaged?

Whether the power cord is aged, broken or damaged?

During using: Whether there is strange smell, odour or vibration noise?

Whether the temperature is out of control or there’s leakage?

Whether the power is normal?

7. Cleaning & Maintenance

1. Disconnect power supply before any cleaning and maintenance to avoid electric shock.
2. Open the oven door and wait till it cools down (at least 10mins) before cleaning it.
3. Clean the chamber and storage place every day to maintain it clean.
4. Every day after working, wipe the furnace and power cord with wet towel which contains no corrosive detergent. Do not flush the device directly with water jet to avoid water to

- penetrate into the device and destroy its electric performance or cause electric shock.
5. Anytime when stop using, turn off its power supply and then bundle up the power cord and put it onto the oven body.
 6. If the device is out of use for a long time, it is advisable to clean it completely and then store it in a well ventilated warehouse without corrosive gas.

8. Failure Analysis & Trouble Shooting

Symptoms	Causes	Solutions
When connected to power, the heating indicator is on but it does not heat up.	<ol style="list-style-type: none"> 1. The thermostat is defeated 2. At least one of the heating elements is burnt out 	<ol style="list-style-type: none"> 1. Replace the thermostat 2. Replace the burnt out heating elements
When connected to power, rotate the thermostat, the heating indicator is on but the temperature rise is out of control	<ol style="list-style-type: none"> 1. the thermostat is defeated 	<ol style="list-style-type: none"> 1. replace the thermostat
When connected to power, it heats up normally, but the indicator is off	<ol style="list-style-type: none"> 1. the indicator is malfunctioning 	<ol style="list-style-type: none"> 1. Replace the indicator
Neither the indicator nor the heating elements work	<ol style="list-style-type: none"> 1. The power supply is abnormal and the device is not connected to power 2. The fuses is burnt out 	<ol style="list-style-type: none"> 1. check all the connections of the power cord to make it supply power normally 2. replace the fuse

Aforementioned troubles are just for reference. If any failure occurs, please stop using, and inform the professional technicians to check and repair.