

### Coldline LDCD-C Corner Deep Depth Refrigerated Meat Deli Case



#### FEATURES

- Deep depth refrigerated corner deli case
- Aligns to create L shape refrigerated display area
- Foamed with CFC-free polyurethane insulation
- Rear sliding tempered door allows easy access
- 16.7" deep shelf on top of canopy
- Bright interior LED lighting
- Easy to use digital controller
- 4 pre-installed low-profile casters, 4 leveling feet
- Uses eco-friendly R290 refrigerant
- Standard 110V plug and play
- Do not includes side panel, must connect with Coldline models LDCD

---

**U**SR Brands is a US supplier of premium quality commercial cooking, refrigeration and food preparation equipment. Our aim is simple. Produce industry-leading commercial restaurant equipment at reasonable prices, and back it all up with an easy to understand, no nonsense warranty that people can count on.

Project:	Quantity:
Model #:	Approval:

For Commercial Use Only

### TECHNICAL DATA

#### DIMENSIONS

Exterior Dimensions	53.15"L x 53.15"D x 47.24"H
Display Area	11.84 sq.ft
Packaging Dimensions	57.2"L x 57.2"D x 52.3"H
Unit Weight	452 lb.
Shipping Weight	606 lb.

#### ELECTRICAL

Voltage	115
Hertz	60
Phase	1
Amps	5.6
Plug Type	NEMA 5-15P
Power Cord Length	72"

#### COOLING

Temperature Range	33°F to 41°F
Refrigerant	R290
Max. Ambient Temp	77°F
Defrosting	Automatic
Temperature Controller	Digital
Horsepower	1/2 HP

#### CONSTRUCTION

Exterior Material	Pre-painted Steel
Interior Material	Pre-painted Steel
Interior Light	L.E.D
Number of Casters/Feet	4 Feet + 4 Casters

### TECHNICAL DRAWING

MODEL: **LDCD-C**

MFR ITEM #:



NEMA 5-15P

SIDE VIEW

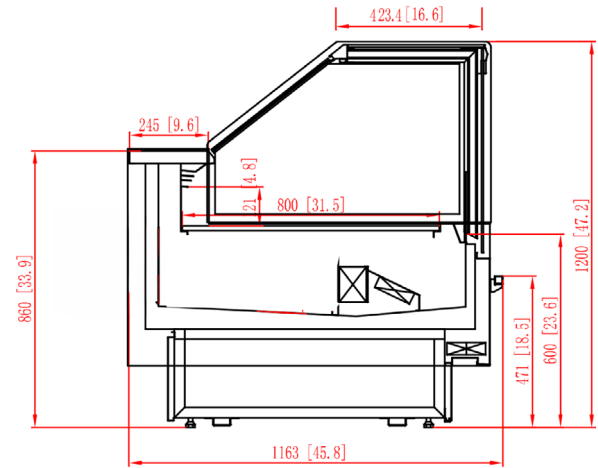

TOP VIEW

