

Project:	Quantity:
Model #:	Approval:

For Commercial Use Only

### CHOCO10R 2.6 Gallon 10 Liter Red Hot Beverage / Hot Topping Dispenser



#### STANDARD FEATURES

- Easy to operate with digital controller
- Strong non-stick mixing paddle
- 2.6 Gallon / 10 liter capacity
- Electronic heating system
- Thermal protector

Increase hot chocolate sales this winter with the CHOCO10R, 10 liters (2.6 Gallon) heated hot chocolate dispenser capable of dispensing 210 cups per hour. Also great for hot cider, mulled wine, and even hot water, this versatile unit can hold up to 90°C. The food grade high-density polycarbonate bowl will display your product in crystal clear clarity while a built-in agitation mixer keeps your product and flavor consistently smooth.

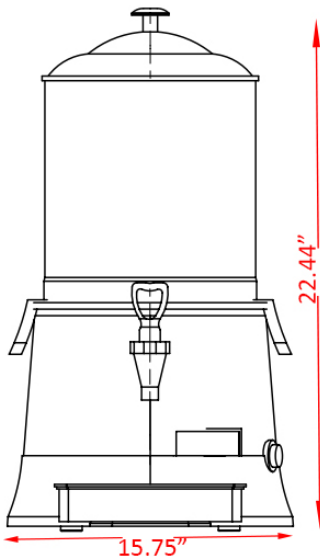

#### TECHNICAL DATA

Model (MFR ITEM#)	CHOCO10R (CH10L)
Exterior Dimension	15.75" x 12.6" x 22.4"
Packing Dimension	16.53" x 14.17" x 23.63"
Net Weight/Gross Weight	15.44 lb./22.05lb.
Voltage/Hertz/Phase	120V/60Hz/1PH
Wattage	400W
Motor Power	40W
Temperature Range	30 to 90 ° C
Heating System	Electronic
Body Material	Stainless Steel

USR Brands is a US supplier of premium quality commercial cooking, refrigeration and food preparation equipment. Our aim is simple. Produce industry-leading commercial restaurant equipment at reasonable prices, and back it all up with an easy to understand, no nonsense warranty that people can count on.