

Project:	Quantity:
Model #:	Approval:

*For Commercial Use Only*

### Coldline B375-30 375 lb. Ice Storage Bin - BIN ONLY



#### FEATURES

- Ice machine storage bin
- 375 lb. ice storage capacity
- Stainless steel and plastic molding construction
- Corrosion resistant
- Polyurethane insulation
- Bin interior is sanitary and easy to clean
- Spring loaded door for easy opening and closing
- 6" adjustable feet
- Hose for water connection and drain pipe included
- Ice scoop included
- Fits Coldline Models: ICE-Y550T-HA

• cETLus Listed  
• ETL Sanitation Listed  
Conforms to UL & NSF Standards



USR Brands is a US supplier of premium quality commercial cooking, refrigeration and food preparation equipment. Our aim is simple. Produce industry-leading commercial restaurant equipment at reasonable prices, and back it all up with an easy to understand, no nonsense warranty that people can count on.

Project:	Quantity:
Model #:	Approval:

For Commercial Use Only

### TECHNICAL DATA

#### DIMENSIONS

Exterior Dimensions	30.7"W x 32.56"D x 38.78"H
Packaging Dimensions	34.1"W x 35.43"D x 42"H
Unit Weight	88 lb.
Shipping Weight	95 lb.

#### BIN

Bin Storage Capacity	375 lb.
----------------------	---------

#### CONSTRUCTION

Exterior Material	Stainless Steel
Interior Material	Polyethylene
Insulation Material	Foamed-in-Place Polyurethane
Legs / Feet	Adjustable / Leveling
Accessories Included	Ice Scooper Water Hose Drain Hose

### TECHNICAL DRAWING

MODEL: **B375-30**

MFR MODEL: BIN-550

#### BACK VIEW

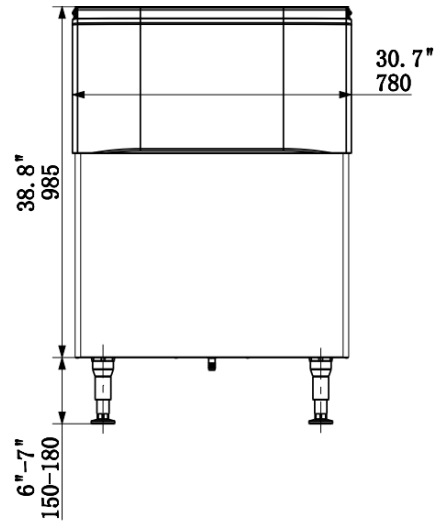

#### SIDE VIEW

