

PROJECT:	
MODEL # :	
ITEM # :	QTY :
AVAILABLE W/H :	APPROVAL :

Meat Grinder



BMG480

STANDARD FEATURES

CONFORMS TO ALL SAFETY REGULATIONS

- Gear Powered Screw Motor (1Hp Heavy Duty Motor)
This provides you with the essential function to grind meat at a swift pace without crushing or mashing the product.
- Other Important Benefits
Bull Grinder provides superior performance to handle most tough meat and food grinding jobs.
This heavy-duty machine grinds 9 to 14 lbs per minute.
- The Reverse Switch
This special feature is intended to maximize productivity by reducing operator fatigue and discomfort.
- High Quality Stainless Steel Surfaces
Meat product will only contact the high quality stainless steel surfaces to ensure cleanliness as well as safety.
- Easily Removed and Cleaned
The bowl assembly and feeding tray can be easily removed and cleaned without the inconvenience of using tools.
- Safety Opening Function
The stainless steel bowl assembly also includes a safety opening function to decrease the possibility of injuries to the user.

WARRANTY

1 Years Parts and Labor

APPROVALS:

AVAILABLE AT:

Meat Grinder

PRODUCT PLAN VIEW

- Top View -

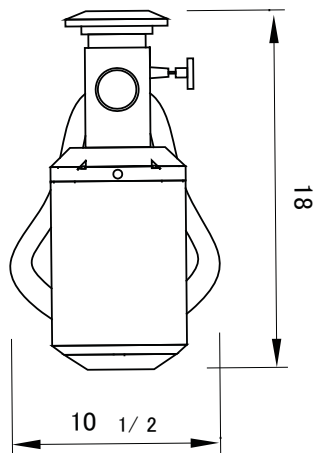

- Front View -

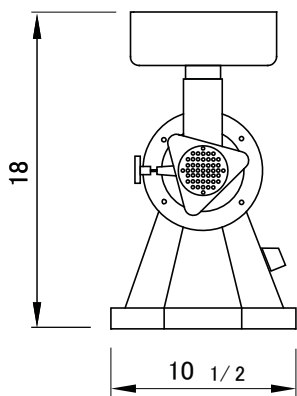

- Side View -

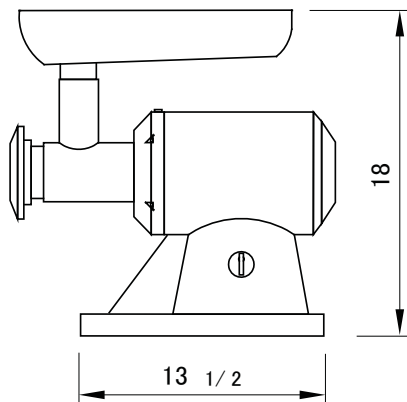

- Rear View -

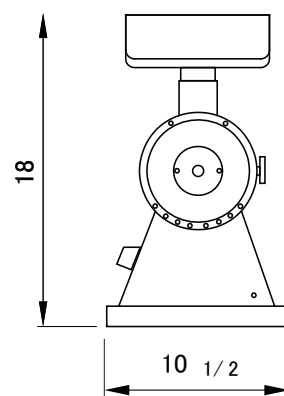

PRODUCT SPECIFICATION

Meat Grinder

Model	Exterior Dimensions (inches)			Max Grinding Capacity (lbs/Min)	Input	Motor Power	Net Weight (lbs)
	Length	Depth	Height				
BMG480	10 1/2"	18"	18"	9 to 14	AC110~120V/60Hz	1HP(735W)	51

*BLUE AIR has the right to change specifications without further notice.