





BLUELAA

FRYER FOUR TUBE BURNER BLF4-LPG / BLF4-NG 6 gallon / 50lbs

PRODUCT DESCRIPTION

 Expanded "Hot Zone", due to 4 super efficient cast iron tube burners in each Fryer. Even heat distribution and quick recovery. Oil temperature fluctuations are regulated by a heavy-duty probe that activates a climate assist burner for reliable and even heat consistency.

 Millivolt safety control system regulates temperatures for BLF4-LPG/NG. Temp range of control is 200 - 400 degrees Fahrenheit.

 ALL areas of the internal frypot can be reached and cleaned by hand. No "out of reach" zones.

 Oversized cold zone and gently pitched frypot floor promote particle and sediment collection toward the front of the Fryer for easy removal and cleaning. Larger Cold zone and localized sediment collection allows for cleaner and longer lasting oil usage.



Oil Tank

Fryer Burner

Fryer Baskets

FRYER MODEL	DIMENSION		
	Width	Depth	Height
BLF4-NG	15 1/2in	32 7/8in	45in
BLF4-LPG	15 1/2in	32 7/8in	45in

* All measures are presented in Inches



223 W. Rosecrans Ave. Gardena, CA 90248
T: 310.808.0102
F: 310.808.0242

9 W. Shelton Terrace #A Hillside, NJ 07025
T: 908.688.0970
F: 908.688.8143

DETAILS & SPECIFICATIONS

FRYER FOUR TUBE BURNER BLF4-LPG / BLF4-NG

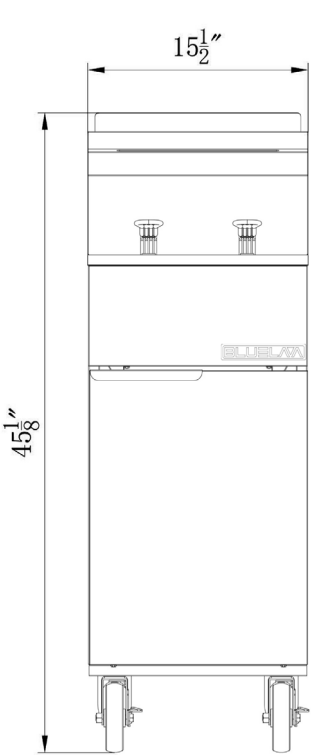

Front View

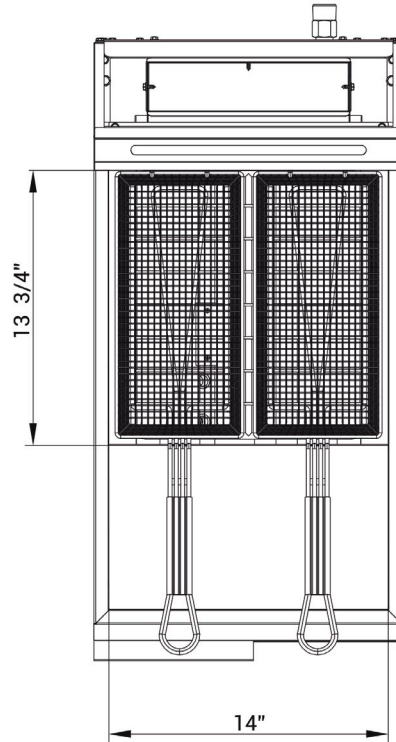

Top View

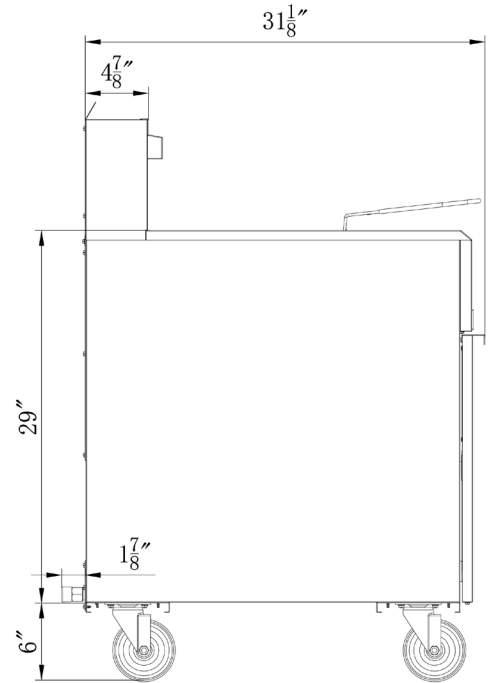

Side View

BLF4--LPG

GAS SOURCE	LPG
WORK AREA	14.01x13.98in
BURNER	4 count
SINGLE BURNER	30000 BTU/H
COMBINED	120000 BTU/H
OIL TANK CAPACITY	6 gallon / 50lbs
GAS PRESSURE	10 "WC
NOZZEL	52#
CONTAINER FITMENT	130

BLF4-NG

GAS SOURCE	NG
WORK AREA	14.01x13.98in
BURNER	4 count
SINGLE BURNER	30000 BTU/H
COMBINED	120000 BTU/H
OIL TANK CAPACITY	6 gallon / 50lbs
GAS PRESSURE	4 "WC
NOZZEL	39#
CONTAINER FITMENT	130

Model	Packaging Dimensions (inches)			Net Weight (lbs)	Ship Weight (lbs)
	W	D	H		
BLF4-LPG	17 7/8"	35 3/8"	37 5/8"	176.37	198.42
BLF4-NG	17 7/8"	35 3/8"	37 5/8"	176.37	198.42

