

PROJECT:	
MODEL #:	
ITEM #:	QTY:
AVAILABLE W/H:	APPROVAL:

Glass Door Merchandiser Freezer



BKG23-HC

BKG49-HC

BKG72-HC

STANDARD FEATURES

Cabinet construction

- Black or white painted steel exterior and white painted steel interior.
- High density foamed in place polyurethane insulation – Environmentally safe.
- Sturdy, epoxy coated wire shelves with adjustable shelving height.
- 4 shelves for each compartment
- 2.5" Diameter swivel casters with front brakes. Four casters on one- and two-door models and six on three-door models (two casters on each model have front brakes)

Refrigeration

- Hydrocarbon refrigerants (R-290) – increases energy efficiency by up to 25% compared to using HFC refrigerants. It is safer for the environment and does not cause ozone depletion.
- Front sliding refrigeration unit allows the unit to be serviced without being moved.
- Self-contained system, bottom mounted compressor provides quick and easy maintenance

- Epoxy coated evaporator reduces potential corrosion.
- Freezer has a temperature range between -10 and 0°F

Doors

- Self closing doors (doors close at 90° or less)
- Automatic hold open door feature at 110°
- Durable door gasket with easy replacement.
- Heavy duty recess door handles
- Door designed to open easily. Doors built with pressure relievers to eliminate vacuum pressure and allow easy door opening.
- Standard door locks
- Triple pane glass

Design & Features

- Digital temperature control & monitor system Keep food products safe by maintaining constant temperatures.
- Digital display allows for easy monitoring.

- Programs interpret the condition of refrigeration systems by self-diagnosis.
- Controls include automatic evaporator fan motor delays.

Lighting

- LED backlit graphic panel
- Interior Vertical LED lighting

Standard

- NSF/ANSI Standard 7 compliant

Connection

- 9 ft long flexible three wire cord with molded plug

Optional Features & Accessories

- Additional shelves are available

WARRANTY

2 Years Parts and Labor
5 Years on Compressor in USA

APPROVALS:

AVAILABLE AT:

Glass Door Merchandiser Freezer

PRODUCT PLAN VIEW

- Top View -

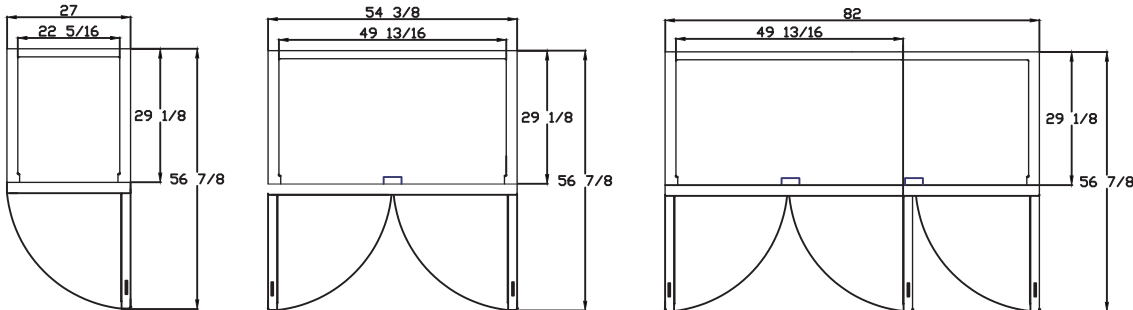

- Front View -

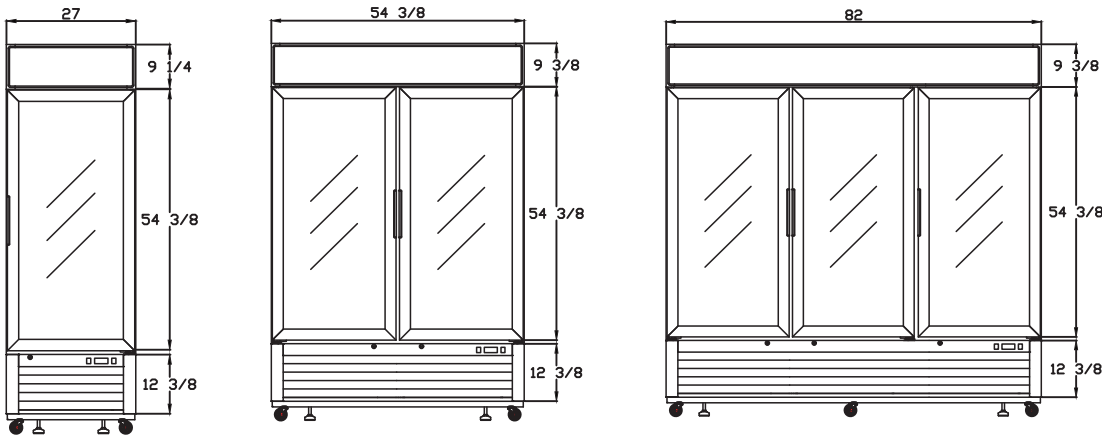

- Side View -

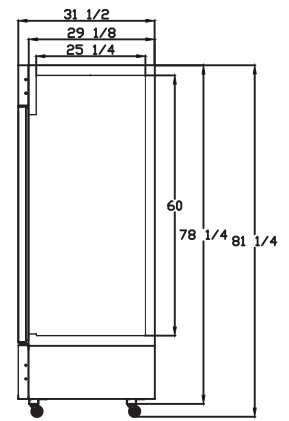

BKGF23-HC

BKGF49-HC

BKGF72-HC

PRODUCT SPECIFICATION

Model	Product Description						Refrigerant				Temperature Range	
	Glass Door Merchandiser Freezer						R-290				-10 and 5°F	
	Easy Maintenance						NEMA Config.				Cord Length (ft/m)	
	Sliding Condensing Unit						NEMA 5-15 (BKGF72-HC: NEMA L14-20)				9.8ft(3m)	
	Doors	Capacity (Cu. Ft.)	Shelves	Cabinet Dimensions (inches / mm)			Casters	HP	Amps	Voltage	Net Weight (lbs/kg)	Ship Weight (lbs/kg)
			L	D	H							
BKGF23-HC	1 Swing	23	4	27"(685mm)	31 1/2" (800mm)	81 1/4" (2065mm)	4	1/2	6.3	115V/60Hz	309(140)	340(154)
BKGF49-HC	2 Swing	49	8	54 3/8"(1382mm)	31 1/2" (800mm)	81 1/4" (2065mm)	4	3/4	8.6	115V/60Hz	498(226)	558(253)
BKGF72-HC	3 Swing	72	12	82"(2079mm)	31 1/2" (800mm)	81 1/4" (2065mm)	6	1	6.2	115V/230V/60Hz	663(301)	768(348)

*BLUE AIR has the right to change specifications without further notice.