



RESOURCES

# UNDERBAR REFRIGERATION



Use your smart phone to scan the above QR code to visit our website: [www.bk-resources.com](http://www.bk-resources.com)

Model:

## GF-50

## Glass Froster / Plate Chiller



### GF-50

#### • Heavy Duty Construction

Top is made of solid 18 gauge stainless steel for easy cleaning.  
Wear resistant black vinyl exterior.  
Galvanized interior with SS floor and coved corners.  
Compressor is mounted on the right side with service friendly slide out rail system.

#### • Enhanced Refrigeration System

Factory engineered oversized and balanced refrigeration system.  
CFC-free R-134a refrigerators maintain temperature below 0°F for the best in chilling glasses.

#### • Digital Thermostat

#### • High Density Polyurethane Insulation

The entire unit has a CFC-free polyurethane insulation foamed in place for extra strength and energy efficiency.

#### • 3 Compartment Levels with Exclusive Sliding Rack System

PRODUCT DATA SHEET

Commercial Use Only - Not warranted for residential use

Specifications subject to change without notice

MODEL	LIDS	SHELVES	AMPS	HP	VOLTAGE	NEMA PLUG	CORD LENGTH	CAPACITY 8 OZ MUGS	CAPACITY 10 OZ MUGS	CABINET DIMENSIONS			SHIPPING	
										L	W*	H	WT.	CUBES
GF-50	2	6	8.5	1/3	115/60/1	5-15P	8'	84	234	49 <sup>5</sup> / <sub>8</sub> "	26 <sup>7</sup> / <sub>8</sub> "	35 <sup>3</sup> / <sub>8</sub> "	269	27.5

\* Does not include 1" bumper

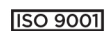

Conforms to UL and NSF-7 standards

RESOURCES





RESOURCES

# UNDERBAR REFRIGERATION

Model:

## GF-50

## Glass Froster / Plate Chiller

### Construction

- 18 gauge stainless steel top and stylish black vinyl finish front, sides and back. Interior built of galvanized steel walls with coved corner stainless steel floor.
- Interior fluorescent light.
- The entire cabinet has a 2" CFC-free, polyurethane insulation foamed-in-place.

### Refrigeration System

- Oversized and balanced refrigeration system.
- Self-contained capillary tube system using environmentally friendly and CFC-free refrigerant. R-134a holding temperature below 0°F for the best in chilling glasses.
- Front breathing/side mount compressor for ease of service and placement in narrow spaces. Condensing unit is behind the front grill, slides out for easy cleaning and maintenance.
- Forced air cooling system for faster cooling and constant temperature in the cabinet.

- Large fan motor and fan blades for better air circulation.
- Self contained system, no plumbing necessary.
- Digital thermostat.

### Standard Extras

- Three compartment levels with exclusive sliding rack system, epoxy coated.

### Electrical

- Each unit is completely pre-wired at factory with cord and plug set included and ready for final connection to a 115/20/1 phase.

### Warranty

Continental USA & Canada

- Two year labor and parts
- Five year compressor
- International: one year parts only

*Commercial Use Only - Not warranted for residential use*

### Options & Accessories

- 3" Casters
- 220v-50Hz-1Phase

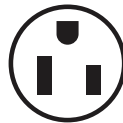

115/20/1  
Nema-5-15P

### Plan View

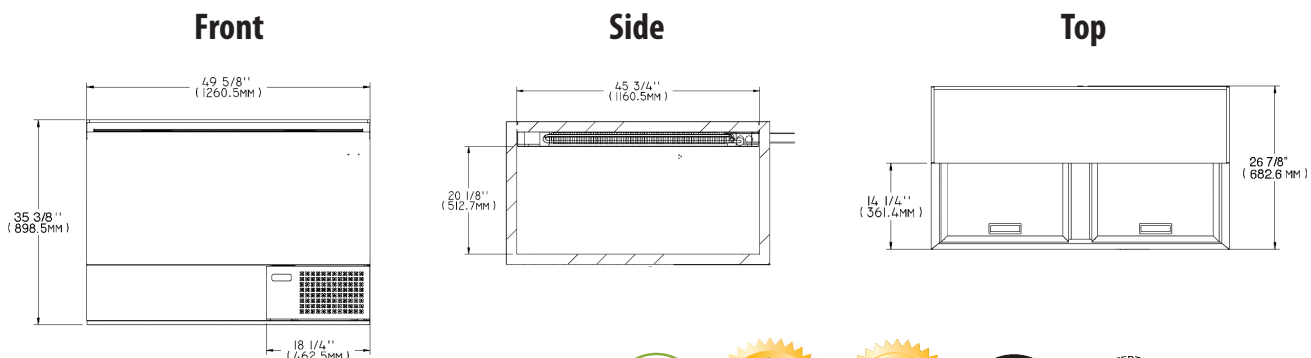

Conforms to UL and NSF-7 standards

