



BEVERAGE-AIR

3779 Champion Blvd., Winston-Salem, NC 27105
1-888-845-9800 Fax# 1-336-245-6453
<http://www.Beverage-Air.com>

CUSTOMER'S CHOICE FOR A HOT KITCHEN
Tested & Certified to Ambient Class of 100°F

Item No. _____
Quantity _____

BOTTOM MOUNTED DUAL-TEMP REACH-IN REFRIGERATOR/FREEZER

Horizon Series
Solid Doors & Glass Doors

MODELS:
HBRF49-1
HBRF49-1G

3 Year Parts/Labor Warranty Additional 2 Year Compressor Warranty

HORIZON DUAL TEMPERATURE REACH-IN

Triple section, DUAL TEMPERATURE reach-in used for storage of refrigerated and frozen product.

CABINET CONSTRUCTION

- Exterior—Stainless steel interior and exterior standard.
- Insulation—foamed-in-place CFC and HCFC-free polyurethane insulation.
- One-piece grille allows easy removal/installation for preventative maintenance.

Anti-microbial door handles are standard.
Doors provide automatic hold-open feature.

SHELVING

Three (3) heavy duty epoxy coated wire shelves per section standard.
Four (4) shelf clips included per shelf (field installed).
Shelves are adjustable in ½" increments.

ELECTRONIC CONTROL

Electronic thermostat with manual defrost (*freezer*) button provides a digital display of cabinet temperatures, which includes status indicators and key pad for any necessary temperature adjustments.

REFRIGERATION

Self-contained bottom mount refrigeration system. Expansion valve refrigerant control on freezer section provides quick temperature pull down and reduces compressor run time—meaning reduced energy consumption. Includes automatic condensate disposal.

Refrigerators utilize ozone friendly R134a refrigerant. Freezer section utilizes ozone friendly R404A refrigerant and its defrost system is fully automatic, time-initiated and temperature terminated operation.

Freezer section product temperatures from -10°F to -15°F.
Refrigerator section product temperatures from 36°F to 38°F.

ELECTRICAL

Interior fluorescent lighting enhances product illumination.

Optional LED lighting on glass door models provides hidden light source for increased product visibility. LED bulbs last up to 10 times longer compared to fluorescent bulbs and renders additional energy savings due to reduced wattage load on compressor.

Refrigerator section wired at factory and ready for connection to a 115/60/1 phase, 15 amp dedicated outlet. Freezer section wired at factory and ready for connection to a 115/60/1 phase, 20 amp dedicated outlet. 8' long cord and plug set included.



HBRF49-1

SPECIAL FEATURES

- Anti-microbial door handles
- Electronic control with digital display
- Glass door models available
- Optional LED lighting
- **Flexible door configurations:** freezer/refrigerator or refrigerator/freezer (see page 2)
- **Available options:** Wine Racks, Chrome Plated Shelves, Black Shelves, Spring Feed Dividers, Audible Alarm, 6" Seismic/Flanged Legs



115/60/1
NEMA-5-15P



115/60/1
NEMA-5-20P
Freezer

ELECTRICAL CONNECTION

Units pre-wired at factory and include 8' long cord and plug set.



*Note: Not all markings may apply to all model variations.

Available From:

Model Specified _____	Store# _____
Location _____	Quantity _____



Bottom Mounted Dual-Temp Reach-In

Model: HBRF49-1, HBRF49-1-G

Note: Other door configurations available. Contact factory.

MODEL	HBRF49-1 HBRF49-1-G
EXTERNAL DIMENSIONAL DATA	
Length Overall (inches)	52"
Length Overall (mm)	1321
Depth Overall (inches) - includes handle	33 3/4"
Depth Overall (mm) - includes handle	857
Height Overall— (inches)	78" / 1981
Height Overall— (mm)	
Number of doors	2
Depth with Door Open 90 °	60"
INTERNAL DIMENSIONAL DATA	
NET Capacity (cubic ft.)	49
NET Capacity (Liters)	1388
Internal Length Overall (inches)	49"
Internal Length Overall (mm)	1245
Internal Depth Overall (inches)	28 1/2"
Internal Depth Overall (mm)	724
Internal Height Overall—(inches)	61 3/4"
Internal Height Overall—(mm)	1569
ELECTRICAL DATA	
Full Load Amperes 115/60/1 (Freezer sections)	10.9 A
Full Load Amperes 115/60/1 (Refrigerator sections)	5.8 A
REFRIGERATION DATA	
Horsepower (Freezer sections)	1/2
Horsepower (Refrigerator sections)	1/3
WEIGHT DATA	
Gross Weight (Crated lbs)	560
Gross Weight (Crated kg)	254

PLAN VIEWS

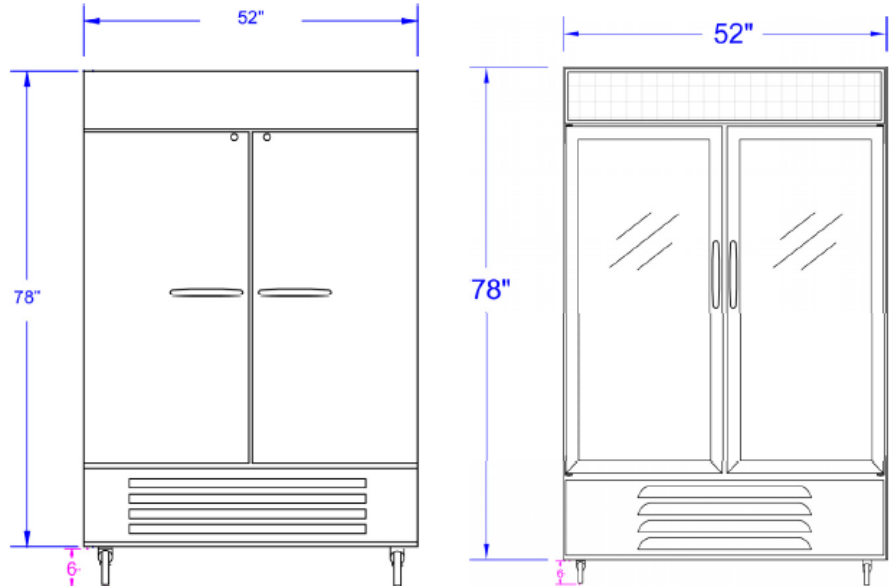

HBRF49-1
FRONT

FRONT
HBRF49-1-G
FRONT

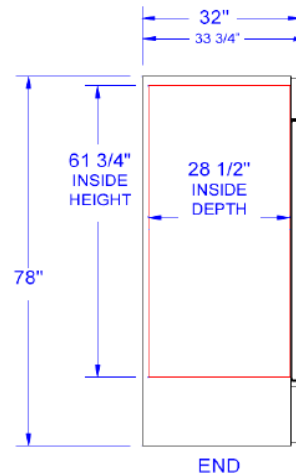

END

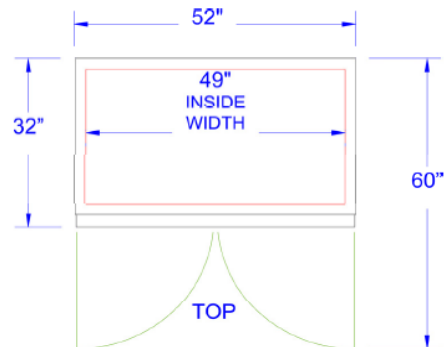

TOP



*Note: Amps & hp subject to change based on door configurations.

*Note: Not all markings may apply to all model variations.

DOOR CONFIGURATIONS (CHOOSE 1)

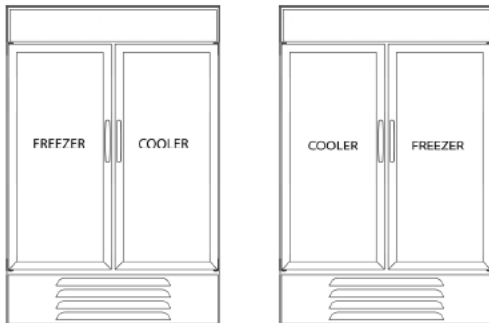

BEVERAGE-AIR® CORPORATION

3779 Champion Blvd. • Winston-Salem, NC 27105 USA • (336) 245-6400 • Fax (336) 245-6453 • (888) 845-9800 • www.beverage-air.com

Specifications are subject to change without prior notice. 08/13